

IRR  
ODI

THE INTERNATIONAL  
REVIEW OF RESEARCH IN  
OPEN AND DISTANCE LEARNING

Vol 15  
No 4

## Editorial – Volume 15, Issue Number 4



Rory McGreal  
Co-Editor, IRRODL

Welcome to the first fall edition of IRRODL. This edition can be divided into two sections; the first is pedagogical and aimed at practitioners. It contains papers researching interaction, focusing on social and collaborative learning, synchronous and asynchronous activities, roleplaying, crowdteaching, grouping, and the effects of learning styles. The second section is aimed at distance education administrators and program directors. It contains papers on management, elearning design, and rating teachers, followed by investigations into student performance in MOOCs and the analysis of data for assessing multiliteracies and student needs.

### **Section 1: Pedagogical papers**

Two papers investigate social networking, one by open educational practitioners and the other by students. The first paper (Schreurs et al.) focuses on the activities of open educational practitioners, describing how their participation is supported in the context of online collaborations. The paper is rather long, but it was felt that the interview quotations were highly relevant and of interest to distance learning professionals. The views of students on their social networking experience in a learning management system is the subject of Özmen and Atici's qualitative research paper. Using semi-structured interviews, the researchers investigate the use of social networking and the students' attitudes towards the experience.

Action research is used by Koechli and Glynn to describe the development of a roleplaying website called Lake Devo as an example of an online role-play environment. The effects of the audio and visual presentations including avatars were the subject of their study, which involved surveying the students and debriefing them at the conclusion of the activities.

Collaborative learning is the focus of three papers. The first by Kear et al. makes use of the technology acceptance model (TAM) to examine and discuss the experiences of students and tutors involved in collaborative groupwork using wikis. The perceptions and needs of both students and tutors are considered. Second, Malinovski et al. use structural equation modeling to analyze high school students' subjective quality experience and expectations during asynchronous and synchronous distance education activities. The third paper by Hwang et al. was a control group/experimental group study. It included an investigation of collaborative learning using the Networking Virtualization-Based Laboratory (NVBLab), which supports online synchronous discussions.

The last two pedagogical oriented papers look at crowdsourcing and learning styles. Recker, Yuan, and Ye investigate the employment of high quality web-based content by teachers as part of a crowdsourcing community. The study examines their usage activities and analyzes their characteristics, concluding that they are engaged in "crowdteaching". In a comparative study, Çakıroğlu examines the relationships among learning styles, study habits, and learning performances in a computer science course.

## **Section 2: Administration papers**

Using Moore's theory of transactional distance and social cognitive theoretical framework, Jowallah evaluates the strategies implemented to support the research activities of postgraduate students in the University of the West Indies Open Campus. This study included the role of teaching/learning spaces, scheduling, and seminars.

Examining multiple articles and texts, Hillen and Landis investigate what kinds of pedagogy, instructional design models, or didactical models are established and proposed for e-learning design in the US and Europe. They study the different educational philosophies, specific theories about learning, and e-learning design.

In their study, Prasad and Usagawa assess the University of the South Pacific teachers' willingness to develop OER textbooks. Research findings include data on teachers' motivation, frequency of more than one prescribed textbook per course, teachers' awareness of costs, the average cost of textbooks, teachers' awareness and use of OER, and teachers' perceived barriers.

Stojić et al. studied the characteristics that affect teacher ratings by students, both at a distance and in traditional classrooms. The parameters considered include the number of teachers in a particular course, the number of courses taught, the teacher's gender and age, and the available resources.

Analyzing pre- and posttests, using item response theory, Colvin et al. studied student learning in an EdX MOOC and a blended learning course. They evaluated various criteria such as the students' level of education, preparation, and overall ability in the course.

The final two papers involve conceptual frameworks using learning analytics. The first, by Dawson and Siemens, posits a framework for measuring individual achievement of multiliteracies using learning analytics. The authors also suggest how this approach can assist in scaling the evaluative process. The last paper in this edition by Prinsloo and Slade proposes harvesting and analyzing student data to inform strategic decisions, including marketing, enrolment, curriculum development, the appointment of staff, and student assessment. They propose using triage, defined as balancing between the impact of the intervention, the scope of care required, and the resources available.

Athabasca University 



## An Investigation into Social Learning Activities by Practitioners in Open Educational Practices



Bieke Schreurs<sup>1</sup>, Antoine Van den Beemt<sup>1</sup>, Fleur Prinsen<sup>1</sup>, Gabi Witthaus<sup>2</sup>, Gráinne Conole<sup>2</sup> and Maarten De Laat<sup>1</sup>

<sup>1</sup>Open Universiteit Nederland, <sup>2</sup>University of Leicester, UK

### Abstract

By investigating how educational practitioners participate in activities around open educational practices (OEP), this paper aims at contributing to an understanding of open practices and how these practitioners learn to use OEP. Our research is guided by the following hypothesis: Different social configurations support a variety of social learning activities. The social configuration of OEPs is investigated by an operationalization into the dimensions (1) practice, (2) domain, (3) collective identity, and (4) organization. The results show how practitioners of six different OEPs learn, while acting and collaborating through a combination of offline and online networks. The findings of our study lead to practical implications on how to support participation in OEP, and thereby stimulate learning in (online) networks of OEP.

**Keywords:** Open educational practices; networked learning; communities of practice

## Introduction

Researchers claim that the success and sustainability of open educational practices (OEP) depend on prospering and fit OEP movements built around full and open collaboration between educational institutions and amongst individual practitioners (Lane, 2008). However, little insight exists into how these groups of practitioners come to live, function, or learn together with colleagues (Fetter, Berlanga, & Sloep, 2011). To improve our understanding of open practices and how practitioners involved in OEP initiatives learn to use OEP, this article investigates how these practitioners participate in a range of activities around OEP such as the creation, adaptation, and reuse of OEP and accreditation of OEP-based learning.

Our work is empirically supported by the findings from six case studies into communities based on OEP. These results contribute to an understanding of how practitioners learn within these six different OEP while acting and collaborating mostly, but not entirely, through online networks. In more detail, we investigate the social configuration of these six OEP and investigate how this social configuration influences the learning of practitioners. The findings of our study lead to practical implications on how to support participation in OEP, and thereby stimulate learning in (online) networks of OEP.

## Theoretical Background

In this article, we perceive lifelong learning as participation-based and situated in shared work practices. On the one hand, this perspective is rooted in the idea of communities of practice (CoPs) (Lave & Wenger, 1991). On the other hand, we discuss how recent organizational developments, such as new ways of working and the use of social media in organizations, could change the organizational landscape, engendering open networks in which practitioners work, learn, and innovate. In this article we focus on the way learning is taking place through participation in such open practices. We are specifically interested in understanding how social participation and collaboration is taking place.

In practice we see many different forms of social collaboration unfold, especially since people come and go based on their changing needs. This group dynamic results in diversity in strength of relationships between participants and thus leads to diversity in presence and engagement in group learning (Dron & Anderson, 2007). To understand the nature of these open practices different typologies of social forms that a collection of learners might participate in have been developed (Dron & Anderson, 2014). In what follows we distinguish between communities, networks, and teams and use these concepts to explore learning embedded in OEPs.

## Communities of Practice

In recent years, we have witnessed an uptake of OEPs in many countries (for a list of more than 124 notable OEP initiatives, please see [http://poerup.referata.com/wiki/Country\\_reports](http://poerup.referata.com/wiki/Country_reports)). Researchers investigating professionals who collaboratively participate in these initiatives often refer to the concept of 'communities of practice' (CoPs): groups of people who share a craft and/or profession (Lave & Wenger, 1991). Participants in a CoP are informally bound by what they do together and by what they have learned through their mutual engagement in these activities (Wenger, 1998). However, it is argued that the informal binding of individuals based on shared interests may be non-committal and may not contribute directly to learning activities (Büchel & Raub, 2002). Commitment can be established when the shared activities of a group are embedded in a historical and social context that gives structure and meaning to these activities.

Based on the work of Wenger (1998), a large number of studies show how professionals organize their lives together with colleagues, peers, and customers in CoPs to get their jobs done. These studies also show how within communities the rules of the working game are set: how to do the job and how to do it more efficiently. If these rules about performing a practice are the core business of a CoP, one might expect however that members of a CoP would be reluctant to change the way things are done in the group, or the practice they work in. Much of the research and practice around CoPs has focused on establishing the core of these communities and developing skills and competencies to participate in them (Admiraal, Lockhorst, & Van der Pol, 2012). While the focus has been on community building efforts, the important notions of Wenger (1998) on boundary crossing and the ability of CoPs to constantly negotiate their practices have been largely ignored.

## Networks of Practice

Today, practitioners increasingly realize that opportunities for growth, development, and innovation lie outside their own organization. These and recent other technological developments have given rise to more openness in organizational practices. This openness makes employees less constrained by boundaries that otherwise would impede knowledge sharing. Current technologies and use of social media for example enable professionals to connect with their peers with greater ease, at a larger scale and on a continuing basis (De Laat, Schreurs, & Nijland, 2014). By emphasizing for instance relationships and flows of information, networks of practice are distinguished from CoPs (Wenger, Trayner, & De Laat, 2011; Brown & Duguid, 2001). Others define networks of practice as 'nets', resulting from individual connections between people, with no explicit hierarchies or membership (Dron & Anderson, 2014).

Bottrup (2006) speaks of the potential of network-based learning as an important complement to workplace learning and formal learning. She claims that networks could be a special arena for learning because they give professionals the potential to take a

needed step away from their daily work practice to reflect and search for new perspectives amongst peers. At the same time network members share goals, which could make it easier to translate shared knowledge to their own working environment.

Open networks of practice are "collections of individuals who come together across organizational, spatial and disciplinary boundaries to create and share a body of knowledge" (Pugh & Prusak, 2013). These networks have shifting and distinct boundaries (Dron & Anderson, 2014). The focus of such networks is usually on developing, distributing, and applying knowledge and, to some extent, on building a collective identity as is seen in communities. Organizations of all sizes are seizing this model to learn more quickly and collaborate productively (Pugh & Prusak, 2013).

## Teams

Alongside communities and networks, 'teams' can be found: 'groups of people that work together cohesively toward a common goal' (Dechant, Marsick, & Kasl, 1993, p. 1), where members 'have been assigned specific roles or functions to perform' (Salas, Dickinson, Converse, & Tannenbaum, 1992). This description resembles Dron and Anderson's (2014) definition of 'groups': externally regulated entities, with clear goals, attributes, and rules. Team learning is defined by tasks rather than knowledge and often guided by institutional schedules and limitations in authorized groups. In contrast, a community's life cycle is determined by tacit knowledge sharing in informal groups based on self-organization and volunteered participation with boundaries beyond the organization (Knapp, 2010). A community can be located somewhere between teams and networks as a form of social organization (Wenger, Trayner, & De Laat, 2011).

## Learning in Social Configurations

Our perspective on learning follows Boud and Hager (2012). They emphasize learning as a continuous process driven by needs that emerge in daily practice, by using terms such as organic growth, evolution, and gradual unfolding. Learning is a process of participation in practice, where professionals continuously develop their identity and abilities in response to events in their professional environment. Boud and Hager thus place learning in a social context, where professionals work and learn together, change and innovate both their professional practice as well as who they are. This perspective on learning involves being in touch with professional colleagues, building the networked connections needed to participate in constructive professional dialogues about what it means to become a professional, and being able to perform in the workplace (Lohman, 2006). Learning in a social context requires facilitation (Büchel & Raub, 2002) and a safe supporting environment (Dron & Anderson, 2014). To implement OEPs, developing, sharing, and applying knowledge are of undeniable importance (Lane, 2008). However, how do practitioners learn from each other while involved in OEPs? Do OEPs encourage the emergence of more or less 'pure' communities, networks, or teams? Can we distinguish different social configurations and, if so, how does the social configuration influence the way practitioners learn from each other to implement OEPs?



We argue that these social configurations within OEPs can influence the learning activities.

Although the complexity of social learning has been acknowledged and theoretically explained little is done to help identify this in practice. Most of this work is done from a single theoretical construct, be it community, networks, or teams. For example, Galley, Conole, and Alevizou (2012) develop community indicators to observe and support online communities. Admiraal, Lockhorst, and van der Pol (2012) developed a community support framework to help develop teacher communities.

But in practice, social learning is a palette of colors that blends in different ways (Dron & Anderson, 2014). The study of the complexity of social learning cannot be restricted to a strict theoretical typology (Wenger, Trayner, & De Laat, 2011). Therefore Vrieling, Van den Beemt, and De Laat (in press) developed a framework that perceives the characteristics of communities, networks of practice, and teams as integral aspects of social learning.

## Dimensions of Social Configuration

The framework of Vrieling, Van den Beemt, and De Laat (in press) operationalizes the social configuration of OEPs into four dimensions: (1) practice, (2) domain, (3) collective identity, and (4) organization. Each of the four dimensions is constructed from several indicators, which reflect leading themes in literature on social learning. These indicators are measured as the extent to which the group shows specific attitudes and behaviour. The dimension *practice* refers to the extent to which the group knowledge is integrated into day-to-day activities and the extent to which the group shows continuous rather than temporary activities. *Domain* refers to the shared area that inspires the participants to share, broaden, or deepen their knowledge and skills within the group. This sharing can lead to value creation on the individual, community, and society levels, provided the group has a clear purpose and goals (see also Büchel & Raub, 2002). *Collective identity* measures the mutual engagement that binds the members together in a social entity, shown for instance by strong ties and the perception of group members as knowledge workers. This mutual engagement goes together with feelings of openness and trust among the participants (Van den Beemt, Ketelaar, Diepstraten, & De Laat, 2014). *Organization* refers to the extent to which the group members have a shared interactional repertoire, a focus on local or global activities, and equal or hierarchical power relations. Furthermore indicators in this dimension refer to the extent to which the group is self-organized and has influence over its own goals, tasks, and methods (Bottrup, 2006), rather than being directed by management. This indicator should not be confused with management support, which is considered an important organizing premise for successful group learning (Büchel & Raub, 2002).

In order to complete the framework guiding our investigation, we included questions referring to the indicators 'sustainability' and 'creative ability' based on the framework

of Galley, et al. (2012). Galley and colleagues (2012) see persistence of activity as a crude indicator of successful social learning. In their view, a group is successful when the activity continues until the problem is solved. Another important factor according to the authors is creative ability. Creative ability refers to the competences needed to create shared artefacts, shared knowledge, and understanding. This could be particularly important in networks of practice, where people cross institutional borders and work with relative strangers (Galley, et al., 2012). We believe that with this framework we are able to describe a diversity of social configurations.

## Main Hypothesis

We argue that the dimensions of domain, practice, collective identity, and organization can add to an understanding of the functionality of social learning in the field of OEPs. Starting from these dimensions, our main hypothesis is that different social configurations support a variety of social learning activities. We provide preliminary evidence for this hypothesis with reference to empirical data from the six case studies on OEPs.

## Methodology

### Sampling

From an inventory of 124 OEP initiatives worldwide, compiled by the POERUP project (<http://www.poerup.info/>), six case studies were selected. The case studies are defined as notable OEP initiatives. OEP was defined as a set of activities and support around the creation, use, and repurposing of open educational resources (OERs) and MOOCs.

Selection criteria for the cases were: inclusion of primary, secondary, higher education, and vocational training, both long-standing and new initiatives, easy access to respondents through partner contacts, and both national and international initiatives.

### Selected Cases

1. **Digischool**, a national initiative in the Netherlands, started by two teachers in 1995 and resulted in a collection of virtual schools where primary and secondary teachers can share open learning materials and discuss the use of open learning materials in virtual communities. Seventy teachers manage the virtual communities. (<http://www.digischool.nl/>)

2. **UvAMOOC**: The first MOOC (massive open online course) in the Netherlands, titled “Introduction to Communication Science” is an initiative of the University of Amsterdam’s College of Communication and the Graduate School of Communication

Science. It has been run since 2013. The target group consists of college students and lifelong learners all over the world. (<http://mooc.uva.nl/portal>)

3. The **OERu** (OER universitas) is an international initiative of the Open Educational Resource Foundation, based in New Zealand, set up in 2011, with the aim of widening participation in higher education by accrediting OER-based learning. The OERu is a consortium of over 30 public post-secondary institutions. Alongside the consortium, the OERu is enhanced by a system of volunteers (Mackintosh, McGreal, & Taylor, 2011). (<http://oeru.org/> and <http://wikieducator.org/OERu/Home>)

4. The Canadian initiative **BCcampus**, established in 2002 by the provincial government of British Columbia, is a publicly funded organization that aims to bring people from British Columbia's post-secondary system together and make higher education available to everyone by collaborative information technology services. Within this study, we investigated the open education subgroup of the BCcampus project. (<http://bccampus.ca/>)

5. **FutureLearn** is a private company fully owned by the UK Open University (FutureLearn, 2013). It has collaborated with over 20 leading UK and a few non-UK universities and cultural institutions to form the FutureLearn consortium. Since October 2013, the consortium has offered a range of MOOCs at university level

6. **Re:Source** is an initiative of the Scottish Further Education Unit aimed at developing OER for Scotland's colleges. The initial development work took place during 2012 and it is currently managed by the (Scotland) College Development Network. (<http://resource.blogs.scotcol.ac.uk/>)

## Data Collection Method

For each case study, three in-depth structured interviews were conducted, resulting in 18 interviews. Interviews were held with an academic contributor representing an institutional partner, a coordinator or manager, and a person responsible for the technical support or a volunteer. This selection was aimed at including both support staff and academic staff and peripheral participants. The interview scheme was guided by the four superordinate dimensions: (1) domain, (2) practice, (3) collective identity, and (4) organization (Vrieling, Van den Beemt, & De Laat, in press). For the OEP context, we adapted the framework by combining it with the community indicator framework consisting of the dimensions participation, cohesion, identity, and creative capability (Galley, Conole, & Alevizou, 2012). The community indicator framework enabled us to include questions regarding facilities, support, and sustainability. The resulting framework was used to investigate and understand the social configuration of the networks the practitioners are engaged in.

Table 1

*Dimensions and their Indicators of Social Learning*

<i>1. Practice</i>
1a. To what extent does the group exhibit integrated or non-integrated group activities in daily work?
1b. To what extent does the group exhibit temporarily or permanent social activities?
<i>2. Domain</i>
2a. To what extent does the group focus on sharing or broadening/deepening knowledge and skills?
2b. To what extent does the group experience value creation, individually or collectively?
<i>3. Collective identity:</i>
3a. To what extent do participants exhibit a shared or unshared identity?
3b. To what extent does the group exhibit weak or strong ties?
3c. To what extent do the participants view one another as task executors or knowledge workers?
<i>4. Organization:</i>
4a. To what extent does the group operate externally directed or self-organized?
4b. To what extent does the group exhibit 'local' or 'global' activities?
4c. To what extent does the group exhibit hierarchic or equal relationships?
4d. To what extent does the group exhibit shared or non-shared interactional norms?
<i>5. Facilities, support and sustainability</i>
5.a What are the main communication technologies that you use for the activities you undertake as a community? (e.g., VLE, wiki, emails, Skype, etc.) Are these technologies easily available to you? If not, please can you describe the key barriers or obstacles.
5.b How do you rate the usability of the systems that <your community name> employs? (e.g., All systems usable, with internal evidence to back this up).
5.c How would you describe the levels of knowledge or skills demonstrated by the community members in the discussions, debates, and the collaborative productions?
5.d Is there nearby, fast response technical support available for the activities you undertake as a community?
5.e How do you perceive the sustainability of the community you are participating in (in terms of durability, ongoing costs, etc).

## Data Analysis

All interviews were conducted in-person, in some cases via Skype, audio recorded, and lasted on average 45 minutes. The interviews were analysed using a coding scheme developed to generate insights within the four superordinate dimensions. Strategies for monitoring and improving intercoder agreement were used in the analytic process to maintain rigor.

The data analysis consisted of a within-case analysis to reach data reduction, followed by a cross-case analysis to search for patterns in the respondents' answers. In the first phase, data of each respondent were analysed. After coding of the interviews, a thematic coding around categories corresponding to the research question was performed.

Finally, a comparative analysis of all respondents took place, which resulted in accounts to draw conclusions and verify the data with the theoretical concepts related to our research question.

The technique of 'constant comparative analysis' (Glaser & Strauss, 2009) was used for both the vertical and the horizontal analysis in order to continuously compare preliminary interpretations with accounts of the other respondents and the theoretical framework.

## Results

In what follows, we present how the four dimensions domain, practice, collective identity, and organization constitute the social configurations. Results are illustrated with data from the interviews. Subsequently we explore how the social configuration influences social learning activities.

### A) Shared Domain

In all OEPs, educational staff showed dedication to, and could familiarize themselves with, a shared domain: to create and conduct OEPs. In some cases respondents felt they were partly responsible for developing or contributing to this shared domain, whereas in other cases it appeared they were rather 'executing' within a given shared domain. In this respect, the practices of some case studies can be labelled instrumental, such as FutureLearn, Digischool, and UvAMOOC, as they focus on producing OEP. Other case studies, such as OERu, BCcampus, and Re:Source, were found to be more support-driven in their effort to create awareness about OEPs and enable partner institutions to produce and use OER and carry out OEPs.

All initiatives focus to some extent on creating a technological platform for sharing materials. Most initiatives use openly available media in combination with other platforms (e.g., Moodle). For example, within BCcampus the approach is to build on current uses of technology in order to include more people: "We try to be flexible and use what they feel comfortable with. We might set up a website or a wiki if we feel the people in the project feel comfortable with [that]."

Evaluation of OEPs was done in some form in all examined cases; in one case, this was done in an interactive fashion (quality tagging), and in another this was done through implementation of a centralized procedure (course evaluation). While in the OERu quality control has been part of their practices from the beginning, other initiatives struggle to get quality control in place.

Within the shared domain found in all case studies, each case has its own specific purpose. For example, OERu has the purpose of accreditation of OER-based learning, while BCcampus consists of many different working groups with topics ranging from

open textbooks to educational technology support. The purpose of the UvAMOOC is to experiment with MOOCs as a form of teaching, and building up expertise around the use of instructional and technological design. The Re:Source case study focuses on sharing resources amongst different institutions to avoid duplication of materials, which involves a process of collaboration between several institutions.

All examined initiatives were set up to stimulate or exploit the use of technology within education in general, and the experiences and expertise gained within the projects are used to set political agendas. Therefore, they play an important role at the national policy level by pushing the political agenda of their region or country. In order to do so most but not all initiatives have close relations with national or regional policy advisors or ministries of education.

## B) Shared Practice

The dimension shared practice is represented by the extent to which the group exhibits activities integrated in their daily work and the extent to which these activities are continuous.

OEPs that can be characterized by a support-driven approach, with a focus on creating and sharing knowledge, show a profound shared practice. For example the open textbook initiative as part of BCcampus saw librarians from different institutions working together on knowledge about open textbooks, copyright issues, and sustainability of educational materials. Other initiatives with a focus on creating and sharing materials, characterized as the instrumental approach, show a less profound shared practice. The case of Digischool consists of specific topic related subgroups within the larger network, yet the actual production of OEP happens on an individual or institutional basis; the same holds for FutureLearn. All cases reported a large amount of experience and expertise within the OEPs. The extent to which shared practice consists of permanent social activities, even beyond the boundaries of institution or domain, appears to be related to the age of the group. For example the ETUG community, part of the BCcampus initiative, knows a history of over 20 years and shows a strong core group of people meeting each other both inside and outside community gatherings.

OERu respondents, being geographically dispersed around the globe, reported that a shared experience takes time to develop and, at this stage in the OERu's history, the concept of shared practice is more evident in the member institutions, where colleagues have a longer shared history, than in the network as a whole. This aspect differentiates the dimensions practice and domain; because in this case the domain is shared on network level and shared practice is mostly located in the subgroups.

For most case studies shared practice happens both online and offline. Online participation is reported to be facilitated by a wide range of available communication and social media tools, such as wikis, forums, mailing lists, and a number of purpose built platforms. These tools are used in diverse ways, from short periods of browsing to

engagement that is more reflective. OEPs with a focus on the production of open educational resources or MOOCs rather than collaborative production of knowledge reported using fewer tools and mainly wiki-type or online learning environment-type applications. All technologies are reported to be easily available to participants, provided they have Internet access. Regarding usability and technology support, the interview respondents stated that most tools were easy to use. Whenever problems arose, most groups relied on their institutions with helpdesk or in-house technicians.

### C) Collective Identity

The dimension identity is composed of indicators related to the extent to which the network shows strong ties, a shared experience and identity, and members are able to articulate relationships with others that involve a distribution of functions or roles.

A strong shared identity, related to the domain and goal of the community, can be found in the OERu initiative. The shared identity refers to the philanthropic values and purpose of widening access to education using OEP. All OERu participants reported feeling that they belonged to the network and had a sense of ownership.

Within BCcampus and Re:Source there is no evidence of a shared identity on the network level. Yet, subgroups within the networks with an extensive history, sometimes extending long before the beginnings of the initiative, were reported to have a more profound shared identity. BCcampus, for example, counts on existing communities of practice to drive the learning that is necessary for use: “When we started, long before the start of BCcampus, everyone had a purpose coming from their own institutions; as time went on we developed stronger connections to the ETUG-community.”

Respondents all reported their networks as being open, trusting, and collaborative. Participants saw each other as equals, although the case studies show that instrumental networks such as UvaMOOC and Digischool consist of a core group of technical and coordinating staff, showing a co-creating relationship, and a large group of (mostly) non-sharing consumers. UvAMOOC participants shared the feeling that they were collaborating in an interesting experiment in the first massive open online course. The feeling of having a shared identity differs strongly per case study, along the lines of the dimensions domain and practice: Case studies that are support driven showed a stronger collective identity compared to the more instrumental cases.

### D) Organization

All examined OEPs are complex organizations comprising diverse forms of networks, (older) communities and smaller teams. All are (inter)national initiatives, with support from regional or national politics, except for UvAMOOC, where all participating members were located in one institution. Despite the national or regional origin of the case studies, the institutional teams and communities often deal with local issues: specific aspects of education or particular applications of technology. This is true even in



cases where global issues are at the heart of initiatives, such as OERu and BCcampus, where improving access to education is central, since each of the partner institutions also has its own local needs and audience to address.

Coordinators and staff members often state that they do not have enough time or resources to give the OEPs the attention required. The longer-standing networks have a more defined organization compared to newer networks. Networks focused on creating and sharing new knowledge have a collaborative atmosphere, often extending beyond the community itself.

ETUG (BCcampus) is a social bunch that get together for instance to make music. This strengthens the community. During informal meetings, experiences are shared. There is a lot of work virtually, so the face to face events add to the community feeling and shared history.

Because of what was described as a less active audience, instrumental cases such as Digischool are often experienced as only partly collaborative.

There is not much co-creation [in Digischool]. You can show that you have made it together with someone, but in my experience, this does not happen much. ... When it's made, it is made. Maybe people are open to more co-creation, but it doesn't happen (yet).

Most of the cases featured a central actor that either set things in motion or kept the energy in the community high (e.g., by active recruitment of contributors or active inviting of contributions). Within OERu respondents doubted the sustainability of the network without their central *figure* “[who] does a brilliant job of keeping people in the loop, of engaging with new partners, of getting contacts together”, and worried that “without a central unit, institutions could wander off in various directions”. On the other hand, the OERu coordinator himself claimed, “There are natural leaders who emerge [within the partner institutions] and that’s who we work with” (interviews with OERu respondents cited in Witthaus, 2013a, b, and c).

Both contributions by media creators (technicians) and content creators (teachers or other) were key for the activity level of the community. The importance of a central actor specifically holds for initiatives focused on sharing and creating knowledge. In terms of interactional repertoire, all OEPs showed a mixture of types of communication and behaviour, while communities centered on resource use showed more unidirectional interactions.



## Learning as a Result of the Social Configuration

Our results show mixed forms of social configurations within the OEP case studies, providing further evidence that team, community, and network aspects are all part of the social structure of a given group (Wenger, Trayner, & De Laat, 2011; Doornbos & De Laat, 2012; Schreurs, et al., 2014). Most OEPs involve complex organizations with a diversity of networks, communities, and smaller teams. The results second our hypothesis that different social configurations support a variety of social learning activities (Vrieling, Van den Beemt, & De Laat, in press), such as co-creation, sharing knowledge, or sustaining networks of relevant others. This result correlates with Dron and Anderson's (2014) finding that few of the categories are absolute in any given group of people.

The teams are situated within individual institutions and focus mostly on a shared practice: Both learning about the production of OEPs and their creation happens mostly within the teams. Despite the fact that team members 'have been assigned specific roles or functions to perform' and are more hierarchically organized in our case studies, they do have a shared identity (Salas, Dickinson, Converse, & Tannenbaum, 1992), which resonates with items in the community indicator framework (Galley, et al., 2012). Within institutional teams, we see that members are participating in open networks of practice going beyond the borders of their institutions. We distinguished two types of open networks of practice. Within the support-driven networks practitioners cross their institutional boundaries to search for and share knowledge and expertise about the use of OEPs. The support-driven OEPs report more symbolic learning outcomes (Van den Beemt, Ketelaar, Diepstraten, & De Laat, 2014), such as mutual understanding, value in work, and inspiration. For example, within OERu, the shared identity leads to powerful social learning:

Oh this is the most rewarding experience of my entire career. It's a return to the core values of education and to share knowledge freely. At the heart of every educator is this passion to share knowledge; it's [given me] the ability to share this passion. (cited in Witthaus, 2013a)

The instrumental cases were often still looking for shared values, such as in the case of Re:Source: "people are going to have to be exposed to the benefits of sharing, the idea that there is more to be gained by sharing than there is to lose."

When participants of the instrumental cases identified problems related to the intensity with which members participated or noted that participation of certain members was not sustained, this seemed to be at least partly related to a lack of shared identity, where values of the OEP were not (yet) in line with the concerns of other constituting members. Sometimes the innovative drive of the core group and intrinsic motivation found in many other participants was not or could not be shared by all network members.

Learning that happened within the long-lasting communities seemed the most profound. Members of a community are informally bound by what they do together and by what they have learned through their mutual engagement in these activities (Wenger, 1998). Participants in our case studies reported a strong identity around a common agenda or area for learning. In this way, shared learning and interest of the members, together with a shared social and historical context, keep the community together (Galley, et al., 2012).

There is a lot of work virtually [in BCcampus], so the face to face events add to the community feeling and shared history...[also] for the Open Textbook Initiative, we are beginning to see this. So, we organize a book sprint, an intense event that leads in 4 days to a textbook. This should lead to shared ownership.

We see not only different social learning activities, but also different technologies used within the different social configurations. Within the support-driven networks of open practices, people use mostly one-to-one e-mails or group mailing lists to learn from each other. Within the instrumental networks participants often use shared content management systems to publish their OEPs, but use these individually. The community type networks use a wide range of social media to stay up-to-date with each other and e-mail is used to leverage the expertise of community members, in addition to regular face-to-face meetings.

The findings of the different learning activities within the different social configurations are well demonstrated within the OERu interviews with the coordinator and an institutional member: The institutional member reported reading the discussions that come in through the institutional members' mailing list. He reflects on what is being said, contributes his own ideas via the mailing list, and implements the ideas within his own institution by discussing the ideas with colleagues. Within institutional teams, most learning still takes place offline, through shared practices within their own institution. For example, the OERu institutional member who was interviewed said that the actual deep learning happens within his own institution:

I mean sure there's lots of reflections within the network, but most of those reflections tend to be offline. There's a lot of offline reflection between partners sharing their experiences and helping to inform the process.... [O]ne of the biggest challenges we face in the OER movement at the moment, is crossing the chasm ... from sharing to learn, to learning to share. (cited in Witthaus, 2013b)

## Conclusion

Our study is based on six different cases that share commitment to OEPs. In order to present truly generalizable results, more data is needed. However, our findings resonate with the experiences of practitioners and can thus provide other practitioners with starting points for initiating and developing OEPs.

The analysis of the social configuration of the six OEPs investigated provided evidence that within one initiative, different social configurations can be embedded (institutional teams, open networks of practice, and a strong community) with different roles, goals, and learning platforms.

Through the investigation of these social configurations, our analysis contributed to an understanding of how social learning activities are taking place. Although members do learn about the practicalities of using OEPs within institutional teams, the participation in open networks of practice does give access to the needed external expertise. Professionals increasingly see participation in open practices as a requirement for professional learning. These open networks of practice are dispersed across geographical and organizational boundaries, are informal and self-directed by nature, and disentangled from hierarchy. Open networks of practice have the potential to offer professionals a more dynamic and more useful 'platform' than CoPs for staying abreast in a rapidly changing profession. However, it is the long-lasting sub-communities and a strong coordinator that provide the drive to enable knowledge that could sustain and empower the knowledge sharing within open networks of practice. Interestingly, there is always some element of the practice geared to continual adaptation and change. Within these sub-communities there are clear forms of collaborative knowledge building, mediated by a variety of technological tools, which might be adapted to newly arising needs. This implies that it is wise, when attempting to build sustainable OEPs, to build on existing, long-standing communities, as this is likely to lend sustainability to the initiative.

In the cases involving instrumental networks, it was mostly suggested that individual motivation was central to active participation, at the same time showing an (overarching) institutional commitment. A typical example would be where specific project funding has been obtained for the development of resources. In these cases, central coordinators may continue to play an important role in sustainability.

In addition, working towards (the maintenance of) a shared identity will help in the creation of sustainable OEPs. Our investigation of this dimension seems to suggest that cases reporting a shared identity had a common view of the value of learning and were aiming to engage in and support knowledge co-creation; their aim was not in the first place instrumental.

Experiencing being part of a community with a shared practice and identity might necessitate the sporadic organization of face-to-face encounters. Co-production seems

easier to achieve by institutional teams and the constitution of open, trusting, and collaborative relations is still a challenge in totally mediated environments.

## Discussion

This study shows that social learning is complex and dynamic, and relies on supporting structures whether they are based on learning in teams, open networks of practice, or communities. Although the configuration includes different practices and interactional repertoires, learning activities take place at all levels but in different forms and at different levels of intensity (Schreurs, et al., 2014).

The applied framework helps us to further understand how to possibly connect social learning at various levels of scale (Hoppe & Suthers, 2014). The empirical findings reported in this study show evidence that within an OEP initiative there are multiple forms of participation possible at various levels (and at the same time). For some people it is enough to 'dip in and out' and see the OEP as a potential networking environment and treat it as a source of knowledge and potential learning ties. Occasionally one might take a keen interest in a particular topic or aspect and join a smaller group, that is, a 'team', to help solve a certain issue at hand. Or people might feel that this OEP community provides a kind of home-base and treat it as a community that also provides networking opportunities and the ability to start up temporary sub-groups or teams for particular tasks. The study shows therefore that OEPs facilitate networking, where openness allows the opportunity to meet and participate (a construct perhaps similar to the notion of legitimate peripheral participation (Lave & Wenger, 1991), but one does not necessarily need to become a core member. This networking 'layer' is likely to be connected with one (or more sub-) communities dedicated to developing a sense of belonging and maintaining long lasting productive relationships stewarding a shared domain. At a lower level of granularity within the OEP we have seen that teams or taskforces can emerge to solve an immediate problem. Participation within these teams can be drawn from the community or network level. This structure seems to align with the theoretical framework developed by Dron and Anderson (2014) where they identify nets, sets, and groups. They also recognize the fact that these social forms overlap and/or blend, but the extent to which they are connected at various levels is an issue for further research. The notions of (dynamic) nested forms of social configuring was also found in a study by Doornbos and De Laat (2012) where within an open network of practice on teacher professional development, there was a similar dynamic and mixture of social configurations. In their study they found that the network even took on external requests based on their recognition and status as experts in their field and applied a team-based structure to deliver as well as share their findings within their open network of practice promoting therefore a form of collective intelligence (Dron & Anderson, 2014). The extent to which the open networks of practice in the current study show evidence and how this contributes to innovation and learning is a topic for further research. Dron and Anderson (2014) argue for example that safety is an important

factor to stimulate social learning. Especially in sets anonymity could create a safe atmosphere for participants. This could be the case for teachers who use online platforms such as the Dutch initiative Wikiwijs intended at sharing educational materials, as in a recent study teachers claim to be reluctant to use this platform because they are afraid of being judged by colleagues. The importance of safety is also found in other studies (cf. Van den Beemt, et al., 2014).

A final issue worth mentioning in the discussion is how these theoretical and practical frameworks can help to promote and assess learning and the value that these open practices produce. Now that professionals join these open practices outside the organizations they work for (and meet and collaborate with self employed professionals) it will be even more difficult to manage and recognize valuable knowledge or skills within an organization. Participation in open practices challenges the more traditional forms of career path development, intellectual property, and organizational human resource management systems. At the same time, it provides new opportunities for those organizations and individuals that are open to exploring the benefits of collaboration and co-construction of knowledge beyond institutional boundaries.

## Acknowledgements

This study is conducted within the frame of the POERUP project, funded by the lifelong learning program of the European Commission (POERUP, 2013). The POERUP project aims to enable the development of policies to stimulate the uptake of open educational resources. Within the POERUP project, partners from the Open University of the Netherlands, Sero Consulting and the University of Leicester, and the University of Athabasca collaborated to gather all the data with help from the OEP initiatives under investigation.

## References

- Admiraal, W., Lockhorst, D., & van der Pol, J. (2012). An expert study of a descriptive model of teacher communities. *Learning Environments Research*, 15(3), 345-361.
- Bottrup, P. (2006). Learning in a network: A “third way” between school learning and workplace learning?. *Journal of Workplace Learning*, 17(8), 508-520.
- Boud, D., & Hager, P. (2012). Re-thinking continuing professional development through changing metaphors and location in professional practices. *Studies in Continuing Education*, 34(1), 17-30.
- Brown, J. S., & Duguid, P. (2001) Knowledge and organization: A social-practice perspective. *Organization Science*, 12(2), 198 – 213.
- Büchel, B., & Raub, S. (2002). Building knowledge creating value networks. *European Management Journal*, 20(6), 586-596.
- De Laat, M. F., Schreurs, B., & Nijland, F. (2014) Communities of practice: Balancing openness, networking and value creation. In R. F. Poell, T. S. Rocco & G. L. Roth (Eds.), *The Routledge companion to human resource development*. London: Routledge.
- Dechant, K., Marsick, V. J., & Kasl, E. (1993). Towards a model of team learning. *Studies in Continuing Education*, 15(1), 1-14.
- Doornbos, A., & de Laat, M. (2012). De waarde van communities of practice in het groene onderwijs. [*The value of communities of practice in green education*] (Report). Ede: GKC.
- Dron, J., & Anderson, T. (2007). *Collectives, networks, and groups in social software for elearning*. World Conference on E-Learning in Corporate, Government, Healthcare, and Higher Education (ELEARN) 2007, Quebec City, Quebec, Canada.
- Dron, J., & Anderson, T. (2014). Agoraphobia and the modern learner. *Journal of Interactive Media in Education*. Retrieved from <http://www-jime.open.ac.uk/jime/article/view/2014-03>
- Fetter, S., Berlanga, A. J., & Sloep, P. B. (2011). Peer-support and open educational resources. *Collaborative Learning*, 2.
- FutureLearn. (2013). *Futurelearn launches*. Retrieved from <http://futurelearn.com/feature/futurelearn-launches/>

- Galley, R., Conole, G., & Alevizou, P. (2012). Community indicators: A framework for observing and supporting community activity on Cloudworks. *Interactive Learning Environments*. DOI: 10.1080/10494820.2012.680965
- Glaser, B. G., & Strauss, A. L. (2009). *The discovery of grounded theory: Strategies for qualitative research*. Transaction Publishers.
- Hoppe, H. U., & Suthers, D. D. (2014, March). Computational approaches to connecting levels of analysis in networked learning communities. In *Proceedings of the Fourth International Conference on Learning Analytics And Knowledge* (pp. 285-286). ACM.
- Knapp, R. (2010). Collective (team) learning process models: A conceptual review. *Human Resource Development Review*, 9(3), 285-299.
- Lane, A. (2008). Reflections on sustaining open educational resources: An institutional case study. *eLearning Papers*. Retrieved August, 31, 2010 from [http://www.elearningpapers.eu/index.php?page=doc&doc\\_id=12405&doclng=6&vol=10](http://www.elearningpapers.eu/index.php?page=doc&doc_id=12405&doclng=6&vol=10)
- Lave, J., & Wenger, E. (1991). *Situated learning: Legitimate peripheral participation*. Cambridge University Press.
- Lohman, M. C. (2006). Factors influencing teachers' engagement in informal learning activities. *Journal of Workplace Learning*, 18(3), 141-156.
- POERUP. (2013). *Policies for OER uptake. Progress report*. Retrieved from [http://poerup.referata.com/w/images/2011\\_4021\\_PR\\_POERUP\\_pub.pdf](http://poerup.referata.com/w/images/2011_4021_PR_POERUP_pub.pdf)
- Pugh, K., & Prusak, L. (2013). Designing effective knowledge networks. *MIT Sloan Review*. Retrieved from <http://sloanreview.mit.edu/article/designing-effective-knowledge-networks/>
- Salas, E., Dickinson, T. L., Converse, S. A., & Tannenbaum, S. I. (1992). Toward an understanding of team performance and training. In R. W. Swezey & E. Salas (Eds.), *Teams: Their training and performance* (pp.3-29). NJ: Ablex.
- Schreurs, B., Van den Beemt, A., Prinsen, F., De Laat, M., Witthaus, G., Conole, G. (2014). *Investigating the social configuration of a community to understand how networked learning activities take place: The OERu case study*. Paper presented at the 2014 Networked Learning Conference, Edinburgh, UK.
- Van den Beemt, A., Ketelaar, E., Diepstraten, I., & De Laat, M. (2014). *Reciprocity in knowledge networks*. Paper presented at the 2014 Networked Learning Conference, Edinburgh, UK.



- Vrieling, E., Van den Beemt, A., & De Laat, M. (in press). What's in a name: Dimensions of social learning in teacher groups. *Teachers and Teaching: theory and practice*.
- Wenger, E. (1998). *Communities of practice: Learning, meaning, and identity*. Cambridge University Press.
- Wenger, E., Trayner, B., & de Laat, M. (2011). *Promoting and assessing value creation in communities and networks: A conceptual framework*. The Netherlands: Ruud de Moor Centrum.
- Witthaus, G. (2013a). The OERu is smart philanthropy: Interview with Wayne Mackintosh. *ILI Blog* August 14th. Retrieved from <http://beyonddistance.wordpress.com/2013/08/14/the-oeru-is-smart-philanthropy-interview-with-wayne-mackintosh/>
- Witthaus, G. (2013b). In the OERu, education is something that grows as it shares: An interview with Haydn Blackey. *ILI Blog* August 15th. Retrieved from <http://beyonddistance.wordpress.com/2013/08/15/in-the-oeru-education-is-something-that-grows-as-it-shares-an-interview-with-haydn-blackey/>
- Witthaus, G. (2013c). As I was contributing, I was learning: An interview with Bernard Nkuyubwatsi. *ILI Blog*. Retrieved from <http://beyonddistance.wordpress.com/2013/08/16/as-i-was-contributing-i-was-learning-an-interview-with-bernard-nkuyubwatsi/>

Athabasca University 





## Learners' Views Regarding the Use of Social Networking Sites in Distance Learning

Büşra Özmen and Bünyamin Atıcı  
Fırat University, Turkey

### Abstract

In this study, it was aimed to examine the use of learning management systems supported by social networking sites in distance education and to determine the views of learners regarding these platforms. The study group of this study, which uses a qualitative research approach, consists of 15 undergraduate students who resumed their education in Turkey. The data were gathered via a semi-structured interview form which consists of open-ended questions. Content analysis was used in the analysis of the data. According to the results of the study, it has been revealed within the scope of the course that the students have positive attitudes towards the use of social networking sites and distance education applications and these applications have positively affected the quality of communication between instructors and students. Furthermore, it was seen that the students made comments relating to the interesting aspects of the applications and the difference between distance education and face-to-face learning.

**Keywords:** Social networking sites; distance learning; learning management systems; Blackboard; CourseSites; Ning

## Introduction

Distance education has existed for more than a hundred years. Distance education, which emerged with the idea of education at home without being dependent on time and place, has existed in many forms for years from learning via letters to videos, from radio and TV lessons to internet applications as technology has improved (Gürkan, 2012). Because of this, many different tools and methods have been used for realizing distance education activities (Smith, 2009). Within the scope of life-long learning, today, web technologies are actively used in distance education applications which aim to bring people in different places together. These technologies help people to learn by themselves synchronously or asynchronously and provide opportunities for creating an interactive environment via audio-visual elements. Student-student interaction is seen as one of the key points in providing student satisfaction in distance education (Zhao et al., 2005; Tallent-Runnels et al., 2006). In addition, it has been stated that interaction in learning increases success and engenders a positive attitude, an increase in motivation, and consequently more meaningful and permanent learning (Kim et al., 2007). The negative effects of earlier distance education applications and the use of internet technologies that do not meet needs in terms of learner-learner and learner-instructor interaction have decreased. The use of learning management systems (LMSs), such as Blackboard, Moodle and WebCT, which were often used in higher education institutions in the 1990s, has not only facilitated the distribution and sharing of education material and information, but also increased the level of interaction among learners, institutions, and instructors. Tools such as instant messaging systems, discussion boards, chat rooms, and blogs have given learners the opportunity to interact not only with instructors but also with other learners (Grisham & Wolsey, 2006). However, recently it has been seen that these overly structured (Brady, Holcomb, & Smith, 2010) tools used in LMSs make some students reluctant to use these platforms (Aghili et al., 2014; Divall & Kirwin, 2012; Meishar-Tal, Kurtz, & Pieterse, 2012; Schroeder & Greenbowe, 2009) as they provide less student communication, satisfaction and motivation when compared to the face-to-face classroom environment from the perspective of students (Aghili et al., 2014; Thoms & Eryilmaz, 2014; Meishar-Tal, Kurtz, & Pieterse, 2012; Rozac et al., 2012; Duncan & Young, 2009; Young, 2007). LMSs are also tending to be instructor centric and instructors primarily use these platforms for information sharing (Mott, 2010). In these official environments, learners are limited to merely interacting with others. Furthermore, LMSs are considered to decrease motivation and enthusiasm and fail to support personalization (DeSchryver et al., 2009).

For this reason, the researchers have suggested that the aforementioned platforms get support from other technologies in order to resolve these problems and provide social experience (Brady, Holcomb, & Smith, 2010; Lee & McLoughlin, 2010). Within this scope, social networking sites (SNSs) have caught attention due to their encouragement of communication (Rozac et al., 2012), student engagement (Aghili et al., 2014), motivation, personal interaction and collaboration (Veletsianos, Kimmons, & French,

2013; Veletsianos & Navarrete, 2012; Greenhow, Robelia, & Hughes, 2009). It was considered that SNSs can be used to overcome the limitations of LMS (Aghili et al., 2014; Tess, 2013; Veletsianos, Kimmons, & French, 2013; Veletsianos & Navarrete, 2012; Wang, 2011).

SNSs are defined as web sites which provide opportunities for users to increase levels of communication by connecting with one another and to share personal content, features which are the basic characteristics of online communities (Buss & Strauss, 2009). According to Junco and Mastrodicasa (2007), SNSs are “*an easier way to connect in a disconnected world.*” Wheeler, Yeomans, and Wheeler (2008) state that SNSs provide unique opportunities for students to share their ideas, showcase their creativity, and get rapid feedback from their friends. SNSs which are designed to form virtual groups via the sharing of experience and personal information and connecting with friends are increasing day by day in today’s world. Although there are many SNSs such as Bebo, LunarStorm, Mixi, and Orkut, the most popular ones are Facebook, MySpace and Twitter. These sites have increasingly become an essential communication tool for people (Brady, Holcomb, & Smith, 2010). Individuals with common interests can connect by sharing information in the form of photos, videos, links, and notes; and they can collaborate by using discussion environments (McCann, 2009). In particular, SNSs help people who have problems with initiating and maintaining formal or informal social relationships as they decrease communicative barriers and encourage people to make interactions, as is the case with some other types of computer-supported communication (Ellison, Steinfeld, & Lampe, 2007). Many researchers support the use of SNSs in increasing student engagement and forming communities in higher education classes (Aghili et al., 2014; Hoffman, 2009). According to a report prepared by New Media Consortium and ELI (2007), not only do SNSs attract people, they also attract their attention, foster their participation, and lead users to revisit past experiences, all of which are seen as desirable qualities in educational materials. SNSs give learners an opportunity to create personal profiles which help them take ownership of their learning space (Meishar-Tal, Kurtz, & Pieterse, 2012). SNSs are also useful tools for creating a sense of presence, supporting student participation, and building online communities (Lee & McLoughlin, 2010; Naveh et al., 2010). Furthermore, it was stated that SNSs can improve learners’ high order thinking skills depending on the tasks instructors choose (Callaghan & Bower, 2012; Lu & Churchill, 2012). For all of these reasons, the use of SNSs is significantly beneficial, especially in higher education contexts. But some researchers have suggested not using SNSs due to their disadvantages for learners and instructors such as feeling less safe with personal data and exposing distractions in the learning environment (Petrovic et al., 2014; Meishar-Tal, Kurtz, & Pieterse, 2012).

To summarise, the use of LMSs as primary education tools, especially in higher education institutions, is rapidly increasing (Petrovic et al., 2014; Brady, Holcomb, & Smith, 2010). According to a study by Allen and Seaman (2008), the rate of high school and university students registering in at least one such class is increasing day by day. At

the same time, the popularity of SNSs such as Facebook, Friendster, LinkedIn, LiveJournal, and MySpace is continuously increasing and it has expanded to a wide user base (Boyd & Ellison, 2007). When the popularity of LMSs and SNSs and the educational benefits of SNSs are considered, some educators suggest merging these two platforms to improve the quality of learning (Petrovic et al., 2014; Thoms & Eryılmaz, 2014; Razali et al., 2013; Iahad, 2012; Rozac et al., 2012; Brady, Holcomb, & Smith, 2010; Feuer, 2009). In this context, it was aimed to investigate students' views about the use of LMSs supported by SNSs in distance education in this study.

## Method

### The Model of the Study

This study, which uses a qualitative research approach, has been designed as action research. Action research provides in-depth information to the researcher about the process and results of the application. In addition, it is more often used as part of a qualitative research approach because generalization is not the primary purpose and qualitative research has a more flexible structure than quantitative research (Yıldırım & Şimsek, 2008). From this standpoint, it has been attempted to determine what learners think about the application process and to record the results of social networking site supported distance education courses which were carried out in the course of the study.

### Study Group

The population of the group consists of Firat University students. Criterion-based sampling was selected from the purposeful sampling methods in determining the study group. In criterion-based sampling, the study group is formed by selecting the ones that meet the formerly determined criteria. A ready-made criterion list can also be used in addition to one prepared by the researcher (Patton, 2002). For this purpose, the criteria were formulated by the researcher. In the study, the participants were chosen from 25 students who participated both in social network and distance education applications within the scope of the experimental study, which was carried out in relation to the support of distance education systems with SNSs, during the 2011-2012 spring term at Firat University. In selecting the study group, active participation in distance education and social network applications, high-level expression skills, and the desire to participate voluntarily were taken to be the criteria. First of all, 16 students who had actively participated in distance education and social network applications and who had demonstrated high-level expression skills during the process of the applications were chosen, then they were asked whether or not they were willing to volunteer for the interview stage. Interviews were conducted with 15 students who said that they were willing to volunteer for the study.

## Data Collection

Data were collected with the interview form developed by the researcher, with which the views of the learners were related to the application process of the research. The interview was prepared in accordance with the semi-structured interview type and an individual interview was carried out. The interviews were carried out following the completion of the application process. The questions in the interview form were related to certain topics such as the differences between the applications from the perspectives of the learners, positive and negative aspects of the applications, their effects on communication, interesting aspects, hardships in usage, their wish to use them in professional life and for them to be used in the other courses. For this purpose, an interview form was developed in the first stage. The studies related to the topic in the literature were examined and 18 open-ended questions were written in accordance with the principles to be paid attention to in preparing the interview form. After that, in a collaborative study between two experts and the researcher, the questions were reviewed and, as a result, a form was prepared consisting of 10 questions. All interviews were conducted in the Firat University Faculty of Education. During the interviews, a flexible method was followed in asking the questions in accordance with the structure of the semi-structured interview, and when seen as necessary, more in-depth information was acquired by asking more questions. At the same time, the questions were asked in a conversational manner and after stating that the subjects' names would be kept secret, an attempt was made to create a warmer and more intimate environment, and, therefore, the students were more comfortable. The researcher was the interviewer in all interviews. The researcher placed importance on encouraging the participants to give detailed information and give feedback to the responses he/she gave in order to provide an efficient interview during the interview process. In the study, all interviews were recorded. A word processor program was used for enabling later analysis of the recordings and written copies of them were prepared. In addition, the interviews were recorded without modifying any of the students' views.

In the study, CourseSites, which is the free software provided by Blackboard, was used in carrying out the distance education applications; and Ning, a social networking site, was used in carrying out the social network applications. Ning helps to simulate a class environment by designating an area which is exclusive to certain courses to which only members can have access thus increasing the participation of the students in internal and external activities.

## Data Analysis

Within the scope of the study, the qualitative data attained were analyzed in accordance with content analysis principles. Content analysis is defined as the process of reaching a set of concepts and relationships within which the data can be analyzed. Providing a deeper analysis, it is used in revealing the concepts and themes that could not be formed as a result of descriptive analysis. With content analysis, data which are similar are gathered under certain concepts and themes and these data are interpreted by arranging

them in a way that the reader can understand. For this purpose, the data are firstly conceptualized, then the occurring concepts are arranged in a systematic way and, finally, the themes explaining the data are formed and the process is completed (Strauss & Corbin, 1990).

Within the scope of data analysis, the first step of the transmission of recordings attained from the interviews to the digital environment was conducted via a word processor program. Then, for the purpose of conducting a valid and reliable analysis, it was decided that the process should be conducted in a computer-supported way. Qualitative data analysis software was used which provides opportunities for visual outputs to be created as a result of the analysis. In the analyses conducted, the written source, which was transmitted to the electronic environment, was first read carefully. Then, the coding process was initiated and free code lists were formed. After a detailed examination of the free code lists, the codings were systematically grouped and categorized. The qualitative data analysis process was complete once the themes had been formed.

## Results

### Differences between the Distance Education Process and the Face-to-Face Education Process

The views of learners related to the differences between the distance education and the face-to-face learning activities were examined under two themes: course environment and physical environment (Figure 1).

The students put the most emphasis on the process of listening to the course related to the differences between the distance education activities and the face-to-face learning activities. When the loads were examined more carefully, not having items that distract attention was the topic which was most talked about, and the rest follow in sequence: providing more chances to express oneself more carefully, distraction of excessive use of chat rooms, providing active participation, saving more time, providing chances for getting immediate feedback, provision of the opportunity to repeat, the course may not be listened to, the control of the process of listening to the course belongs to the students, interacting with foreigners makes people worried. The topic with the second greatest degree of emphasis was the physical environment. The remaining sub-themes have been ranked in sequence in descending order of degree of emphasis: it is not dependent on the place, the worry of not being face-to-face, the screen provides visual easiness, distraction by people who have nothing to do with the course. Below are some samples from the views of students which are the sources for these sub-themes.

In face-to-face education, the door is opened and I get distracted, my friends talk to each other and I get distracted, certainly there is always something to distract me. However, I have noticed that in my room, I focus only on the computer. (Student L)

I have the ability to talk when a friend sits near me in traditional environments and I talk to him/her. However, there was not anything like this in virtual classroom. I have listened to the course directly because there was nobody near me to talk to. (Student D)

Because there is a seating order in traditional education, sometimes we have had problems in seeing the slides, students or the teacher, but we can see the board directly in the virtual classroom. (Student A)

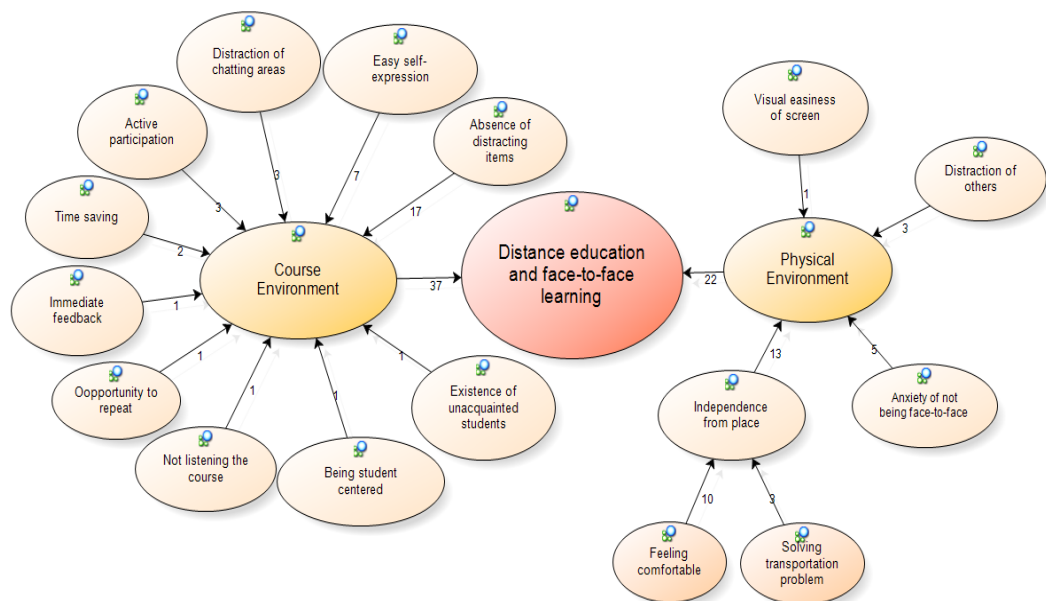

Figure 1. The differences between the distance education process and the face-to-face education process.

## Participation in Activities in the Social Networking Site

Students stated that there was a high degree of participation in the social networking site and distance education platform. Information relating to the participation of the students in social networking activities has been gathered under four sub-themes: the



contribution of the sharings, increasing communication, giving chances to get to know these kinds of environments, and solutions to communication problems (Figure 2).

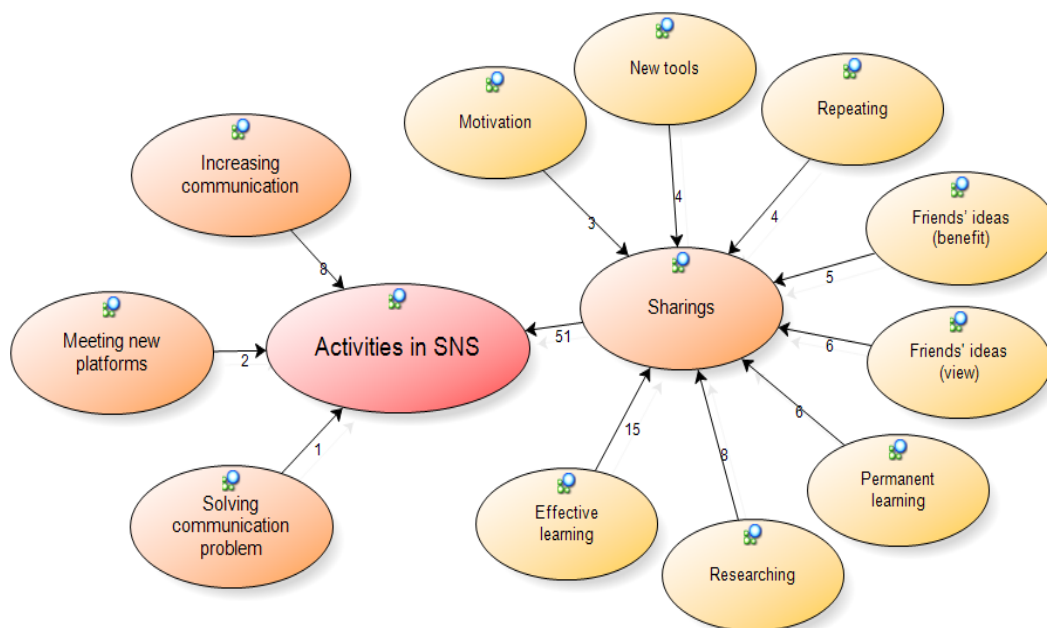

Figure 2. The model related to the participation in activities in the social networking site.

In particular, the students' level of participation in sharing caught our attention in the participation coding of activities carried out within the scope of applications conducted in the social networking process. With regard to the interviews, it was seen that there were eight different sub-categories arising from the detailing of the loads belonging to the themes. These sub-categories were sequenced in the following order: provision of efficient learning, nudging students towards research, provision of permanent learning, viewing friends' ideas, benefitting from friends' ideas, provision of the opportunity to repeat, the use of tools which cannot be provided in the face-to-face classroom environment, and increase in motivation.

We can learn in a broader way when we read and analyze both our answers and the answers of our friends. (Student F)

It encouraged me to research further, because actually there was a matter of comparison. I saw what my friends had written, and it forced me to think like Can I write a better one? Can I share more efficiently? (Student H)

It makes a person glad also in terms of himself/herself to be sharing new things about the course together with the



instructors and our friends... The instructor's feedback to the sharing of information motivates us. (Student E)

## Positive and Negative Aspects of Distance Education Courses

When the views of students related to the themes are examined in detail, it is noteworthy that the students put more emphasis on the positive aspects of distance education courses. In addition, while the sub-theme on which the most positive emphasis was put is independence of time and place, the sub-theme on which the most negative emphasis was put is distraction of excessive use of chatting areas (Figure 3).

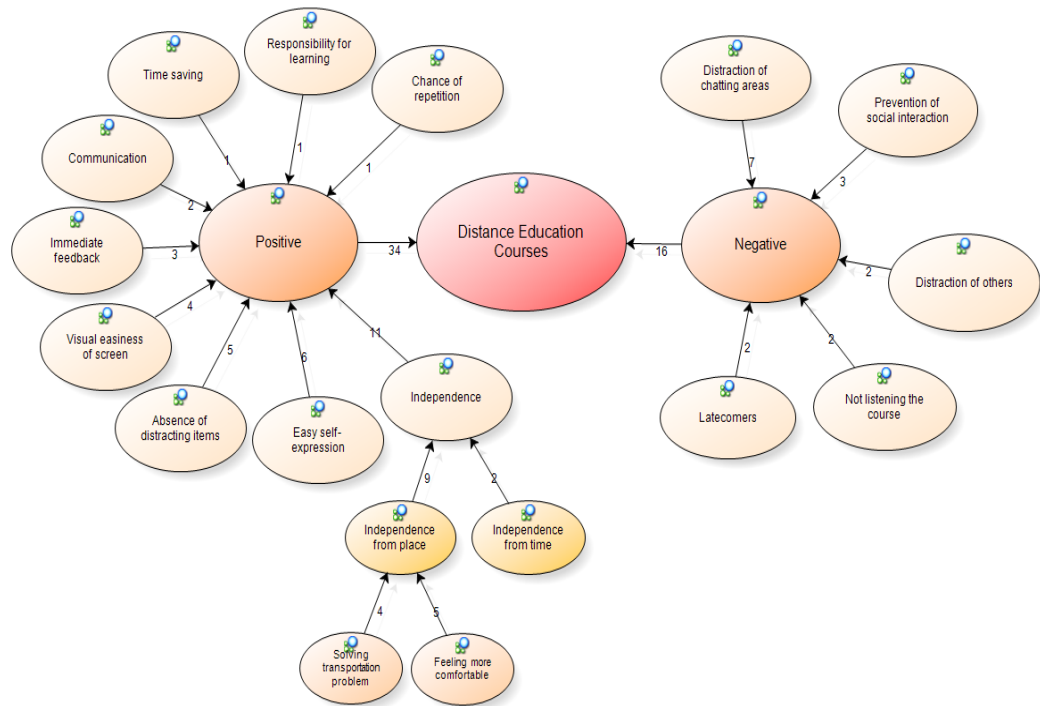

*Figure 3.* The model related to the positive and negative aspects of lecturing in the distance education platform.

When the views of students were examined, it was determined that the theme with the most positive views has eight sub-categories. These subthemes have been sequenced in descending order as follows: independence of time and place, provision of easy self-expression, not having items that distract attention, visual easiness of the screen, provision of immediate feedback, increasing the level of communication, saving time, and provision of the opportunity to repeat. It can be seen that independence of time and place, the theme which has the most positive emphasis, has been separated into two sub-themes, independence of time and independence of place; and the independence of place sub-theme has been further separated into two sub-themes, feeling more comfortable and solution to transportation problems. The most negative aspect of

distance education applications was stated to be the distraction of excessive use of chatting areas by the students during the course. And distraction by people who have nothing to do with the course, the course may not be listened to, and waiting for latecomers follow this theme.

The courses could be in our homes because there was not any problem of going to school and coming back from the school... We had the opportunity to listen to the course any time, wherever we are. (Student O)

I am a person who gets distracted in face-to-face education, but I did not get distracted so much in there. I was totally focused on the lesson and understood it better. (Student L)

It destroys the social interaction... it prevents the continuity of communication. However, there is a chatting area, but again, the reciprocal interaction; I think that reciprocal communication is better. (Student K)

There can be different people in the environment because you are in the environment you want to be in. Because I live in the dormitory, my friends were entering the room and I got distracted by them. (Student A)

Off-topic messaging affected me negatively. (Student L)

## Negative Aspects of Using the Social Networking Site

The majority of the students said there is no negative aspect to the benefits they receive from using a social network in the education process. It was also seen that the other students talked about some negative aspects. These negatives have been gathered under themes such as sharings, reluctance of students in attending to the environment, and not being able to delete messages in the chatting area.

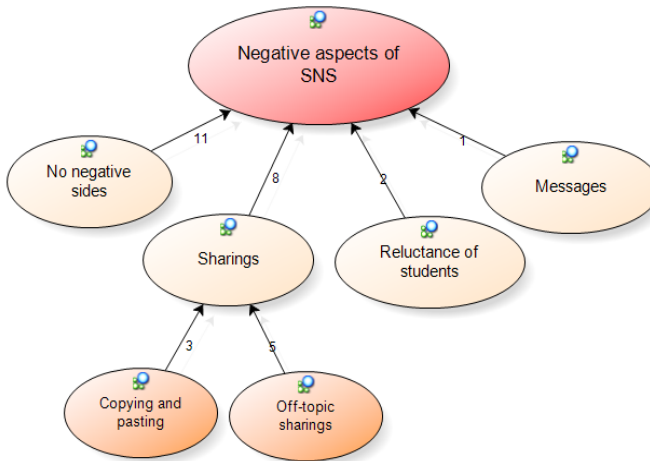

Figure 4. Model related to the negative aspects of using the social networking site.

With regard to the interviews conducted with the students, it is seen in Figure 4 that the theme sharings is separated into the two sub-themes, sharings which are not related to the topic and using copy and paste.

I cannot see the negative aspects of it so much. It is positive in general. (Student J)

I think there are no negative aspects, because I have always seen the positive aspects of it. (Student D)

Some of us have also shared things which were not related. (Student L)

## Communication in the Application Platforms

The majority of the students stated that the activities carried out both in distance education and through the social network affected their relationships positively both with their friends and the instructors. However, it is also noticeable that the application either did not have any effect on the relationships between some students or negatively affected some relationships. The model related to communication in the application platforms is presented in Figure 5.

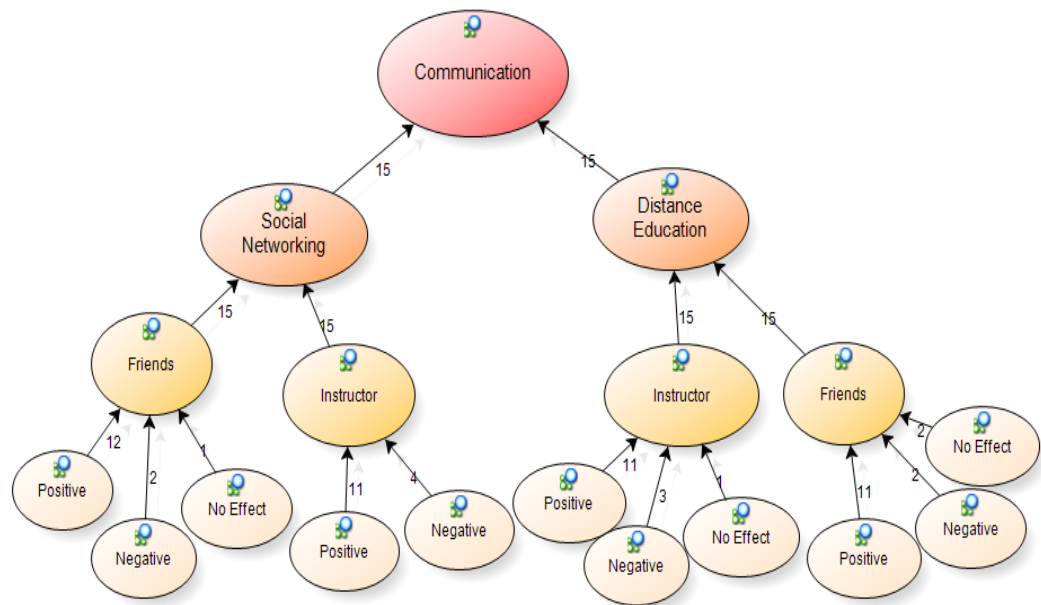

Figure 5. Model related to communication in the application platforms.

I think it has a positive effect. I believe that we have better quality communication with the instructor in the virtual classroom. (Student J)

We had a greater level of interaction with our friends. We had the opportunity to communicate with everybody due to the chat rooms. (Student A)

It has increased... we spent more time there, we talked about some things and shared information, and now we are closer... Our discussion in there has been reflected in our work after classes and we got on well. It has been better. (Student L)

It negatively affects us. It is impossible to capture the environment of a real classroom via the virtual classroom. (Student K)

People you don't know, you become irritated by some of their behaviors. Because you have to be with them in that environment, you have to tolerate them and their activities actually. (Student I)

## Interesting Aspects of the Platforms

The responses given related to the interesting aspects of the platforms were separated into the two sub-themes, distance education and social network. The interesting aspects of the distance education platform are ordered as follows from most emphasized to least emphasized: providing communication as much as it can be done in face-to-face class, the completion of all activities that can be conducted as a whole class, attendance from wherever students want, gathering everyone in one place who participate from different places, presenting a different environment, having the properties like chatting, white board, sound and camera, the control of listening to the course belongs to the students, the visual ease of the slides in the screen, availability via just an Internet connection and an extension and not having a formal environment as it is in the traditional classes. For the social network platform, it is sequenced as sharings, indication of the existence of a social network for educational purposes, provision of efficient communication, availability for using anytime, and being more beneficial than expected. The model formed in relation to this theme is provided in Figure 6.

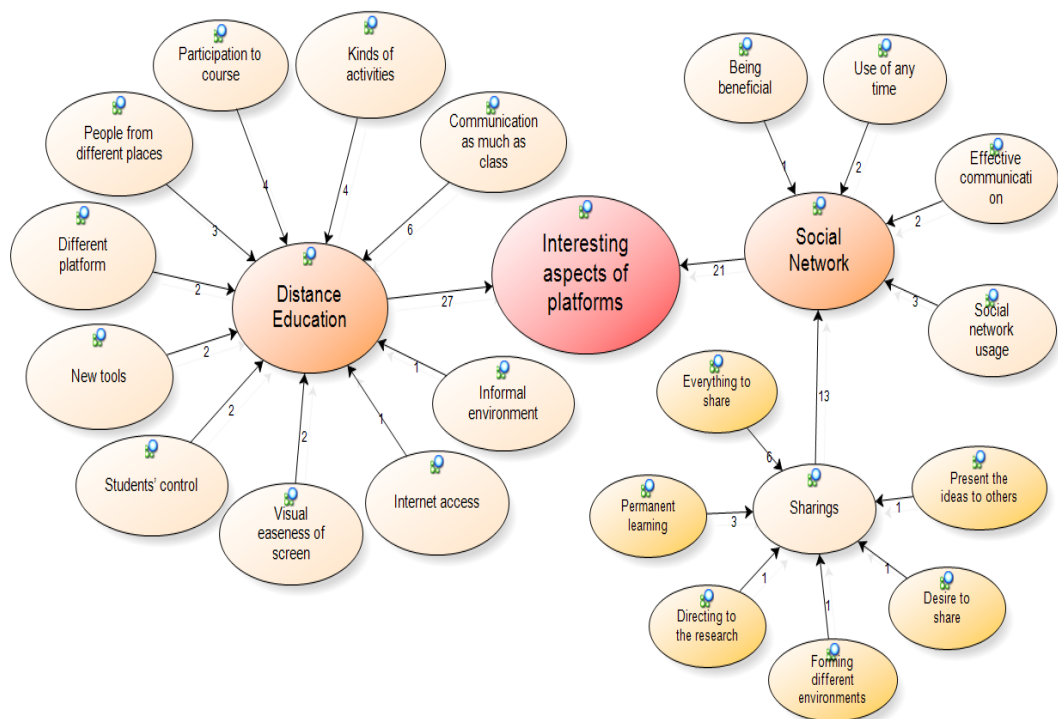

Figure 6. Model related to the interesting aspects of the platforms.

The sharings sub-theme which has the largest information load related to the social network platforms consists of six sub-themes in total: sharing anything wanted, provision of permanent learning, nudging students towards research, forming different

discussion environments, desire of sharing, and provision of the opportunity to share ideas with friends.

What caught my attention was seeing the instructor in front of us. I felt as if it was face-to-face. (Student H)

We can do anything we do in class there. We can participate in the courses. (Student J)

We were commenting freely... We were writing the suggestions we wanted to make. (Student N)

All our friends could access the questions and ideas we shared in the forums. And everybody could answer my question. (Student H)

## Discussion

In this study which was conducted on the effects of the learning management systems on learners' views, an attempt was made to suggest the primary differences between the distance education and the face-to-face learning process. It has been seen that the differences between each educational process depend on listening to the course and physical environment as two main topics. Students have explained that they cannot concentrate exclusively on the course because they want to chat with their friends in the face-to-face learning environment. However, they expressed that there is no such situation in virtual classroom activities conducted within distance education and they concentrate on the course because there are no distracting objects in the environment (Petrovic et al., 2014). Another important result in this issue is that the students both feel more relaxed and express themselves more easily in these environments. This result matches with the related reviews within the literature which concern the issues of students being more relaxed and expressing themselves more easily (Holcomb, Brady, & Smith, 2010). Examples of differences between the applications are being independent of location, being anxious due to not being face-to-face, the interface providing visual ease of use, and distraction of other students with whom students are not acquainted. The course environments being independent from location negates transportation problems and allows the student to relax in his/her environment.

Within the scope of the study, emphasis has been put on contributions in sharing, improving communication, providing an opportunity to meet such environments, and removing the communication problems concerning contributions of activities made in the social networking site. The students have indicated that the most important contribution in the activities made in this platform is sharing. Accordingly, in the literature, the students have indicated that they consider Ning, a SNS used in the present study, as providing ease in sharing ideas and engaging in discussion (Hoffman,

2009; Holcomb, Brady, & Smith, 2010). Moreover, it has been stated that the most important advantage of Ning is its allowance for individuals to upload videos, images, and files (Brady, Holcomb, & Smith, 2010). In addition, there are some results suggesting that the SNSs to be used must contain properties such as students being a member, the ability to create a profile page, share information, and to establish academic and social user groups (Gürkan, 2012). Detailed investigations in the present study have shown that students describe the benefits of sharing as its provision of effective and permanent learning experiences, the ability to view the opinions of their friends, the ability to utilize the opinions of their friends, its tendency to direct them to research resources, the fact that it allows them to repeat, its provision of tools which cannot be accessed in a face-to-face educational environment, and its tendency to improve their level of motivation. In the studies within the literature, it has been concluded that SNSs used for educational aims have improved communication (Smith, 2009). In addition, it has been stated that using SNSs in learning and teaching activities provides several advantages and the most important ones are student participation, motivation, personal interaction, and personal learning (Iahad, 2012; Meishar-Tal, Kurtz, & Pieterse, 2012; Veletsianos & Navarrete, 2012; Hoffman, 2009). Similarly, Mazer, Murphy, and Simonds (2007) state that SNSs affect the class environment positively and improve levels of motivation. In a study related to viewing the opinions of friends and utilizing their comments, it has been underlined that SNSs allow users to both see the opinions of friends on a certain issue and to utilize these opinions. In the same study, it was indicated that SNSs allow for thinking in order to view and answer friends' comments (Holcomb, Brady, & Smith, 2010). In addition, in the literature, it has been specified that sharing in a SNS is beneficial in relation to seeing the opinions of all members of a group. In the present study, students have stated that improvement in communication is another advantage of SNSs. Correspondingly, it has been stated in the literature that SNSs allow for better communication between students when distance education and face-to-face education are compared (Brady, Holcomb, & Smith, 2010).

The result of investigating the positive and negative aspects of LMS is that the students concentrate mostly on positive aspects. On the topic of independency from time and place, the aspect of independence of location especially comes to the forefront. This situation allows students to express themselves easily in the platform and negates transportation problems. However, as distinct from the present study, in the literature, there are studies in which students have indicated that they prefer the face-to-face learning environment in spite of the aforementioned positive aspects of SNSs (Brady, Holcomb, & Smith, 2010). Within the course, the students have indicated that the most negative aspect of using the virtual classroom, which is a technology of distance education, is the overuse of the chat area. It has been confirmed that this situation makes the students distracted in the course. Moreover, according to the results of the present study, attention has been drawn to the fact that some students think that distance education prevents socialization in spite of the opinions of other students. It has been seen that the same results have been reached from the studies within the literature; it gives less satisfaction to the student than face-to-face learning due to



distance education's prevention of face-to-face social interaction (Hoffman, 2009; Young, 2007); debate platforms used in LMSs make the students unwilling to participate and affects the quality of social interaction negatively (Schroeder & Greenbowe, 2009).

Another issue emphasized in the study is the determination of the negative aspects of using SNSs within the course. During interviews, most of the students stated that there are no negative aspects to it. Accordingly, in the literature, it has been stated that there are no negative aspects to usage of the Ning platform (Brady, Holcomb, & Smith, 2010). It can be said that using SNSs in educational activities creates a high level of motivation in the students. In addition, it has been emphasized that SNSs which allow expansion of the borders of the class can be used to educational ends (Karabulut, 2009). Negations in the process of social networking activities are not wishing to participate within the environment and not being able to delete text entered in the chat area. In this issue, interactions unrelated with the topic and the copying and pasting of another person's opinions have been considered as negations. Accordingly, Johannesen and Eide (2000) emphasize that students show respect towards others' opinions and they must not copy and paste information which they do not have in their studies. As distinct from the results of the present study, it has been suggested that SNSs such as Ning have a number of advantages but also some disadvantages and it has been stated that one of the most important disadvantages is time lost in students' replying to other interactions in the environment (Holcomb, Brady, & Smith, 2010).

The study has shown at what level distance education and social networking platforms affect student-student and student-instructor communication. Each platform affects the communication of students both with each other and with instructors positively. When it is considered that student-student interaction is the key point from the perspective of student satisfaction in distance education, it can be seen that it carries a great deal of importance (Thoms, 2014; Veletsianos & Navarrete, 2012; Meishar-Tal, Kurtz, & Pieterse, 2012; Tallent-Runnels et al., 2006; Zhao et al., 2005; Aijan & Hartshorne, 2008). In the present study, it was noteworthy that students who are shy in terms of establishing communication with the instructor in face-to-face learning environments have stated that they better cope with their shyness on the platform in question. Correspondingly, it has been stated that the introduction of SNSs in educational areas improves student-instructor communication, cooperation, interaction, and the quality of the e-education process (Meishar-Tal, Kurtz, & Pieterse, 2012; Despotovic-Zrasic, 2011). In the literature, it has been suggested that these environments provide communicative opportunity to individuals who cannot establish communication in face-to-face environments (Holcomb, Brady, & Smith, 2010); SNSs used for educational purposes can be an effective technological tool in order to develop online communication among students who take distance education courses in higher education (Brady, Holcomb, & Smith, 2010). Similarly, it has been emphasized that not only do online social network tools remove communicative barriers, they actively encourage communication (Bargh, McKenna, & Fitzsimons, 2002; Ellison, Steinfeld, &



Lampe, 2007). Moreover, it has been underlined that LMSs and SNSs must be used together in order to improve communication and interaction (McCarty, 2010).

In this process, the attractive aspects of the LMS and SNS whose activities were made have been evaluated. This situation can be considered as an indicator of the fact that students can establish communication in the LMS to the same degree that they can in the classroom environment and they can perform all activities which can be performed in the classroom environment in the LMS. It has been seen that the students find sharing to be most attractive. Benson (2009) stated that SNSs support information sharing by providing the participants opportunities to search, form common interest points, and partake in collaborative activities in distance education. Another important issue which has attracted the attention of the students on SNSs is the presence of a SNS which can be used for education and can be accessed only by the members. The studies made on this issue show that Facebook and Web 2.0 technologies are not always successful tools in learning and teaching activities; there is a difference between students' preferences when using these technologies for daily interaction with their family and friends and their preferences when using these technologies in formal education environments (Hoffman, 2009; Waycott et al., 2010; McCarthy, 2010). The students see using Facebook and other SNSs which they often use in their life for educational purposes can represent interference in their private lives (Aghili et al., 2014; Veletsianos & Navarrete, 2012; McCarthy, 2010; Hoffman, 2009; Schroeder & Greenbowe, 2009). In addition, these activities must be under the control of an administrator or an instructor in education environments due to confidentiality and security problems (Anderson, 2005). This is why it can be said that closed SNSs like Ning being used in education has developed dramatically.

When the results of the study are evaluated, it can be said that SNSs are supportive platforms to LMSs. Similarly, in the literature, it has been stated that supporting LMSs, especially those used in higher education, with SNSs is beneficial to effectively facilitate learning (Petrovic et al., 2014; Thoms & Eryılmaz, 2014; Razali et al., 2013; Iahad, 2012; Rozac et al., 2012; Gürkan, 2012; Despotovic-Zrakic, 2011; Brady, Holcomb, & Smith, 2010; Holcomb, Brady, & Smith, 2010; Anderson, 2005; Karabulut, 2009; Smith, 2009; Noesgaard, 2008). It should be noted that combining these two platforms provides more student engagement, personal interaction, communication, peer-to-peer feedback, and social experience in distance education. In this study, Ning was used as a social network platform. Ning is a social network platform which only members who are invited by the instructor can access. In future studies, other SNSs which are used for educational purposes can be investigated. Further research can also examine how to evaluate meaningful learning tasks to promote student engagement and collaboration in distance learning activities.

## References

- Allen, I. E., & Seaman, J. (2008). *Staying the course: Online education in the United States*. Needham, Mass: Sloan Consortium.
- Aghili, M., Palaniappan, A. K., Kamali, K., Aghabozorgi, S., & Sardareh, A. S. (2014). Unifying informal and formal learning environments: Educational use of social network sites through implementing community of inquiry framework. *International Journal of e-Education, e-Business, e-Management and e-Learning*, 4(3), 191-196.
- Anderson, T. (2005). Distance learning-social software's killer AP? *Conference of the Open and Distance Learning Association of Australia (ODLAA)*. Adelaide, South Australia: University of South Australia.
- Benson, V. (2009). Embedding web 2.0 strategies in learning and teaching. In Lytras, Miltiadis D., Damiani, Ernesto, Ordóñez de Pablos, Patricia (Eds.), *Web 2.0: The business model* (pp. 237-248). Springer US.
- Boyd, D. M., & Ellison, N. B. (2007). Social network sites: Definition, history, and scholarship. *Journal of Computer-Mediated Communication*, 13(1), 210-230.
- Brady, K. P., Holcomb, L. B., & Smith, B. V. (2010). The use of alternative social networking sites in higher educational settings: A case study of the e-learning benefits of ning in education. *Journal of Interactive Online Learning*, 9(2), 151-170.
- Buss, A., & Strauss, N. (2009). *Online communities handbook: Building your business and brand on the web*. USA: New Riders Press.
- Despotovic-Zrakic, M. S. (2011). Fostering engineering e-learning courses with social network services. *19th Telecommunications Forum TELFOR 2011.22-125*, 22-24 November 2011, Serbia, Belgrade.
- DeSchryver, M., Mishra, P., Koehler, M., & Francis, A. P. (2009). Moodle vs. Facebook: Does using Facebook for discussions in an online course enhance perceived social presence and student interaction? *The Society for Information Technology and Teacher Education International Conference 2009* (pp. 329-336).
- DiVall, M. V., & Kirwin, J.L. (2012). Using Facebook to facilitate course-related discussion between students and faculty members. *American Journal of Pharmaceutical Education*, 76(2).
- Duncan, H. E. & Young, S. (2009). Online pedagogy and practice: Challenges and strategies. *The Researcher*, 22(1), 17-32.

- Ellison, N. B., Steinfield, C., & Lampe, C. (2007). The benefits of facebookfriends: Social capital and college students' use of online social network sites. *Journal of Computer-Mediated Communication*, 12(4), 1143-1168.
- Feuer, G. (2009). *Net generation students and their use of social software: Assessing impacts on information literacy skills and learning at a laptop university*. University of Toronto, Department of Theory and Policy Studies Ontario Institute for Studies in Education, Toronto.
- Greenhow, C. G., Robelia, B., & Hughes, J. (2009). Learning, teaching, and scholarship in a digital age Web 2.0 and classroom research: What path should we take now? *Educational Researcher*, 38(4), 246–259.
- Grisham, D. L., & Wolsey, T. D. (2006). Recentering the middle school classroom as a vibrant learning community: Students, literacy, and technology intersect. *Journal of Adolescent & Adult Literacy*, 49(8), 648-660.
- Gürkan, S. (2012). *Açık ve uzaktan öğrenmede etkileşim aracı olarak web 2.0 teknolojilerinin kullanımı: kurumsal bir sosyal ağ sitesinin özelliklerinin belirlenmesi*. Anadolu Üniversitesi, Sosyal Bilimler Enstitüsü, Eskişehir.
- Hoffman, E. S. (2009). Evaluating social networking tools for distance learning. *Proceedings of Technology, Colleges, and Community Worldwide Online Conference*, 2009(1), 92-100.
- Holcomb, L., Brady, K., & Smith, B. (2010). Ning in education: Can non-commercial, education-based social networking sites really address the privacy and safety concerns of educators? In D. Gibson & B. Dodge (Eds.), *Proceedings of Society for Information Technology & Teacher Education International Conference 2010* (pp. 528-531).
- Iahad, N. A., Mirabolghasemi, M., & Huspi, S. H. (2012). *A blended community of inquiry approach: The usage of social network as a support for course management system*. International Conference on Computer & Information Science.
- Johannesen, T., & Eide, E. M. (2000). The role of the teacher in the age of technology: Will the role change with use of information and communication technology in education? *European Journal of Open and Distance Learning*.
- Junco, R., & Mastrodicasa, J. (2007). *Connecting to the net.generation*. Washington, D.C.: National Association of Student Personnel Administrators.

- Karabulut, A., Braet, D., Lindstrom, D., & Niederhauser, D. S. (2009). Student level of commitment and engagement with ning as a learning management system. In C. Maddux (Ed.) *Research highlights in information technology and teacher education 2009* in (pp.125-133). Chesapeake, VA: Society for Information Technology and Teacher Education (SITE).
- Kim, D., Grant, E., Huang, C., & Seo, J. H. (2007). Future design of Korean ubiquitous classrooms. Retrieved from <http://www.keris.or.kr/upload/board01/112903413.pdf> on 12.09.2012
- Lee, M. J. W., & McLoughlin, C. (2010). Beyond distance and time constraints: Applying social networking tools and Web 2.0 approaches to distance learning. In G. Veletsianos (Ed.), *Emerging technologies in distance education* (pp. 61–87). Edmonton, AB: Athabasca University Press.
- Lu, J., & Churchill, D. (2012). The effect of social interaction on learning engagement in a social networking environment. *Interactive Learning Environments, 1*, 1-17.
- Mazer, J. P., Murphy, R. E., & Simonds, C. J. (2007). I'll see you on Facebook: The effects of computer-mediated teacher self-disclosure on student motivation, affective learning, and classroom climate. *Communication Education, 56*(1), 1-17.
- Meishar-Tal, H., Kurtz, G., & Pieterse, E. (2012). Facebook groups as LMS: A case study. *The International Review of Research in Open and Distance Learning, 13*(4), 33-48.
- McCann, K. H. (2009). Virtual communities for educators: An overview of supports and best practices. *Technology, Colleges, and Community Conference 2009 Proceedings* (pp. 137-142). University of Hawai, Manoa,.
- McCarthy, J. (2010). Blended learning environments: Using social networking sites to enhance the first year experience. *Australasian Journal of Educational Technology, 26*(6), 729-740.
- Mott, J. (2010). Envisioning the post-LMS era: The Open Learning Network. *Educause Quarterly, 33*, 1-9.
- Naveh, G., Tubin, D., & Pliskin, N. (2010). Student LMS use and satisfaction in academic institutions: The organizational perspective. *The Internet and Higher Education, 13*(3), 127–133.
- New Media Consortium, & EDUCAUSE Learning Initiative (ELI). (2007). *The Horizon Report*. The New Media Consortium. Retrieved from <http://www.webcitation.org/5iJWOjmBq> on 09.08.2012

- Noesgaard, K. (2008). *Bridging eLearning and social networks*. University of Victoria, Department of Computer Science, Canada.
- Patton, M. Q. (2002). *Qualitative research and evaluation methods*. Thousand Oaks, CA: Sage.
- Petrovic, N., Jeremic, V., Cirovic, M., Radojicic, Z. & Milenkovic, N. (2014). Facebook versus Moodle in practice. *The American Journal of Distance Education*, 28,117–125.
- Razali, S. N., Shahbodin, F., Bakar, N., Hussin, H., Ahmad, M. H., & Sulaiman, N. (2013). Incorporating learning management system with social network sites to support online collaborative learning: Preliminary analysis. *Advances in Visual Informatics*, 8237, 549-557.
- Rožac, J., Buendía, F., Ballester, J., Kos, A., & Pogačnik, M. (2012). Integration of learning management systems with social networking platforms. In *eLmL 2012, The Fourth International Conference on Mobile, Hybrid, and On-line Learning* (pp. 100-105).
- Schroeder, J., & Greenbowe, T. J. (2009). The chemistry of facebook: Using social networking to create an online community for the organic chemistry laboratory. *Journal of Online Education*, 5(4).
- Smith, B. V. (2009). *Use of online educational social networking in a school environment*. North Carolina State University, Raleigh, North Carolina.
- Strauss, A. L., & Corbin, J. (1990). *Basics of qualitative research: Grounded theory procedures and techniques*. Newbury Park, CA: Sage.
- Tallent-Runnels, M. K., Thomas, J. A., Lan, W. Y., Cooper, S., Ahern, T. C., Shaw, S. M., & Liu, X. (2006). Teaching courses online: A review of the research. *Review of Educational Research*, 76(1), 93-135.
- Tess, P. A. (2013). The role of social media in higher education classes (real and virtual) – A literature review. *Computers in Human Behavior*, 29(2013), 60-68.
- Thoms, B, & Eryilmaz, E. (2014). How media choice affects learner interactions in distance learning classes. *Computers & Education*, 75(2014), 112-126.
- Veletsianos, G., Kimmons, R., & French, K. D. (2013). Instructor experiences with a social networking site in a higher education setting: Expectations, frustrations, appropriation, and compartmentalization. *Educational Technology Research and Development*, 61(2), 255-278.

- Veletsianos, G. & Navarrete, C. (2012). Online social networks as formal learning environments: Learner experiences and activities. *The International Review of Research in Open and Distance Learning*, 13(1), 144-166.
- Wang, Q., Woo, H. L., Quek, C. L., Yang, Y. & Liu, M. (2011). Using the Facebook group as a learning management system: An exploratory study. *British Journal of Educational Technology*, 43(3), 428-438.
- Waycott, J., Bennett, S., Kennedy, G., Dalgarno, B., & Gray, K. (2010). Digital divides? Student and staff perceptions of information and communication technologies. *Computers & Education*, 54(4), 1202-1211.
- Wheeler, S., Yeomans, P., & Wheeler, D. (2008). The good, the bad and the wiki: Evaluating student-generated content for collaborative learning. *British Journal for Educational Technology*, 39(6), 987-995.
- Yıldırım, A., & Şimşek, H. (2008). *Sosyal bilimlerde nitel araştırma yöntemleri*. Ankara: Seçkin Yayıncılık.
- Young, S. (2007). *On-campus and distance teaching: how do student ratings differ and what does that mean for improving instruction?* American Educational Research Association Annual Meeting, 10 October.
- Zhao, Y., Lei, J., Yan, B., Lai, C., & Tan, H. S. (2005). What makes the difference? A practical analysis of research on the effectiveness of distance education. *TeachersCollege Record*, 107(8), 1836-1884.

Athabasca University 



## Diving into Lake Devo: Modes of Representation and Means of Interaction and Reflection in Online Role-Play



Linda Koechli and Maureen Glynn  
Ryerson University, Canada

### Abstract

This paper outlines an action research project involving the development of an educational online role-playing website, known as Lake Devo. Designed in keeping with constructivist principles, the website is used in select post-secondary courses at Ryerson University and allows learners to work synchronously, using visual, audio, and text elements to create avatars and interact in online role-play scenarios. The website also provides an integrated area for debrief following role-play activities. The features of the website were deliberately intended to provide a viable alternative to text-only online role-play activities, while not requiring the highly sophisticated elements of 3D virtual environments. During the period of the project on which this article reports, learners were invited to use the Lake Devo website for an assigned role-play activity. Online learner survey responses were collected following the pilot implementations of the website to determine the extent to which the non-text modes of representation (visual, audio) in Lake Devo, along with an integrated debrief area on the site, supported the learners in their online role-play activity. The preliminary findings suggest that Lake Devo provides an environment that effectively supports online role-play. The simple format of the Lake Devo avatars, the availability of visual and audio elements, and the ability to create a lasting artifact for review in a dedicated debrief area engage students and also reinforce the constructivist and collaborative nature of role-play activities. For practitioners beyond the Lake Devo project team and the Ryerson context, the Lake Devo website provides an example of an online role-play environment that offers alternatives to text-based and/or 3D virtual worlds.

**Keywords:** Online role play; avatars; constructivist learning; collaborative learning



## Introduction

Over the past decade, educators have increasingly adopted role-play as an online pedagogical strategy in a number of contexts, including instructor training (Bell, 2001), international relations (Vincent & Shepherd, 1998), nursing (Nelson & Blenkin, 2007; Levitt & Adelman, 2010), and management (Jones, 2007; Liebowitz, 2003). Online role-play, as distinct from simulations or games, appears to be of particular value when learners are required to develop skills in interpersonal interaction (Feinstein et al., 2002; Russell & Shepherd, 2010).

The course used for this pilot study is an interdisciplinary course in “Conflict Resolution and Dispute Negotiation” (CINT905), offered by the Community Services Program Area at The G. Raymond Chang School of Continuing Education, Ryerson University. The course incorporates role-play as a teaching strategy in order to give learners the opportunity to practice communication and interpersonal skills within the context of a hypothetical face-to-face conversation. The instructor of the online offering of this course had originally conducted the role-play exercise using the Blackboard learning management system’s (LMS) discussion forum, similar to an approach described by Bender (2005). While the instructor reported that the text-based activity was effective in meeting learning objectives, she identified a need to improve the ease-of-use of the role-play, and expressed a desire to explore other modes of representation to increase learner engagement. Beyond the needs of this particular course, many other Ryerson instructors from a variety of subject areas had previously demonstrated an interest in online role-play, but had failed to incorporate it into their online course design. This may have been due to a range of factors, including the overall limitations of the LMS to facilitate implementation of constructivist strategies such as role-play (Lane, 2008). In addition, many instructors lacked the familiarity with other possible tools such as 3D virtual worlds and, as suggested in studies from other institutions, could not commit the time required to integrate such tools into their teaching (Moser, 2007).

The instructor of CINT905 turned to The Chang School’s Digital Education Strategies (DES) unit for assistance. The DES unit is a multi-disciplinary team of instructional designers, web developers, and editors who support online course development for The Chang School. The DES team works in a collaborative way with instructors and subject matter experts and brings a predominantly constructivist approach to its educational developments. Given the situation described above, the DES team saw the potential for an online learning environment that would provide an engaging experience using alternate modes of representation, and also offer a pedagogical framework that would encourage increased adoption of online role-play activities in general. As such, the team undertook the project to develop an online role-play website that would come to be named Lake Devo. The Lake Devo website was designed to provide an infrastructure for online role-play activities, while allowing for flexibility so that it could be used across disciplines, as well as in multiple delivery formats (e.g., fully online, hybrid, classroom). Given that the Lake Devo website is a unique offering in the area of educational online

role-play, this study explores student response to some of the specific features of the site which distinguish it from other online role-play environments.

## Background

Before settling on the required features for the Lake Devo website, the project team undertook a thorough literature review and investigation of existing practices for online role-play and, in particular, the types of online environments in which these learning activities take place. The findings are summarized here to provide background for the study.

Studies of educational online role-playing describe the use of environments that fall largely into two categories: text-based environments and 3D virtual worlds. Text-based approaches to online role-play typically employ an asynchronous email and discussion board (Freeman & Capper, 1998; Bell, 2001), synchronous chat (Liebowitz, 2003; Phillips, 2005), or a combination of these types of tools, which may be offered through an LMS (Vincent & Shepherd, 1998; McLaughlin & Kirkpatrick, 2004; Bender, 2005; Cornelius, Gordon, & Harris, 2011) or other custom created text-based systems, such as The Forum (Kinder, Fardon, & Yasmeen, 1999) or *ICONS* (Vavrina, 1992; Kaufman, 1998; Starkey & Blake, 2001). One common characteristic of text-based role-play environments is the minimal learning curve for the learners, as well as the instructor, due to existing familiarity with these types of tools (Bender, 2005). In some cases, a customized role-play environment, or virtual situated learning environment (Jones, 2007), also integrates various pre-fabricated media elements such as photos, maps, and videos to help create the sense of a 2D simulated world; examples include Fablusi (Ip, Linser, & Naidu, 2001; Nelson & Blenkin, 2007), and SIMPLE (Barton, McKellar, & Maharg, 2007; Hughes et al., 2008). While media elements are incorporated into these environments, they are typically used for reference and the primary mode of learner interaction remains anchored in text. Some studies have been done regarding the use of 2D “graphical chat” tools (Ingram, Hathorn, & Evans, 2000), but not directly in relation to their support of online role-play.

In addition to text-based environments, online role-play also takes place in 3D virtual environments, which employ sophisticated graphics, allowing learners to represent themselves as avatars in simulated worlds (Gao, Noh, & Koehler, 2009; Morse et al., 2009; Dhaliwal et al., 2007; Jamaludin, Chee, & Ho, 2009). Communication occurs in real time, typically through text chat, animated gestures, movement, and possibly voice. These virtual worlds are engaging, media rich, and include a variety of modes of representation. However, as learning environments they pose several challenges. Dudeney and Ramsay (2009) describe how the learner may become quickly overwhelmed and discouraged by what is known as the “First Hour,” due to the initial high learning curve. Even after learners have become familiar with a virtual world’s environment, challenges may still exist in navigating the user interface, which can be complex and unintuitive (Dudeney & Ramsay, 2009). Furthermore, for instructors,

ensuring that role-play activities work well in the “free format learning experience” (Kluge & Riley, 2008, p. 132) of virtual worlds can be challenging and time consuming. Some studies have indicated that when using 3D virtual worlds for educational purposes, instructors need to ensure that the virtual environment offers enough variety in terms of scenes and objects so that learners do not get bored and frustrated (Finkelstein, 2006); however, at the same time, the environment should not be so appealing as to distract learners from the learning activity (Kluge & Riley, 2008).

Following a review of the types of environments summarized above, the Lake Devo project team turned their attention to considering these environments in the context of a constructivist approach to learning.

## Constructivist Context for Development of Online Role-Playing Environments

Role-play, whether online or in-person, has been acknowledged as a constructivist activity (Wills & MacDougall, 2009), because it employs a learner-centred, experiential and collaborative approach, and incorporates reflective processes as a key strategy (Van Ments, 1999). The online role-play environments discussed in the preceding literature review support many of the goals of a constructivist approach as outlined by Honebein (1996). The following list summarizes these goals.

### Goals for the Design of Constructivist Learning Environments

1. Provide experience with the knowledge construction process.
2. Provide experience in and appreciation for multiple perspectives.
3. Embed learning in realistic and relevant contexts.
4. Encourage ownership and voice in the learning process.
5. Embed learning in social experience.
6. Encourage the use of multiple modes of representation.
7. Encourage self-awareness of the knowledge construction process.

All of the environments reviewed by the Lake Devo project team have learners assume a role and interact with other role-players online. This capability encourages participation in the knowledge construction process and provides exposure to multiple perspectives (Goals 1 and 2). Since the majority of environments allow instructors to provide learners with real-world scenarios, the activities tend to take place within realistic and relevant contexts (Goal 3). Because the instructor often acts as facilitator or moderator and the activities require active participation by all group members, the role-plays are highly collaborative and social forms of learning (Goals 4 and 5). However, with regard to

supporting Goal 6 (the use of multiple modes of representation, e.g., text, graphics, audio) and Goal 7 (encouragement of the self-awareness of the knowledge construction process) the literature reveals some important issues, discussed in detail below, which helped to underpin planning for the Lake Devo project.

## Encouraging Use of Multiple Modes of Representation

As mentioned, the use of multiple modes of representation is a key element of constructivist learning activities such as role-play. Honebein (1996) promotes adoption of additional media such as video and sound to provide richer learning experiences. The environments identified in the literature review represent two extremes with respect to modes of representation—from limited integration of additional media to the use of highly sophisticated multimedia elements. The Lake Devo project team sought to develop an environment that fell somewhere between these two extremes, due to the findings summarized in the following three paragraphs.

Some studies state that traditional online communication tools are poor at supporting interpersonal communication—the development of which is often a key learning objective of role-play activity—because of the limited channels for verbal, aural, and non-verbal cues (Redfern & Naughton, 2002). For example, in the text-based tools described above, visible embodiments of the learners' roles, audible sound, and detectable movement tend to be absent. In a few cases, learners compensated for the lack of visual, verbal, and non-verbal cues by including text descriptions of them (e.g., “Ring, Ring, Ring,” “breaks down in tears”) (Bender, 2005; Nelson & Blenkin, 2007). Although the researchers report that such compensatory measures adequately communicated emotions and attitudes, the absence of multiple modes of representation is not explored.

By contrast, studies in a higher education context that use 3D virtual environments, where visual embodiments of learners' roles are possible (e.g., avatars), have found that realistic visual representations contribute to a feeling of social presence and ultimately a higher level of satisfaction with the learning experience compared to text-only environments (Annetta, Klesath, & Holmes, 2008; Warburton, 2009; Dhaliwal et al., 2007; Jamaludin et al., 2009). Notwithstanding this improved sense of social presence, some virtual environments may present challenges of a different nature. Morse et al. (2009), in their study of role-play within *Second Life*, report that learners derived minimal useful visual data from their own avatar or the avatars of other learners. As a result, learners often misinterpreted gestures and physical positioning of the avatars. Other studies found that avatar's facial expressions in 3D virtual worlds are limited (Peterson, 2006; Bronack et al., 2008)—so much so that learners have resorted to the use of emoticons within the text-based environment of the virtual world's chat tool (Peterson et al., 2007; Bronack et al., 2008).

Further to the findings cited above, it has been argued by some researchers that a high degree of sophistication of visuals, such as 3D avatars, may not be necessary in virtual learning environments (Fabri, Moore, & Hobbs, 2004; Cornelius, Gordon, & Harris, 2011); rather, it is the customization of visuals that is essential (Linser & Ip, 2005, as quoted by Russell & Shepherd, 2010; Robbins-Bell, 2008). Still, detailed studies examining the addition of more simplistic, customizable avatars to supplement text in educational online role-play are lacking. Also lacking are studies regarding the use of sound within virtual worlds as an additional mode of representation in online role-play.

Based on this review, the Lake Devo project team resolved to experiment with offering multiple modes of representation in support of online role-play using tools that would be simple to manipulate.

### Self-Awareness of the Knowledge Construction Process

Honebien (1996) explains that “knowing how we know” (p. 12) is an important outcome of constructivist learning. This requires the creation of opportunities for students to analyze their own construction of knowledge. In the context of role-play activities, this opportunity often takes the form of a debrief. Van Ments (1999) states that debriefing is the most important part of the role-play activity, as it is at this point that behaviours are corrected, lessons are learned, and other possible solutions and outcomes are highlighted. The environments used for role-play activities that take place fully online should support debriefing out of role, within the larger class community (Russell & Shepherd, 2010). While most studies mentioned above acknowledge the importance of the debriefing session, many omit details pertaining to how it is conducted. Some solutions mentioned in the studies comprise a blended approach, incorporating some face-to-face interactions (Bell 2001; McLaughlin & Kirkpatrick, 2004; Hrastinski & Watson, 2009). Among the studies that do provide details are some that indicate that group members’ experiences of the online role-play form the basis of the debrief (Vincent & Shepherd, 1998; Phillips, 2005; Nelson & Blenkin, 2007). In other cases, the entire class attends a live online role-play session or follows an asynchronous discussion board thread and observes as the role-play unfolds (Liebowitz, 2003; Bender, 2005).

Of particular note are the studies indicating that artifacts (lasting, retrievable, and accurate records) of the online role-plays are used for a debrief (Bender, 2005). In studying games, simulations, and virtual worlds, Aldrich (2009) states that using an artifact is advantageous because if the activity cannot be witnessed by others in real time then the artifact can be viewed and shared at a later date. In addition to providing a way to retrieve a learner’s or group’s work well beyond the activity, the artifact could be considered a type of learner presentation and may therefore also reinforce the feeling of learner ownership. Lastly, it can serve as the basis of assessment (Aldrich, 2009). In those studies of online role-play which indicate the use of some sort of artifact, it appears most often in the form of a chat transcript, which is distributed among all class members (Bender, 2005).

Beyond the text-based artifact (such as a chat transcript) is the notion, described by Miao et al. (2000), of a “visually structured knowledge representation method” that provides learners the opportunity to “build a coherent representation of their common knowledge” (p. 306). This visual representation functions as a “group memory” and allowing learners access to it gives them the opportunity to “negotiate and explore the information in the shared artifact” (Miao et al., 2000). Miao et al. (2000) specifically examine the use of shared artifacts for the presentation of complex online problem-based research and learning. Where online role-play is concerned, the concept of a visual shared artifact is mostly absent, aside from the labour-intensive possibility in virtual worlds of media elements manually added to the chat transcript (e.g., screen shots, videos) (Morse et al., 2009). A visual shared artifact as an integrated element of a given role-play tool does not appear to be currently or easily available. Furthermore, none of the existing studies of online role-play tools describe in detail how an artifact might engage learners, be easily sharable among all peers, or be combined with a discussion space for peer exchange and reflection.

In summary, the Lake Devo team observed through their review of the literature, that an environment which allowed for multiple modes of representation, along with an integrated debrief area incorporating a visual artifact, might support online role-play in a manner not yet offered in existing online role-play environments.

## Focus of this Study

Given the request presented by the instructor, and the findings of the Lake Devo team’s review of online role-play environments, the project team set out to develop an environment that offered a middle ground between text-only online role-play environments and highly complex 3D virtual environments. They deliberately chose not to design a fully realistic world in which to interact, but rather an environment for role-play dialogue that would offer added channels of expression to support interpersonal communication, as well as an integrated debrief area. With these goals in mind, the project team identified the following enquiries as their focus when conducting an assessment of the Lake Devo pilot.

Do the following elements, which are present in the Lake Devo website, support and engage learners in online role-play activity in a manner not offered in text-only or 3D virtual environments?

- Simple visual and audio modes of representation such as avatars, background images, and sound effects
- An integrated debrief area that includes a shareable, multimedia artifact and forum for discussion

A brief description of the Lake Devo role-play environment is provided below to provide additional context for the study.



## Lake Devo Description

Lake Devo is a web-based application, accessible at [lakedevo.ryerson.ca](http://lakedevo.ryerson.ca), used by Ryerson University instructors to support online role-play assignments, which typically include identified learning outcomes associated with interpersonal communication and negotiation skills. The site affords learners the ability to undertake preparatory work asynchronously prior to interacting synchronously for the purposes of the role-play activity. Once the role-play activity is complete, the proceedings of the role-play may be published in the form of a presentation, or artifact, referred to in Lake Devo as a movie (see Figure 1). (Note: The site has been upgraded since the time of this study and, when accessed with the above link, will appear differently from the screen shots below.)

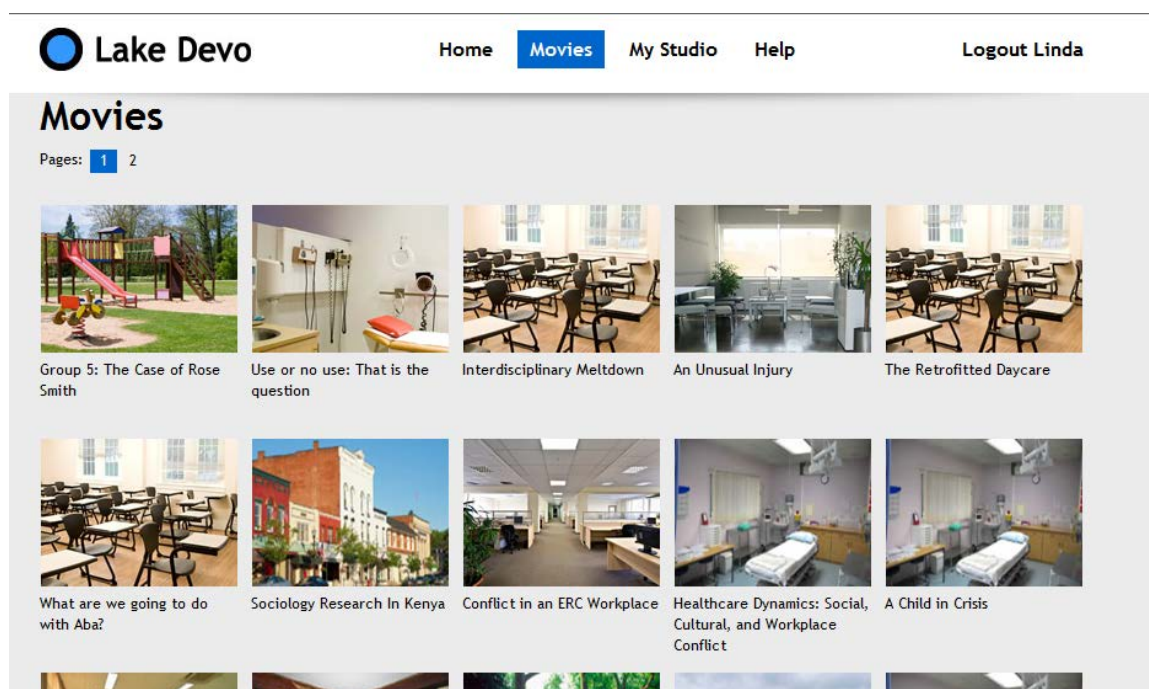

Figure 1. Screenshot of the Lake Devo Movies page.

In order for learners to participate in a role-play exercise, a Lake Devo Community must be created for each cohort. This takes place when class lists are provided by instructors to the Lake Devo team at DES for entry in the Lake Devo database. Once a class is entered into the database as a Community, the learners are organized into role-play groups (either randomized or instructor-specified) and a group leader is identified. Learners are issued passwords to access their project in the role-play environment.

Before the live role-play activity, each group member creates a visual representation, or avatar, of his or her role-play character using the Character Creation tool, which allows customization in form (see Figure 2). Learners make selections from a menu of physical attributes such as skin tone, hair colour and style, clothing colour, and facial features.



Also before the live role-play, group leaders set up background scenes (choosing from a library of images) in which the role-play will take place. For characters and scenes, names and descriptions can be added to provide context.



Figure 2. Screenshot of the Lake Devo Character Creation tool.

Once avatars have been created, the group must agree on a time to meet live online to role-play synchronously. The group members participate as their avatars in a spontaneous dialogue, which forms a “script.” Learners see their fellow role-players posting in real time (Figure 3). To enhance participants’ ability to express emotions, graphics representing facial expressions can be selected with each dialogue entry (Figure 4). Text during the scripting can be entered as speech, thought, or action. Learners may select sounds (such as coughing, whistling, laughter, footsteps, a doorbell, a phone ringing, etc.) to insert in the script from a built-in library. The sound effects are divided into menus of character generated and ambient sounds. All group members are able to see and hear these additional audio elements, when they are inserted into the dialogue by an individual member during the live role-play. In addition, a Backstage Group Chat area assists learners in planning the role-play and discussing logistics as the role-play unfolds.

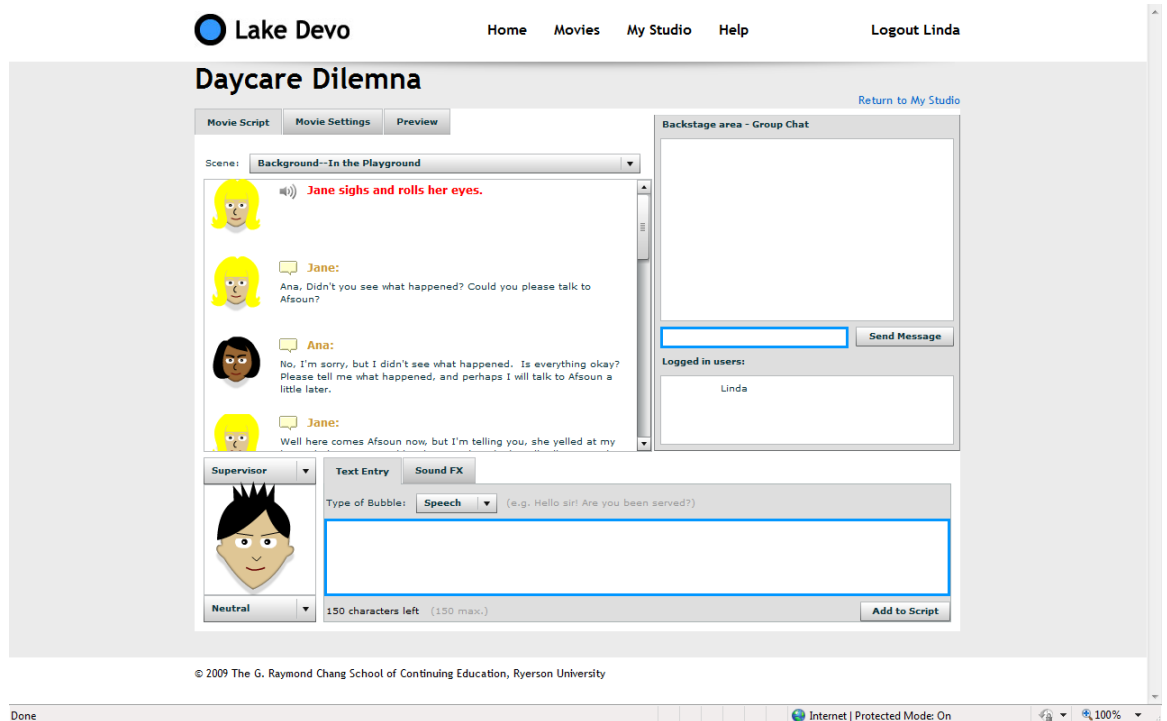

Figure 3. Screenshot of the Lake Devo Script Building tool.

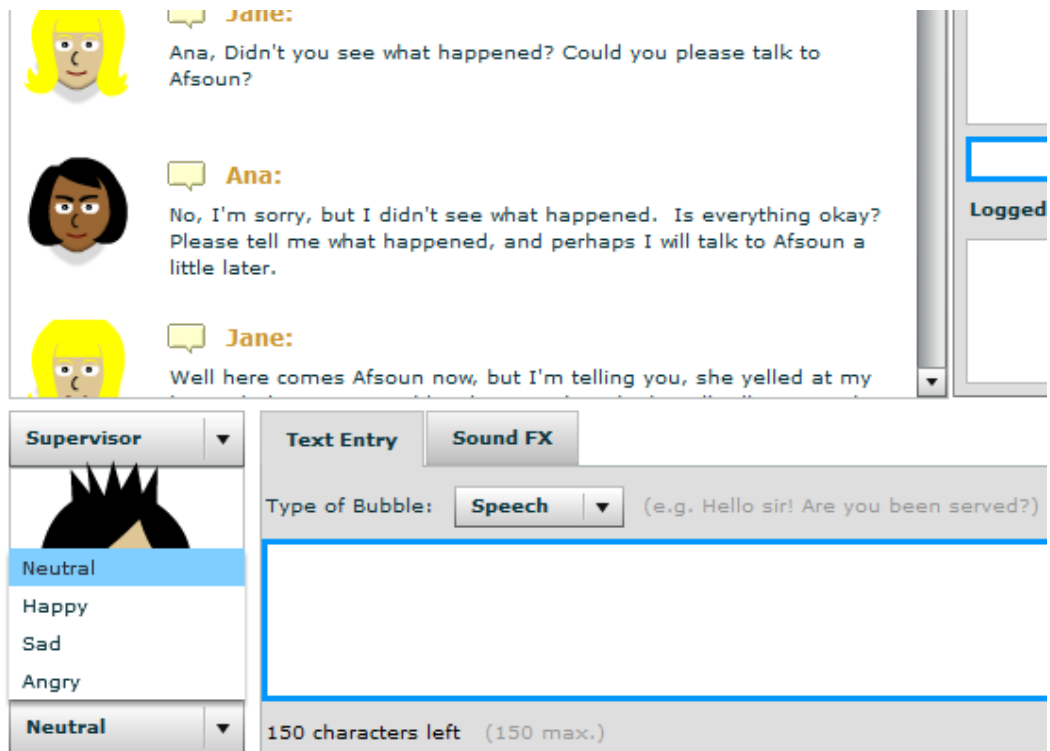
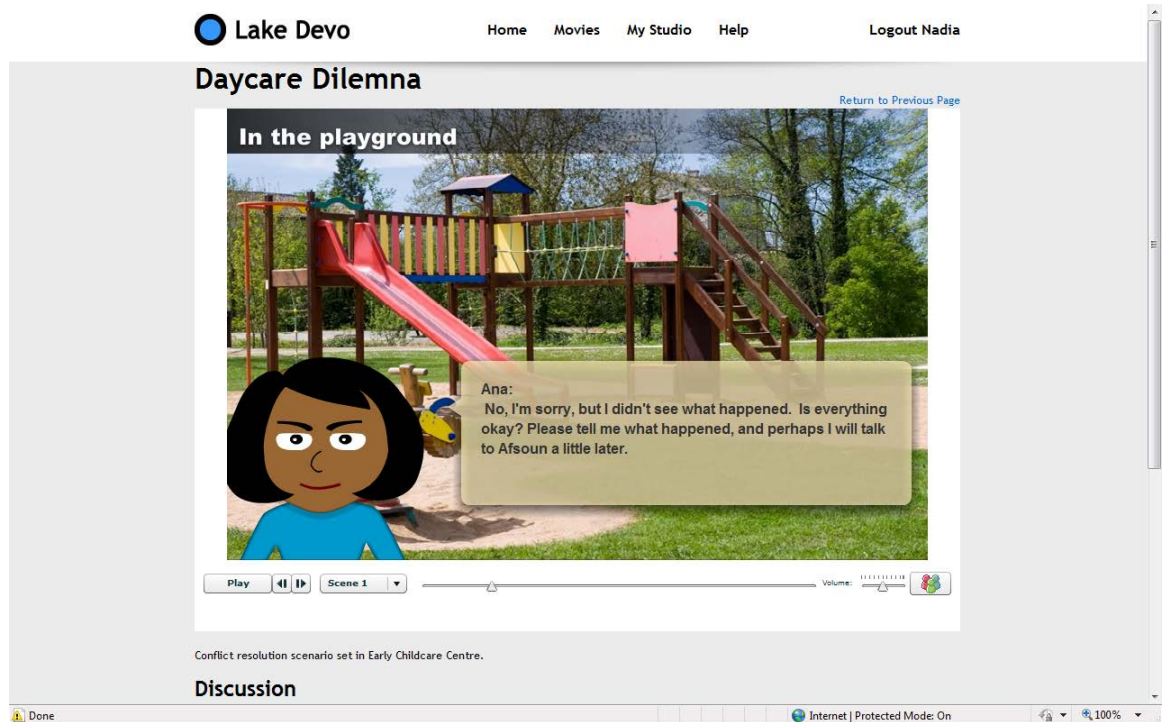

Figure 4. Screenshot of the Lake Devo Emotional Expression Selector tool.

The role-play dialogue is automatically saved, but each learner may edit his or her character's dialogue after the live role-play activity. Once a group has finalized their role-play, they publish it to their Lake Devo Community list in the form of a 2D narrative movie. Because members of the community can easily view role-play movies, the movie format allows all to participate in the debriefing, which occurs in a discussion area below each movie (Figure 5).



Conflict resolution scenario set in Early Childcare Centre.

### Discussion

**Linda wrote:**

I didn't think the supervisor was very supportive of Anna. She could have coached her.

Sep 2 2010 4:09PM | 0 replies | [Reply to Linda](#)

**Nadia wrote:**

Yes, especially since two co-workers phoned in sick and Ana was there by herself. The supervisor should have been there the whole time.

Sep 17 2010 4:36PM | 0 replies | [Reply to ...](#)

[Add New Comment](#)

Figure 5. Screenshot of the Lake Devo Role-play Debrief area.

## Method

An action research methodology was taken when creating Lake Devo, as well as when analyzing the results of the pilot project. Given its collaborative and participatory nature, this methodology aligned well with the constructivist approach of the team. The project team moved ahead with their development of the Lake Devo website with, what Kember (1998) phrases as “an avowed intention of improving their practice,” through trial, evaluation, and refinement (p. 53).

Lomax (2007) defines action research as action for improvement, done by oneself, on one's own practice, democratically, to generate theory, in a critical, iterative manner. Lomax (2007) further specifies that action research should be validated by peers and presented for consideration to other professionals, policymakers, users, and academics. In keeping with these characteristics, the Lake Devo project team sought to improve practice at Ryerson in delivering role-play in online learning. The team enlisted input from instructors, students, instructional designers, and web developers on their design for the Lake Devo role-play environment. Upon piloting the use of the Lake Devo website by students, the team developed an online survey to gather feedback on Lake Devo. The study was approved by the Ryerson University Research Ethics Board and the results of the survey are reported here.

As mentioned in the Introduction, the subjects of the study were participants in the online course, “Conflict Resolution and Dispute Negotiation” (CINT905). The participants comprised members of the winter 2010 and winter 2011 fully online offerings of the course through The Chang School at Ryerson. In each of these offerings of the course, the Lake Devo online role-play environment was provided for use for an assigned role-play activity. Once students had completed the online role-play and debrief activities, an announcement was posted on the course homepage inviting learners to participate in the 37 item online questionnaire. The questionnaire included a mix of question types, including a four-point Likert agreement scale, yes or no questions, and open-ended questions. Learners were asked to assess their experience with Lake Devo in the following categories: visualization of character and situational setting; level of involvement in creation and viewing of movies; use of communication tools; and personal satisfaction with the experience. At the end of each category of questions, learners were invited to share further comments. These categories, and the questions associated with them, were formulated to measure the extent to which some of the distinct features of the Lake Devo online role-play environment (i.e., visual and audio elements, an integrated debrief area) supported online role-play activity (see Focus of this Study).

One hundred and sixteen learners were invited to participate. Fifty-four percent ( $n = 61$ ) responded. The majority of the respondents were female (90%) and the age range, among those under 54 years, was relatively evenly distributed (see Table 1).

Table 1

*Range of Age of Survey Participants*

Age range	Percentage
Under 24 years	38%
25–34 years	27%
35–54 years	31%
Over 50 years	5%

## Results

### Visual Representation

(Note: Throughout the questionnaire and results, avatars are referred to as characters, in keeping with the nomenclature of the Lake Devo website.)

Overall, elements of visual representation on the Lake Devo website received extremely positive feedback from the pilot groups, as demonstrated below by the results presented in Table 2. On the Likert agreement scale, learners reported that the ability to represent the character visually helped in expression (95%) and was enjoyable (93%). There was also high agreement that the use of graphics assisted with the expression of emotion (83%). Ninety-eight percent agreed that character creation was easy, and the majority liked the look of the character (80%). A feeling of ownership in creating the character had an 86% agreement rating. Eighty-eight percent of the learners reported that they identified with the character (see Table 2).

Table 2

*Ease of Visual Representation of Character and Backgrounds*

Students were asked to rate the following statements:	Agree %	Disagree %
The graphics for emotional expression helped me express emotions of my character that would have been difficult in the online environment.	83	17
Being able to represent my character visually helped me express aspects such as personality or physical traits that would have otherwise been difficult in the online environment.	95	5
Creating my own character was enjoyable.	93	7
Creating my own character was easy.	98	2
I like the look of the character I can create.	80	20
Being able to create a visual representation of my character helped me identify with the character I role-played.	88	12
Being able to create a visual representation of my character gives me a sense of ownership.	86	14
The ability to add backgrounds was important to me in setting the scene of the conflict scenario.	96	4

After rating the statements above, learners were provided with the opportunity to respond to the following request: “Please enter any comments about character creation.” Learner comments in this category mentioned the ease of use of the application. In the words of one learner, “I thought creating my own character was an interesting way to represent how I would want the character to look. It was easy.”

Another learner commented that the creation of characters and backgrounds was “fun and interactive” and “worth spending the time to figure it out.”

The ability to customize visual elements also drew positive comments:

The character creation ... allowed for cultural additions, which was important to our conflict course when dealing with multicultural barriers.

I thought it was really neat that we had the opportunity to make our own characters. It allowed a lot more personalization than I thought possible in an online course.

In their comments, learners identified a need for expanded options among the visual elements of the application. For example, in one learner’s words,

There should be more facial features, clothing, and sound effects available when creating your character. Also, there should be more scene backgrounds; sometimes you are limited to choosing certain visuals that are not 100% correlated to your character or theme.

Similar feedback included:

A wider choice of character emotions would have been more useful to portray the atmosphere (e.g., surprised, confused).

I felt as though many of the characters in our group looked very similar, therefore a little confusing. It would be nice to have more options for hair, eyes, noses, etc.

My character was of a nurse. There wasn't any specific attire that represented me as a nurse, therefore, I still had to wear the normal casual clothes and specifically had to say I was a nurse in order for the viewers to understand.

## Sound Effects

Again on the Likert scale, there was high agreement with the statement that the ability to add sound effects helped learners express aspects of the character that would have otherwise been difficult in the online environment (87%). In addition, when asked to rate the importance of using sound effects to set the scene of the conflict, learners valued ambient sound effects (88%) (see Table 3).

Table 3

### *Sound Effects*

Students were asked to rate the following statements:	Agree %	Disagree %
The ability to include sound effects produced by my character helped me to express aspects of the character that would have been otherwise difficult in the online environment.	87	13
The ability to include ambient sound effects was important to me in setting the scene of the conflict scenario.	88	13



## Movie Creation and Viewing

Ratings of statements with respect to learner involvement in movie creation and viewing showed that the majority of the respondents agreed that creating the script was easy (79%) and enjoyable (84%). Eighty-eight percent agreed that watching the movies from the other groups helped them understand the conflict scenario (see Table 4).

Table 4

### *Involvement in Movie Creation and Viewing*

Students were asked to rate the following statements:	Agree %	Disagree %
Creating the script was easy.	79	21
Creating a script was enjoyable.	84	16
Creating a movie helped me express important nuances of the conflict scenario that would have been difficult in the online environment.	97	3
I enjoyed watching movies from other groups.	84	16
When watching movies from other groups, the movie format (i.e., visuals) helped me to understand the conflict scenario.	88	12

After rating the statements above, learners were provided with the opportunity to respond to the following request: “Please enter any comments about movie creation and viewing.” The comments regarding the experience of movie creation echoed the Likert ratings, with statements such as “I enjoyed the role-play and found it to be well thought out” and “The [backstage] chat feature was very helpful in putting the script together.”

The mechanics of viewing the final movies presented some challenges, as was evidenced by comments such as “Sometimes I felt that the movies could have had a faster pace. I felt that I waited awhile until the next character spoke, etc.”

Suggestions for further improvement were offered, including “Creation was ok, viewing it would be great if the movie actually read the script and the character had actual voices.”

Other ideas regarding the movie compilation and viewing included, “Though the backgrounds were nice, the use of props and more realistic characters could have enhanced the movie's appeal.”

Additionally, one learner proposed, “Character movement and seeing more than one character at a time.”

## Learning Community and Engagement

According to the ratings for statements pertaining to the notion of a learning community, and to learner engagement, creating a movie resulted in feelings of personal accomplishment (87%) and a sense of community with group members (83%). Many (82%) incorporated elements to entertain and influence movie viewers. When creating a character, 73% agreed that they were influenced by how their classmates might perceive their character. Ninety percent agreed that peer comments and feedback on the group's movie stimulated dialogue (see Table 5).

Table 5

### *Role of Learning Community*

Students were asked to rate the following statements :	Agree %	Disagree %
I felt a sense of accomplishment in creating the movie with my group.	87	13
Creating a movie helped me create a sense of community with my group members.	83	17
When creating the script, we incorporated elements to entertain and influence movie viewers.	82	18
When creating my character, I took into account how s/he might be perceived by my classmates.	73	27
Peer comments and feedback on my group's movie stimulated dialogue.	90	10
My groups was able to work together easily using Lake Devo.	79	21
The role of Group Leader was essential to the group activity.	82	18

Table 6

### *Synchronous Collaboration*

Students were asked to respond with a Yes or a No to the following statements:	Yes	No
To create the script, members of my group agreed on a time to log in to Lake Devo.	79	21
My group created the script spontaneously, with little rehearsal of the actual dialogue.	80	20

When invited to enter any comments about working in a group and about the learning community, many learners indicated that they enjoyed the group work experience facilitated by the Lake Devo application. Their comments included:

I found this exercise very enjoyable because of the teamwork involved, and the novelty of the method.

This was a fun and exciting exercise that added to a group learning activity which was the conflict focus of this course!

Interesting and unique way to facilitate online group learning. Some improvements could be made, but good program overall.

The majority of respondents agreed that their groups were able to arrange scripting collaboration in Lake Devo and that they authentically and spontaneously role-played (see Table 6). Nonetheless, as with many collaborative activities, some feedback was received regarding the challenges of working as a group. Some of these comments included:

It was a little frustrating communicating in Lake Devo, I found possibly just because you are working with a group of people rather than just one other person.

It was difficult to have all members meet online at the same time. The leader option was frustrating because we felt as though we couldn't accomplish very much without the group leader. It would be beneficial to free up some of the roles only the leader was allowed to do.

## Discussion

As stated earlier, the Lake Devo project team set out to enhance the practice of online role-play at Ryerson through the development of a new online role-play environment. Based on the review of environments in use at the time, they deliberately designed an easy to use website, employing simple avatars, background images, and sound effects to provide multiple modes of representation in support of role-play activities. Additionally, the design allowed for the production of a movie artifact, available for review in an integrated debrief area. These design features were identified as critical to supporting the constructivist goals of role-play activity. As part of the action research approach to the project, the team collected student feedback through an online questionnaire, which produced promising findings with respect to modes of representation and the use of the movie artifact to support knowledge of the learning process.

## Simple Avatars, Facial Expressions, Backgrounds, and Sound Effects as Means of Encouraging Multiple Modes of Representation

The findings of the online questionnaire supported the idea that even simple avatars and other visual and audio elements, such as those available in the Lake Devo role-play environment, can effectively enhance and support online role-play activity. Two themes emerged from the comments of the survey participants.

Firstly, as proposed by Fabri, Moore, and Hobbs (2004) and Cornelius, Gordon, and Harris (2011), a high degree of visual realism may not be necessary in the online learning environment to engage learners in role-play activity. Based on their studies of computer games, Reeves and Nass (1996, cited in Westera, 2011) suggest that experiences which draw on limited representational and technological efforts can provoke true interpersonal responses. Such responses are clearly important in role-plays geared towards conflict resolution and negotiation. Herrington, Reeves, and Oliver (2007) examined the impact of realism in online learning environments and found that “the ‘cognitive realism’ of the task is of greater importance than the reality of the task or its realistic simulation” (p. 94). Learner reactions to the pilot of the Lake Devo application echo the research in this area. As described earlier, Lake Devo was not designed to be a fully realistic world in which to interact; rather, it offers added channels of expression to support interpersonal communication. Although one learner did mention that more realistic backgrounds and props might have enhanced the movie, the overwhelming majority of participants found the simple avatars, background, and sound effects that were available during the role-play and used in the final movie to be easy to implement and helpful to their role-play activity. In the words of one learner, “The characters were pretty simplistic and I think this helps to concentrate on the actual role-play and not so much on the creation of the character.”

Secondly, as put forward by Linser and Ip (2005), as cited by Russell and Shepherd (2010) and Robbins-Bell (2008), choice and customization for audio-visual elements in the application are highly valued. Redfern and Naughton (2002) suggest that avatars that are “appropriately detailed and customizable” provide a richness of expression and personality (p. 206). This notion is supported by learner comments in the survey, such as

There should be more facial features, clothing, and sound effects available when creating your character. Also, there should be more scene backgrounds; sometimes you are limited to choosing certain visuals that are not 100% correlated to your character or theme.

Redfern and Naughton (2002) claim further that customizable avatars generate interest for learners in each other’s characters. As one Lake Devo participant observed,

A wider choice of character emotions would have been more useful to portray the atmosphere (e.g., surprised, confused, etc.).

I felt as though many of the characters in our group looked very similar, therefore a little confusing. It would be nice to have more options for hair, eyes, noses, etc.

The findings of the survey, along with the literature, point to the value of simple, easy to use avatars with options for facial expressions, sound effects, and scene backgrounds, but help to underscore that greater choice in these elements would further support the role-play activity.

### Movie Artifact and Associated Asynchronous Discussion Area for Debrief

While the first area of study for this paper took into account the effectiveness of various audio-visual elements of the Lake Devo site, the second question examines the role of the multimedia component (i.e., the movie) functioning as a basis for the debrief in the associated discussion area.

Earlier, digital artifacts were outlined as beneficial in that they represent a way to record the learning event, can be shared among peers, and used for assessment purposes. More specific to visual artifacts, as opposed to text-based versions only, Perry and Edwards (2010), in their discussion of artistic pedagogical technologies, suggest that learning activities that are founded in the arts (including visual) may facilitate more authentic and meaningful social interaction between learners in an online environment. In Lake Devo, the movie as a multimedia artifact, coupled with the integrated discussion and debrief area, is especially supportive of the constructivist nature of any role-play activity. Van Ments (1999) states that there are obvious advantages to creating an audio or video record of what occurred in a role-play, including the fact that it affords learners the opportunity to study their own performance while out of role. Although the visual format in Lake Devo differs from the recording of a live performance as described by Van Ments, it can be argued that the movie plays an important role in scaffolding students' self-awareness of the knowledge construction process, by allowing for thoughtful review of the proceedings once out of role. Eighty-eight percent of participants in the Lake Devo pilot agreed that watching movies from other groups helped them to understand the conflict scenario. Furthermore, 90% of Lake Devo pilot participants agreed that peer comments and feedback on their group's movie stimulated dialogue. While not addressed in this survey, the movie, as well as the dialogue resulting from it, could easily form the basis of learner assessment.

## Limitations

A limitation of this pilot study was the issue of technical difficulties that learners encountered, which, although resolved quickly by the DES technical support team, added frustration to the learning experience. A temporary error generated by the movie player caused one group to move their debriefing to the Blackboard LMS discussion boards. This perhaps occurred because learners and instructors were accessing the system outside of regular business hours and the technical team was unavailable to provide immediate assistance. It is believed that some learners encountered problems viewing movies, but, perhaps because they found a way to work around the problem, it was not reported until learners had the opportunity to complete the questionnaire. One participant indicated in the survey, “I had a hard time viewing the movies. I always seemed to get an error and could never view the whole movie. I had to use the arrows to fully watch the movie so no errors would come up.”

## Implementing Findings

Based on survey comments, the DES team has already initiated changes to the application to include more visual options for character appearance and emotions. Also the artistic style has been updated to increase the versatility in giving a unique look to learners’ characters and movies based on the options they choose. The Leader role may now be exchanged among group members. The debrief area remains similar to the pilot version of the application, but further data will be collected to ensure that the design of this area optimizes the possibility of learner participation.

## Recommendations and Further Research

While visual and audio options within the Lake Devo application were well received, not all aspects pertaining to modes of representation, which might impact the role-play activity and final movie, were addressed. Areas for further study include evaluating whether additional features to Lake Devo would add value, such as voice capability, enabling variety in character placement on movie backgrounds, and the ability to display props or multiple characters together on screen.

With respect to the integrated debrief area, further research is needed on the quality of postings to the discussion, as well as factors to encourage increased or optimal participation in the debrief activity.

As this study was limited to the use of the Lake Devo website in the context of only one course, additional research into the use of the site for role-play activities in other disciplines and in support of varying learning objectives may also be of value. Further testing of the Lake Devo site with a broader sampling of students certainly merits consideration given that the respondents in this study were predominantly female.

## Conclusion

A review of the current literature, together with online survey results, suggest that the Lake Devo website provides a unique alternative to text-based and/or 3D virtual worlds as an environment that supports online role-play. The interface is intuitive and easy to use for both learners and instructors. Through the use of simple avatars, a selection of emotional expressions, and audio features, learners have the opportunity to convey non-verbal cues, which are critical to interpersonal interaction. All of these features, as supplements to the text elements, enhance the learner experience and help to support the constructivist principle of encouraging the use of multiple modes of representation. Lake Devo movies, as artifacts, along with the integrated debrief area provide an opportunity for self-awareness of the knowledge construction process. For the Lake Devo project team, whose practice is anchored in a constructivist approach, the study has encouraged a further iteration of the website, which they will continue to review, in their efforts towards continuous improvement. For practitioners beyond the Lake Devo project team and the Ryerson context, the Lake Devo website provides an example of an online role-play environment that offers alternatives to text-based and/or 3D virtual worlds.



## References

- Aldrich, C. (2009). *Learning online with games, simulations, and virtual worlds: Strategies for online instruction*. San Francisco: Jossey Bass.
- Annetta, L., Klesath, M., & Holmes, S. (2008). V-learning: How gaming and avatars are engaging online students. *Innovate: Journal of Online Education*, 4(3).
- Barton, K., McKellar, P., & Maharg, P. (2007). Authentic fictions: Simulation, professionalism and legal learning. *Clinical Law Review*, 14(1), 143–93.
- Bell, M. (2001). Online role-play: Anonymity, engagement, and risk. *Educational Media International*, 38(4), 251–260.
- Bender, T. (2005). Role-playing in online education: A teaching tool to enhance student engagement and sustained learning. *Innovate: Journal of Online Education*, 1(4).
- Bronack, C., Cheney, A., Riedl, R., & Tashner, J. (2008). Designing virtual worlds to facilitate meaningful communication: Issues, considerations, and lessons learned. *Technical Communication*, 55(3), 261–269.
- Cornelius, S., Gordon C., & Harris, M. (2011). Role engagement and anonymity in synchronous online role-play. *International Review of Research in Open and Distance Learning*, 12(5), 57–73.
- Dhaliwal, K., Gillies, M., O'Connor, J., Oldroyd, A., Robertson, D., & Zhang, L. (2007). eDrama: Facilitating online role-play using emotionally expressive avatars. In P. Olivier & R. Aylett (Eds.), *Proceedings of the AISB workshop on language, speech, and gesture for expressive characters*. Leeds, UK: The Society for the Study of Artificial Intelligence and the Simulation of Behaviour.
- Dudeney, G., & Ramsay, H. (2009). Overcoming the entry barriers to *Second Life* in higher education. In C. Wankel and J. Kingsley (Eds.), *Higher education in virtual worlds: Teaching and learning in Second Life* (pp. 11–28). Bingley, UK: Emerald Group Publishing Limited.
- Fabri, M., Moore D., & Hobbs D. (2004). Mediating the expression of emotion in educational collaborative virtual environments: An experimental study. *Virtual Reality*, 7, 66–81.
- Feinstein, A., Mann, S., & Corsun, D. (2002). Charting the experiential territory: Clarifying definitions and uses of computer simulations, games, and role-play. *Journal of Management Development*, 21(10), 732–744.

- Finkelstein, J. (2006). *Learning in real time: Synchronous teaching and learning online*. San Francisco: Jossey-Bass.
- Freeman, M., & Capper, J. (1998). *An anonymous asynchronous web-based role-play*. Retrieved from <http://www.ascilite.org.au/conferences/wollongong98/asc98-pdf/freemancapper.pdf>
- Gao, F., Noh, J., & Koehler, M. (2009) Comparing role-playing activities in *Second Life* and face-to-face environments. *Journal of Interactive Learning Research*, 20(4), 423–443.
- Herrington, J., Reeves, T.C., & Oliver, R. (2007) Immersive learning technologies: Realism and online authentic learning. *Journal of Computing in Higher Education*, 19(1), 65–84.
- Honebein, P. (1996). Seven goals for the design of constructivist learning environments. In P.G. Wilson (Ed.), *Constructivist learning environments: Case studies in instructional design* (pp. 11–24). Englewood Cliffs, NJ: Educational Technology Publications.
- Hrastinski, S., & Watson, J. (2009). Designing and evaluating an online role-play in conflict management. *Campus-Wide Information Systems*, 26(4), 287–297.
- Hughes, M., Gould, H., McKellar, P., Marharg, P., & Nicol, E. (2008), *SIMulated professional learning environment (SIMPLE) programme final report*. Glasgow: University of Strathclyde.
- Ingram, A., Hathorn, L., & Evans, A. (2000). Beyond chat on the internet. *Computers and Education*, 35, 21–35.
- Ip, A., Linser, R., & Naidu, S. (2001). *Simulated worlds: Rapid generation of web-based role-play*. Retrieved from <http://ausweb.scu.edu.au/aw01/papers/refereed/ip/>.
- Jamaludin, A., Chee, Y., & Ho, C. (2009). Fostering argumentative knowledge construction through enactive role-play in *Second Life*. *Computers & Education*, 53(2), 317–329.
- Jones, S. (2007). Adding value to online role-plays: Virtual situated learning environments. *ICT: Providing choices for learners and learning*, Proceedings Ascilite Singapore, 468–477.
- Kaufman, J. (1998). Using simulation as a tool to teach about international negotiation. *International Negotiation A Journal of Theory and Practice*, 3(1), 59–75.

- Kember, D. (1998). Action research: Towards an alternative framework for educational development. *Distance Education*, 19(1), 43–63.
- Kinder, J., Fardon, M., & Yasmeen, S. (1999). Offline or online? A simulation exercise in a first-year international politics unit. In J. Winn (Ed.), *Australian society for computers in learning in tertiary education conference*. Brisbane, Australia: Teaching and Learning Support Services, Queensland University of Technology.
- Kluge, S., & Riley, L. (2008). Teaching in virtual worlds: Opportunities and challenges. *Issues in Informing Science & Information Technology*, 5, 127–135.
- Lane, L. M. (2008). Toolbox or trap? Course management systems and pedagogy. *Educause Quarterly*, 31(2), 4.
- Levitt, C., & Adelman D. (2010). Role-playing in nursing theory: Engaging online students. *Journal of Nursing Education*, 49(4), 229–232.
- Liebowitz, J. (2003). Teach people skills totally online? *College Teaching*, 51(3), 82–85.
- Lomax, P. (2007). Action research. In A. Briggs & M. Coleman (Eds.), *Research methods in educational leadership and management* (pp. 156–172). London: SAGE Publications Ltd.
- McLaughlin, R., & Kirkpatrick, D. (2004). Online role-play: Design for active learning. *European Journal of Engineering Education*, 29(4), 477–490.
- Miao, M., Holst, S., Holmer, T., Fleschutz, J., & Zentel, P. (2000). An activity-oriented approach to visually structured knowledge epresentation for problem-based learning in virtual learning environments. In R. Dieng, A. Giboin, L. Karsenty, & G. De Michelis (Eds.), *Designing cooperative systems: The use of theories and models* (pp. 303–318). Amsterdam, Netherlands: IOS Press.
- Morse, S., Littleton, F., Macleod, M., & Ewins, R. (2009). The theatre of performance appraisal: Role-play in *Second Life*. In C. Wankel & J. Kingsley (Eds.), *Higher education in virtual worlds: Teaching and learning in Second Life* (pp. 181–201). Bingley, UK: Emerald Group Publishing Limited.
- Moser, F. Z. (2007). Faculty adoption of educational technology. *EDUCAUSE Quarterly*, 30(1), 66.
- Nelson, D., & Blenkin, C. (2007). The power of online role-play simulations: Technology in nursing education. *International Journal of Nursing Education Scholarship*, 4(1), 1–12.
- Perry, B., & Edwards, M. (2010). Creating a culture of community in the online classroom using artistic pedagogical technologies. In B. Veletsianos (Ed.),

- Emerging technologies in distance education* (pp. 129–152). Athabasca, AB: Athabasca University Press.
- Peterson, M. (2006). Learner interaction management in an avatar and chat-based virtual world. *Computer Assisted Language and Learning*, 19(1), 79–103.
- Phillips, J. (2005). Chat role-play as an online learning strategy. *Journal of Nursing Education*, 44(1), p. 43.
- Redfern, R., & Naughton, N. (2002). Collaborative virtual environments to support communication and community in internet-based distance education. *Journal of Information Technology Education*, 1(3), 201–211.
- Robbins-Bell, S. (2008). Higher education as virtual conversation. *EDUCAUSE Review*, 43(5), 24–35.
- Russell, C., & Shepherd, J. (2010). Online role-play environments for higher education. *British Journal of Educational Technology*, 41(6), 992–1002.
- Starkey, B., & Blake, L. (2001). Simulation in international relations education. *Simulation & Gaming*, 32(4), 537–551.
- Van Ments, M. (1999). *The effective use of role-play: A handbook for teachers and trainers* (2<sup>nd</sup> ed.). London: Kogan Page Ltd.
- Vavrina, V. (1992). From Poughkeepsie to Peoria to the Persian Gulf: A novice's *ICONS* odyssey. *PS: Political Science and Politics*, 25(4), 700–702.
- Vincent, A., & Shepherd, J. (1998). Experiences in teaching Middle East politics via internet-based role-play simulations. *Journal of Interactive Media in Education*, 98(11).
- Warburton, S. (2009). *Second Life* in higher education: Assessing the potential for and the barriers to deploying virtual worlds in learning and teaching. *British Journal of Educational Technology*, 40(3), 414–426.
- Westera, W. (2011). On the changing nature of learning context: Anticipating the virtual extensions of the world. *Journal of Educational Technology & Society*, 14(2), 201–212.
- Wills, S., & McDougall, A. (2009). Reusability of online role play as learning objects or learning designs. In L. Lockyer, S. Bennett, S. Agostinho & B. Harper (Eds.), *Handbook of research on learning design and learning objects: Issues, applications and technologies* (Vol. 2, pp. 761–776). Hershey, PA: Information Science Reference.

Athabasca University 



## Using Wikis for Online Group Projects: Student and Tutor Perspectives



Karen Kear, Helen Donelan, and Judith Williams  
The Open University, United Kingdom

### Abstract

This paper presents a study of the use of wikis to support online group projects in two courses at the UK Open University. The research aimed to investigate the effectiveness of a wiki in supporting (i) student collaboration and (ii) tutors' marking of the students' collaborative work. The paper uses the main factors previously identified by the technology acceptance model (TAM) as a starting point to examine and discuss the experiences of these two very different user groups: students and tutors. Data was gathered from students via a survey and from tutors via a range of methods. The findings suggest that, when used in tandem with an online forum, the wiki was a valuable tool for groups of students developing a shared resource. As previous studies using the TAM have shown, usefulness and ease of use were both important to students' acceptance of the wiki. However, the use of a wiki in this context was less well-received by tutors, because it led to an increase in their workload in assessing the quality of students' collaborative processes. It was possible to reduce the tutor workload by introducing a greater degree of structure in the students' tasks. We conclude that when introducing collaborative technologies to support assessed group projects, the perceptions and needs of both students and tutors should be carefully considered.

**Keywords:** Wikis; collaboration; online learning; group projects; technology acceptance model

## Introduction

Group projects can help students to learn collaboratively about course topics and present their knowledge creatively. Group work can also be valuable for developing students' employability skills such as planning and interpersonal communication. However, successfully integrating group work into courses has its challenges, particularly in a distance learning or e-learning context. This paper discusses the implementation of a group project in a distance learning setting, and the role of communication technologies in supporting this implementation. The paper presents research findings on an initiative, which took place over several years, where wikis were used for online group projects in a course on information and communication technologies at the UK Open University. The aims of this initiative were to enable genuine student collaboration online and also to support tutors in the fair and efficient marking of the group projects.

The paper considers the students' and tutors' acceptance (or otherwise) of wikis, using the main factors identified by the technology acceptance model (TAM) as a theoretical basis (Davis, 1989). The TAM relates users' acceptance of new technologies to two primary factors: the usefulness and usability of the technologies. As the paper demonstrates, a user's judgement of these aspects depends on the tasks they need to carry out. In the initiative reported here, two sets of users were required to carry out different tasks: the students' main task was to collaborate in creating an extended piece of writing; the tutors' main task was to grade and give feedback on students' group work.

The research questions addressed in this paper are:

1. How effective is a wiki in supporting students who are carrying out an online group project?
2. How effective is a wiki in supporting tutors who are marking online group projects?
3. What roles do usefulness and usability play in students' and tutors' acceptance of wikis for a group project?

## Literature Review

Group work has been the focus of much research, as there are many challenges involved (Jaques & Salmon, 2007). For example, groups need to agree on who will carry out which tasks and take on which responsibilities; they also need to negotiate schedules (Kear, 2011, p. 158). A particular issue is that success for an individual can rely on the group's performance, and this may cause tensions (Davies, 2009). In a distance or online learning context, where learners are expected to work with others whom they



may never have met face-to-face, there are additional challenges (Hurst & Thomas, 2008). The communication between group members needs to be facilitated through online communication tools, synchronous (real-time) or asynchronous. In addition, the output of the group's collaboration has to be created using shared online tools.

There has been considerable research into the use of various tools for supporting students in online group work (Dron, 2007; Mason & Rennie, 2008; Olson & Olson, 2008; Wang, 2010). For supporting communication between group members, online forums are often used successfully, although these also have disadvantages (McConnell, 2006; Kear, 2011). Synchronous technologies are effective for decision-making, but require group members to be available at the same time (Finkelstein, 2006; de Freitas & Neumann, 2009). For creating a shared product, wikis and other shared websites have been investigated (West & West, 2009).

Wikis provide a workspace to generate and communicate ideas and to construct, edit, and preserve shared knowledge in a readily accessible and open environment (De Wever et al., 2011; Wheeler et al., 2008). Research on assessment of students' web 2.0 activities has revealed that wikis are commonly used tools (Gray et al., 2012) and their effectiveness as tools for online collaborative learning has been identified (Ben-Zvi, 2007; Deters et al., 2010). However, studies show that the use of a wiki does not in itself result in true collaboration (Naismith et al., 2011; Witney & Smallbone, 2011) and, in the context of wikis, a distinction needs to be made between collaborative working and co-operative working (Panitz, n.d.). Students' engagement with collaborative tasks using a wiki is dependent on a number of factors, including the availability of other online communication tools that students are more familiar with, the nature of the task, the context within which it takes place, and students' confidence in their own abilities (Benson et al., 2012; Whitney & Smallbone, 2011; Cole, 2009). Further, it has been found that there is a reluctance for students to edit each other's work (Ben-Zvi, 2007; Kear et al., 2010), which impacts on the effectiveness of a wiki for collaborative authoring. When selecting collaborative tools, we need to consider these influences.

Once tools have been identified for a particular scenario, it is of value to consider users' acceptance, or otherwise, of the new tools. A research framework that has been used for this purpose by other researchers is the technology acceptance model (TAM). This is a well-known model for understanding why people accept or resist new technologies (Davis, 1989); it has been described as "arguably, one of the most widely adopted and tested across organisational contexts, technologies, and cultures" (Teo, 2009). The original TAM identified two key factors – perceived usefulness and perceived ease of use – as primary predictors of the acceptance of a technology. Perceived usefulness is a measure of whether an individual believes that a particular technology would enhance his or her job performance. Perceived ease of use is a measure of whether an individual believes that using a particular technology would be free of effort.

The TAM has been applied to many different contexts and technologies. Of particular relevance to the research presented here are applications of the TAM to e-learning

(Roca & Gagne, 2008; Edmunds et al., 2012), weblogs (Maditinos et al., 2012) and wikis (Liu, 2010). The TAM has been revised, supplemented, and combined with other models by various authors in different contexts (Venkatesh & Davis, 2000; Brown et al., 2010; Abu-Al-Aish & Love, 2013). In particular, intrinsic motivational factors have been the focus of research which has introduced elements such as perceived enjoyment (Lee et al., 2005; Venkatesh, 2000; Davis et al., 1992) and perceived playfulness (Roca & Gagne, 2008; Moon & Kim, 2001) to the model. The recent studies by Brown et al. (2010) and Madatinos et al. (2012) are of particular relevance as they examine the acceptance of collaboration technologies, and discuss the importance of social influence in group adoption of technology.

## Context of the Research

The Open University is the largest provider of distance education in the UK, with over 250,000 students. It has a policy of open entry, enabling learners to access higher education whatever their background. Learners therefore have a wide range of prior educational and work experience, and the majority are in employment. Learners typically study part-time from their own home or workplace, over a period of nine months. Students are divided into tutor groups of around 20, with a tutor who is usually geographically local to them. The tutor provides support via group tutorials (held face-to-face or online), telephone, email, and online forums. The tutor also marks students' assignments (which are submitted electronically) and provides detailed feedback.

The initiative to use wikis began in the second level, 60-point course (equivalent to half of year 2 in an undergraduate degree) Information and Communication Technologies: people and interactions. The majority of students on this course were studying towards an undergraduate degree in Computing and IT. They were typically in the 30-49 age bracket and around three quarters were male. One of the intended learning outcomes for the course was the development of students' skills in group working via communication technologies. The course therefore included a period of study where students worked on an assessed group project. The design of the project was based on experience of group work in earlier modules (Kear, 2004). Students were assigned to project groups of up to eight members within their tutor group, with each project group given the task of producing a web resource about the concept of the cyborg. Students were provided with articles about different topics related to the cyborg concept. Each student created a web page about one of these topics, with the choice of topics discussed and allocated to individuals by the group. The group as a whole created an overview page to introduce the topics and link to the individual topic pages.

In the original project design, a set of HTML file templates was provided for each group to create their web resource, and students carried out the collaboration via an online discussion forum. The project included a peer review activity where each student submitted a draft of their web page to the forum as an attachment, and received

feedback from two other group members; the logistics of this were a group responsibility to organise. In order to allocate marks and provide feedback, the tutor monitored the forum contributions as well as reviewing the web resource produced by the group. The groups were assessed on the web resource they produced (the product) and the collaboration that took place (the process) through an examination of the final webpages and contributions in the forum. Marks were allocated on both an individual basis and a group basis. The purpose of the group marks was to encourage shared responsibility. The purpose of the individual marks was to reward students for their individual efforts.

## Use of Wikis for the Group Project

The research focused on the penultimate presentation of the course. At that time a wiki became an available tool within the Open University's new virtual learning environment (VLE). The course team decided to implement the use of a wiki for supporting the group project as a wiki seemed well-suited to the task set for students. Using a wiki in place of the HTML templates meant groups had a centralized resource to work with and it avoided the need for students to exchange updated versions of the material they produced. The wiki also provided a vehicle for the peer review activity which was an essential component of the task. In addition, the in-built history functionality of the wiki would provide an audit trail from which tutors could establish who had authored or edited the material.

Course tutors were given the option of offering wikis to their project groups; these student groups could then choose whether to use the wiki or to use the HTML templates. The wiki offered a simple discussion facility whereby participants could add comments to each other's pages, so groups could use the wiki for the peer review activity, as well as for developing their web resource. Nevertheless, a discussion forum was provided for each group, and group members could decide among themselves how to use and combine the wiki and the forum. The decision about how to use the wiki and forum were part of the challenge facing groups undertaking the group project. Deciding how to use multiple tools is an important part of any group work undertaken online.

The wikis were made available with several template pages already created. This ensured that groups using the wiki were provided with the same basic structure for creating their content as groups using the HTML templates. Unlike the HTML templates, the wiki templates included a 'Collaboration' page where students were required to document the process of their collaboration. As before, the groups were assessed both on the final product and on the collaboration that took place. Tutors marked the product by examining pages in the wiki, and marked the collaboration by looking at each individual's contributions to forum discussions (as before), together with evidence obtained from the wiki.

## Research Methods

### Student Data

Of the 33 course tutors, 12 volunteered to take part in the research, and to offer the wiki to their student groups. Permission was requested from the Open University's Student Research Project Panel, which has university-wide responsibility for reviewing and approving research involving Open University students, to gather data from these students, via an anonymous online survey. The survey, which was created using the web-based SurveyMonkey facility, was designed to gain feedback from students on their use and perceptions of the wiki for the group project. Once the group project was submitted and marked, students in the 12 volunteer tutor groups (167 students) were invited to respond to the survey.

There were 10 survey questions, as shown in Table 1. Each consisted of a closed question with four or five options. The closed questions were intended to reveal whether and how students used the wiki, how useful they found it, and how easy it was to use. In this paper we later refer to the results of the closed questions (expressed as percentages) as the quantitative data. Each question also included an open-text area, where more descriptive comments were requested. We refer to this later as the qualitative data. The open comments provided by students enabled the issues to be explored in greater depth, identifying themes related to students' choices and perceptions. This provided an opportunity to investigate the significance of perceived usefulness and perceived ease of use to students' acceptance (or otherwise) of the wiki. In a novel approach we used the primary factors identified by the TAM as a basis for coding and analysing qualitative data.

Table 1

*Survey Questions*

	Closed question	Prompt for open text area
1	Did your group use the wiki for the collaborative work in Module 3?	What were the group's reasons for using / not using the wiki in Module 3?
2	Did your group use the wiki for the collaborative work in Module 4?	What were the group's reasons for using / not using the wiki in Module 4?
3	Which of the following statements most closely matches your own experience of learning to use the wiki? [It took very little time [...]; It took a reasonable time [...]; etc.]	Please comment on your experience of learning to use the wiki:
4	Which of the following statements most closely matches your own experience of using the wiki? [The wiki was very easy to use; the wiki was fairly easy to use; etc.]	Please give your thoughts on why it was easy or difficult to use the wiki:
5	Did the wiki provide all the features you needed?	Please comment on the features provided, and any features missing from the wiki:
6	How useful did you find the wiki in supporting the group's collaborative work?	Please give your views on the value of the wiki for the group's collaborative work:
7	How did you feel about group members being able to modify each other's contributions to the wiki?	Please explain your views about group members being able to modify each other's contributions:
8	Did group members contribute equally to creating and improving material in the wiki?	Please give your comments on whether and how the work within the wiki was shared fairly:
9	How did your group use the wiki and the group forum for the collaborative work?	Please describe how your group used the wiki and/or forum:
10	How did you feel about having two communication tools available for the collaborative work?	Please give your views on the pros and cons of having both tools available:

*Note.* Modules 3 and 4 were the parts of the course where students were required to carry out collaborative work.

The prompts for the open text areas associated with Questions 1 and 2 asked students why their groups used, or did not use, the wiki. The comments received from students for these questions were coded independently by three researchers (the authors of this paper). The coding scheme, based on the factors identified by the TAM, comprised three primary elements. These were used in an initial round of coding:

- PU, for comments relating to the perceived usefulness of the wiki;
- PEOU, for comments relating to the perceived ease of use of the wiki;
- O, for other comments.

The 'Other' category included comments that did not relate to either of the previous two elements: PU or PEOU. This meant that, whilst the two categories from the TAM could be explored in detail, the investigation was not restricted to these categories, and other emerging factors could be considered. This 'Other' category, and what emerged from it, is discussed later in the paper.

Following the independent coding, the percentage match between the three coders was calculated. Then the independently assigned codes were discussed by the research team in order to arrive at a final agreed code for each comment. The percentage matches and final results are discussed in detail in the Findings section.

## Tutor Data

Feedback on the use of wikis was also sought from the tutors who took part, in order to gain their views and experiences of the wiki. Via a discussion forum, tutors were asked to comment on the following:

- whether they felt that wikis were beneficial to their students and/or to themselves as teachers;
- any problems, for students or for themselves;
- whether wikis should be combined with other tools (e.g., forums or a real-time chat tool);
- any recommendations for how wikis could best be used in the future to support group work.

All the responses posted by the tutors were copied into a word processor document for coding purposes. The coding scheme was the same as that used for coding the qualitative student data: The data were coded independently by the three researchers, and then the independently assigned codes were discussed in order to arrive at a final agreed code for each comment. However, two issues emerged early in this process which resulted in some new considerations, as discussed below.

Firstly, the tutor data was in a less structured format than the student data. This meant that the units to be coded from the tutor data were not as easily identifiable, that is, some responses comprised one or two sentences whilst others were large paragraphs which could either be treated as one or multiple units to code. The decision was made to

allow each researcher to independently code the data in its original format, with the intention to discuss the units of data at the discussion stage that followed.

Secondly, it became clear that a second dimension to the coding scheme was needed to indicate whether tutors' comments were related to the students' task (to collaboratively create a web-resource) or to their own task (to provide fair and efficient marking of the web resource and the collaboration). Therefore additional codes were used to distinguish comments that referred to the students' task (S) from those that referred to the tutors' task (T). In some cases comments applied to both (S & T).

## Findings

The main findings are summarised below. The data from students (quantitative and qualitative) are presented first, followed by the data from tutors (qualitative only).

### Findings from Students: Quantitative Data

Of the 167 students who were invited to complete the survey, 74 did so, giving a response rate of 44%. Of these 74 respondents, 62 (84%) reported that their groups used the wiki in Modules 3 and 4 (Questions 1 and 2). Because not all respondents had used the wiki, the remaining questions in the survey were answered by fewer than 74 respondents (between 61 and 69, depending on the question). In the following paragraphs, percentages are given in terms of the number of students who answered that particular survey question.

Responses to Question 3 indicated that most students found the wiki quick to learn, with 84% reporting that it took less than half an hour to learn how to use it. When responding to Question 4, 93% said that the wiki was very or fairly easy to use. However, in response to Question 5, 43% reported that there were some problems with missing or inadequate functionality. In response to Question 6, a large majority (82%) reported that they found the wiki useful for the collaborative work.

In Question 7, most students (78%) indicated they were comfortable about group members being able to edit each other's contributions in the wiki. For Question 8, most (70%) reported that group members contributed equally or fairly equally to creating and improving material in the wiki. Question 9 revealed that the most common approach was to use the wiki for contributing material and to use the forum for discussion. Responses to Question 10 showed that nearly all (97%) found it useful to have both the wiki and the forum available, but groups combined these tools in different ways (see Table 2).



Table 2

*How Groups Use the Wiki and the Forum for the Collaborative Work*

Used the wiki for most of the collaborative work.	15%
Used the forum for most of the collaborative work.	18%
Used the wiki for contributing material and the forum for discussion.	54%
Used both the wiki and forum, but not as described above.	11%
Other	2%

## Findings from Students: Qualitative Data

In the open comments boxes for Questions 1 and 2 of the survey, students elaborated on their reasons for using or not using the wiki. In total 60 comments were received on this issue. As described earlier, these comments were coded independently by three researchers, using the coding scheme PU, PEOU, and O to represent comments relating to perceived usefulness, perceived ease of use, and other issues.

The independent coding resulted in an initial 65% match between all three researchers and an 88% match between a minimum of two coders. When the codes allocated by each researcher were discussed, it was found that, where code allocations differed, this was usually due to difficulty in deciding whether a comment was related to usefulness (PU) or ease of use (PEOU). In some instances the comment related to both aspects, in which case the final agreed code was a double code (PU/PEOU). In a small number of cases, different combinations of codes (PU/O or PEOU/O) were also necessary.

A further interesting finding from the initial coding exercise was the range of comments that emerged within the 'Other' category. Upon coding the data, student comments relating to the following aspects emerged within this category:

- intrinsic motivation, comments relating to wanting a challenge or the opportunity to learn new skills;
- social influences, comments relating to peer influence within the group, tutor influence or expectations, and group decision making.

The distribution of codes across the 60 comments is summarised in Table 3. As the table shows, there was a significant number of comments in each of the main categories (PU, PEOU, and O). Comments were largely positive, and all the negative comments were related to ease of use (PEOU), sometimes in combination with other codes.

Table 3

*Coding of Comments from Students*

Code	Total number of comments	Number of positive comments	Number of negative comments
PU	17	17	0
PEOU	13	10	3
O	16	16	0
PU / PEOU	11	9	1
PU / O	1	1	0
PEOU / O	2	1	1

Students' comments on the usefulness (PU) of the wiki were mostly focused on the fact that it provided a central place for progressing the group's work. For example, one student comment was: "Good central location to collaborate on a single document."

Positive comments on ease of use (PEOU) referred to the wiki as being straightforward and intuitive to use: "Simple easy web tool, no hassle, straight forward and self explanatory."

The small number of negative comments about ease of use (PEOU) were directed at the limited editing functionalities of the wiki at that time. In particular, students wished to insert images, change or edit fonts, or copy text or tables from other word-processed documents.

As summarised earlier, comments from the third category, other (O), highlighted that students welcomed the opportunity to embrace new technology: "We used the wiki because as a group we believed we could learn new skills."

In addition, comments were received about the social influences that contributed to decisions about using the wiki: "We took the decision as a group to utilize the benefits of the wiki environment."

## Findings from Tutors

Of the 33 tutors, 21 offered the use of wikis to their student groups; this was considerably more than the 12 tutors who originally volunteered to take part in the research. As described earlier, feedback was elicited via a discussion forum. Seven of the tutors contributed to this forum and each responded to all the questions posed.

The independent coding process for the tutors' comments resulted in a very close match in terms of how the data were treated as units to be coded, with only a very few paragraphs being treated differently by the three coders. These were discussed and a unit of data agreed in each case. In total, 34 units of data, that is, separate comments, were agreed on.

The independent coding resulted in an initial 68% match between all three researchers and a 91% match between a minimum of two researchers. These figures are very similar to those for the coding of the student data.

The numbers of comments made for each code are summarised in Table 4. The same primary codes were used (PU for perceived usefulness, PEOU for perceived ease of use, O for other). However, there were no comments that needed to be coded as O (other). The table also shows the additional coding of comments from tutors according to whether the comments related to the students' (S) task (collaborating in the wiki) or the tutors' (T) task (marking the group work) or both (S & T). The table identifies whether the comments demonstrated a positive or negative perspective on that aspect.

Table 4

*Coding of Comments from Tutors*

Code	Total number of comments	Number of positive comments	Number of negative comments
PU-S	12	6	6
PEOU-S	10	5	5
PU/PEOU-S	1	0	1
PU-T	4	3	1
PU-S&T	3	2	1
PEOU-S&T	1	0	1

As Table 4 shows, tutors commented most frequently about the students' use of the wiki, rather than their own use. Generally these comments were divided equally between positive and negative perspectives.

Positive comments on usefulness for students (PU-S) suggested that the wiki had encouraged collaboration and that it enabled students to keep track of the work: "It also enable[d] everybody to see who has contributed what and when the contributions were made."

Negative comments on usefulness for students (PU-S) seemed to indicate that students were not using the wiki to its full potential: “I think that the Wiki [h]as tended to be a more 'final' document location for work discussed in the forum.”

Positive comments on ease of use for students (PEOU-S) reported that students generally found the wiki easy to use, even if they had no previous experience. One tutor said that his students, “took to it like ducks to water. It seemed natural and intuitive.”

Negative comments on ease of use for students (PEOU-S and PEOU-S&T) were all related to the limited editing functionality of the wiki.

Tutors made no direct comments on the ease of use of the wiki in relation to carrying out their own task, but they did make some comments on its usefulness for them (PU-T). These comments were mainly positive, as the tutors felt that the wiki functionality enabled them to see individual contributions: “I could see who made changes and when they were made.”

Negative comments about the usefulness of the wiki for the tutors' task (PU-T) were about the increased workload associated with marking the collaborative work. However, these comments were not considering the use of the wiki on its own – rather the use of the wiki alongside the forum: “For me, the benefit[s] (I think) are less so. Having to keep an eye on [the forum] as well as wiki involved more effort.”

## The Implementation of Wikis in the Replacement Course

The replacement course Communication and Information Technologies maintained the online group project as part of its assessment and used a similar structure, but changed the topic that students were asked to write about from 'Cyborgs' to 'Online communication and collaboration'. Students were required to write web pages on topics such as virtual worlds, Web 2.0, and social networking. In the new course all students were required to use the wiki, as it had been well received by students in the previous course.

Again, students were required to work together in small groups to produce a set of linked wiki pages, including a 'Collaboration' page documenting group decisions. To write the content for the project, groups had to create their own 'Overview' wiki page, and ensure that this linked out to the pages for individual topics, which they also had to create. The peer review element was maintained from the previous course, with each student required to provide feedback and to use the feedback they received to improve their own page. A discussion forum was available to each group for coordinating and discussing group tasks.

As described previously, this research identified concerns about tutor workload, so feedback was collected from tutors on the new course to monitor this. The course team

held three debriefing sessions for tutors via a synchronous web conferencing environment, and invited them to discuss the group project. Over the three sessions, 26 tutors attended, with a fairly equal distribution across the three sessions (9:8:9). In addition, tutors were asked to complete an end of course survey about their general experiences with the course. One of the survey questions asked them to identify assessments that were particularly slow to mark. This drew several comments regarding the group project, which revealed that assessing the collaborative process was proving to be time-consuming and difficult.

In the feedback via the debriefing sessions and survey, several tutors described the problems they were experiencing: "It was almost impossible [...] to identify contributions across several sources, wikis, forums etc. I think it was overcomplicated" (from a debriefing session) and "...collecting data on who has done what is time consuming" (from a debriefing session).

The tutors also offered suggestions which would ease their workload: "We should get the students to say what they have contributed" (from a debriefing session) and "Making it much clearer what's expected to be provided by the student, and what we're expected to find for ourselves" (from the tutor survey).

To make tutors' marking tasks easier, in subsequent presentations of the course more structure was added to the initial wiki template that students used. An overview page was created for students, and pre-defined headings were added to the 'Collaboration' page, where they were required to document aspects of the group process: 'Milestones', 'Problems', and 'Aspects that went well'.

## Discussion

The findings from this research, both quantitative and qualitative, suggested that a wiki, used together with a forum, was a valuable tool for students working on group projects to develop a shared resource. However, the wiki was found to be of less value for the tutors who were marking the group work. Using a coding approach that was based on the main factors identified by the TAM, the researchers were able to examine the qualitative data in more detail, in order to understand students' and tutors' perceptions of adopting a wiki.

In the data from students about why they used the wiki, there were many comments relating to perceived usefulness and perceived ease of use. This implies that both these factors were important in students' adoption of the wiki for their collaborative work. This finding is consistent with TAM research, which suggests that usefulness and ease of use are key factors in technology adoption (Davis, 1989; Venkatesh & Davis, 2000).

What also emerged from the student data was that factors other than usefulness and ease of use were important for students' decisions about whether to use the wiki. Some

of these factors related to the desire to develop new skills or wanting a new challenge. Others were social factors, for example peer influence within the group or tutor expectations. These findings are in line with recent research which extends the TAM to include aspects such as intrinsic motivation (Lee, Chung, & Chen, 2005; Venkatesh, 2000) and social influence (Brown et al., 2010; Madatinos et al., 2012).

Moving on to the tutors' point of view, the qualitative data from the 'early adopters' (i.e., those who volunteered to use the wiki with their student groups in the research) showed a fairly even balance between positive and negative comments. These tutors seemed to take a more critical stance on the technology than their students, and they were somewhat more critical of the wiki in relation to the students' task than their own. The coding scheme used allowed the researchers to explore the tutors' perceptions in greater detail. The tutors' comments about the students' task were relatively evenly balanced between usefulness and ease of use, while their comments on their own task were primarily about usefulness. There were no tutor comments coded as 'other', which suggests that there was no particular focus from tutors on personal motivations to use the wiki, or on social influences affecting its adoption.

Subsequently, in the implementation of wikis in the replacement course, tutors (who were all obliged to work with the wiki) were rather negative about using the wiki for their own task of marking students' collaborative work. They saw the wiki (in addition to a forum) as significantly increasing their workload because there were now two online spaces to monitor. As Trentin (2009) and De Wever et al. (2011) have pointed out, assessing group processes from the records provided by a wiki can be very time-consuming.

Using the main factors identified by the TAM to develop a coding scheme for qualitative data is a novel approach adopted in this research. It was valuable to use the primary coding dimensions of 'perceived usefulness', 'perceived ease of use' and 'other' as this revealed other influencing factors, such as enjoyment/challenge and the various social influences, that emerged from the data. As with other approaches to coding qualitative data, it was found useful to have the qualitative data structured into identifiable units (sentences or paragraphs) to enable independent coders to treat the data in a similar manner. The initial independent coding exercise, which resulted in high percentage matches, provided confidence in the coding process. The iterative process of independent coding, research team discussion, and then final code allocation was useful for prompting discussion around problematic areas.

We now return to the research questions which were addressed by this study.

1. How effective is a wiki in supporting students who are carrying out an online group project?

Both the quantitative and qualitative data from this study suggest that a wiki is effective for supporting student collaboration. Students found the wiki to be both useful and usable.

2. How effective is a wiki in supporting tutors who are marking online group projects?

The study revealed that use of a wiki, together with a forum, was perceived moderately positively by the 'early adopter' tutors, but more negatively by tutors in the large-scale implementation, who had concerns about their workload in marking the students' collaboration.

3. What roles do usefulness and usability play in students' and tutors' acceptance of wikis for a group project?

In this study, students' comments implied that usefulness and ease of use were both key aspects and that intrinsic motivation and social influence were also important factors. The tutors' comments about their own task of marking the group project implied that usefulness was the most significant factor in their acceptance of the wiki.

## Conclusion

The research reported in this paper was concerned with an online project where student groups co-produced a web resource using a wiki. The research explored the perceptions of students on using the wiki for the group project, and the reactions of tutors who were required to mark the group work. Students found the wiki useful for their collaboration, and reasonably easy to use. Tutors were less receptive to the wiki because of the additional workload it presented in assessing the collaborative process. Subsequently, in order to reduce the tutor workload, further structure was imposed on groups by defining the wiki pages to be used, and how they were to be used.

Online collaboration technologies can play a key role in supporting learning and group work, especially in distance and e-learning contexts, but users' acceptance of these technologies is influenced by several factors. As proposed by the technology acceptance model (TAM), two primary factors are perceived usefulness and perceived ease of use. This research study suggests that these two factors are key to students' decisions to adopt a wiki. The TAM has been extended in previous works to include aspects such as social influence and intrinsic motivation. Social factors, for example peer influence and tutor expectations, were also identified in the current study, as were factors related to the desire to develop new skills or take on a new challenge.

This research makes a contribution to the existing literature by considering the TAM with respect to two different user perspectives of the same technology. We investigated students' acceptance of a wiki for undertaking collaborative group work, and tutors'



acceptance of a wiki for enabling fair and efficient marking of an online group project. A key implication of this study for practitioners is that, when introducing online technologies to support collaborative activities and group projects, the perceptions and needs of both students and tutors should be carefully considered.

## Acknowledgements

We would like to thank all the students and tutors who participated in this research.

## References

- Abu-Al-Aish, A. & Love, S. (2013). Factors influencing students' acceptance of m-learning: An investigation in higher education. *International Review of Research in Open and Distance Learning*, 14(5) 82-107. Retrieved from <http://www.irrodl.org/index.php/irrodl/article/view/1631>
- Ben-Zvi, D. (2007). Using wiki to promote collaborative learning in statistics education. *Technology Innovations in Statistics Education*, 1(1) Article 4. Retrieved from <http://escholarship.org/uc/item/6jv107c7>
- Brown, S. A., Dennis, A. R., & Venkatesh, V. (2010). Predicting collaboration technology use: Integrating technology adoption and collaboration research. *Journal of Management Information Systems*, 27(2), 9-53.
- Benson, R., Brack, C., & Samarwickrema, G. (2012). Teaching with wikis: Improving staff development through action research. *Research in Learning Technology*, 20(2). Retrieved from <http://www.researchinlearningtechnology.net/index.php/rlt/article/view/16149>
- Cole, M. (2009). Using wiki technology to support student engagement: Lessons from the trenches. *Computers & Education*, 52(1), 141-146.
- Davies, W. M. (2009). Groupwork as a form of assessment: Common problems and recommended solutions. *Higher Education*, 58, 563-584.
- Davis, F. D. (1989). Perceived usefulness, perceived ease of use, and user acceptance of information technology. *MIS Quarterly*, 13, 319-339.
- Davis, F. D., Bagozzi, R. P., & Warshaw, P. R. (1992). Extrinsic and intrinsic motivation to use computers in the workplace. *Journal of Applied Social Psychology*, 22, 1111-1132.
- Deters, F., Cuthrell, K., & Stapleton, J. (2010). Why wikis? Student perceptions of using wikis in online coursework. *MERLOT Journal of Online Learning and Teaching*, 6(1), 122-133.
- De Wever, B., Van Keer, H., Schellens, T., & Valcke, M. (2011). Assessing collaboration in a wiki: The reliability of university students' peer assessment. *Internet and Higher Education*, 14(4), 201-206.
- Dron, J. (2007). *Control and constraint in e-learning: Choosing when to choose*. London and Hershey, PA: Idea Group Publishing.

- Edmunds, R., Thorpe, M., & Conole, G. (2012). Student attitudes towards and use of ICT in course study, work and social activity: A technology acceptance model approach. *British Journal of Educational Technology*, 43(1), 71–84.
- Finkelstein, J. (2006). *Learning in real time*. San Francisco: Jossey Bass.
- de Freitas, S., & Neumann, T. (2009). Pedagogic strategies supporting the use of synchronous audio conferencing: A review of the literature. *British Journal of Educational Technology*, 40(6), 980-998.
- Gray, K., Waycott, J., Clerehan, R., Hamilton, M., Richardson, J., Sheard, J., & Thompson, C. (2012). 'Worth it? Findings from a study of how academics assess students' Web 2.0 activities'. *Research in Learning Technology*, 20(1). Retrieved from <http://www.researchinlearningtechnology.net/index.php/rlt/article/view/16153>
- Hurst, D., & Thomas, J. (2008). Developing team skills and accomplishing team projects online. In T. Anderson (Ed.), *The theory and practice of online learning* (2<sup>nd</sup> ed., pp. 441-472). Athabasca, Canada: AU Press.
- Jaques, D., & Salmon, G. (2007). *Learning in groups: A handbook for face-to-face and online environments*. Abingdon: Routledge.
- Kear, K. (2004). Peer learning using asynchronous discussion systems in distance education. *Open Learning*, 19(2), 151-164.
- Kear, K., Woodthorpe, J., Robertson, S., & Hutchison, M. (2010). From forums to wikis: Perspectives on tools for collaboration'. *The Internet and Higher Education*, 13(4), 218-225.
- Kear, K. (2011). *Online and social networking communities: A best practice guide for educators*. New York: Routledge.
- Liu, X. (2010). Empirical testing of a theoretical extension of the technology acceptance model: An exploratory study of educational wikis. *Communication Education*, 59(1), 52-69.
- Lee, M. K. O., Cheung, C. M. K., & Chen, Z. (2005). Acceptance of internet based learning medium: the role of extrinsic and intrinsic motivation. *Information & Management*, 42(8), 1095–1104.
- Maditinos, D. I., Therious, G. N., & Keisidou E. (2012). Exploring the factors associated with weblog usage acceptance: Evidence from Cyprus. *International Journal of Web Based Communities*, 8(2), 196-212.

- Mason, R., & Rennie, F. (2008). *E-learning and social networking handbook: Resources for higher education*. New York: Routledge.
- McConnell, D. (2006). *E-learning groups and communities*. Maidenhead: Open University Press.
- Moon, J., & Kim Y. (2001) Extending the TAM for a world-wide-web context. *Information & Management*, 38, 217-230.
- Naismith, L., Lee, B.H. & Pilkington, R.M. (2011) Collaborative learning with a wiki: Differences in perceived usefulness in two contexts of use. *Journal of Computer Assisted Learning*, 27, 228-242.
- Olson, G. M., & Olson, J. S. (2008). 'Groupware and computer-supported cooperative work'. In A. Sears & J.A. Jacko (Eds.), *The human computer interaction handbook: Fundamentals, evolving technologies and emerging applications* (2<sup>nd</sup> ed., pp. 545-558). New York: Lawrence Erlbaum Associates.
- Panitz, T. (n.d.). Collaborative versus cooperative learning: A comparison of the two concepts which will help us understand the underlying nature of interactive learning. Retrieved from [http://pirun.ku.ac.th/~btun/pdf/coop\\_collab.pdf](http://pirun.ku.ac.th/~btun/pdf/coop_collab.pdf).
- Roca, J. C., & Gagne, N. (2008). Understanding e-learning continuance intention in the workplace: A self-determination theory perspective. *Computers in Human Behaviour*, 24(4), 1585–1604.
- Teo, T. (2009). Is there an attitude problem? Reconsidering the role of attitude in the TAM. *British Journal of Educational Technology*, 40(6), 1139 –1141.
- Trentin, G. (2009). Using a wiki to evaluate individual contribution to a collaborative learning project. *Journal of Computer Assisted Learning*, 25, 43-55.
- Wang, Q. (2010). Using online shared workspaces to support group collaborative learning. *Computers & Education*, 55, 1270–1276.
- West, J. A., & West, M. L. (2009). *Using wikis for online collaboration: The power of the read-write web*. San Francisco: Jossey-Bass.
- Wheeler, S., Yeomans, P., & Wheeler, D. (2008). The good, the bad and the wiki: Evaluating student-generated content for collaborative learning. *British Journal of Educational Technology*, 39, 987-995.
- Witney, D., & Smallbone, T. (2011). Wiki work: Can using wikis enhance student collaboration for group assignment tasks?. *Innovations in Education and Teaching International*, 48(1), 101-110.

Venkatesh, V. (2000). Determinants of perceived ease of use: Integrating control, intrinsic motivation, and emotion into the technology acceptance model. *Information Systems Research, 11*, 342-365.

Venkatesh, V., & Davis, F. D. (2000). A theoretical extension of the technology acceptance model: Four longitudinal field studies. *Management Science, 46*(2), 186–204.

Athabasca University 



## Considering High School Students' Experience in Asynchronous and Synchronous Distance Learning Environments: QoE Prediction Model



Toni Malinovski, Marina Vasileva, Tatjana Vasileva-Stojanovska, and Vladimir Trajkovik  
Macedonia, the former Yugoslav Republic of

### Abstract

Early identification of relevant factors that influence students' experiences is vitally important to the educational process since they play an important role in learning outcomes. The purpose of this study is to determine underlying constructs that predict high school students' subjective experience and quality expectations during asynchronous and synchronous distance education activities, in a form of *quality of experience* (QoE). One hundred and fifty-eight students from different high schools participated in several asynchronous and synchronous learning sessions and provided relevant feedback with comparable opinions regarding different conditions. Structural equation modeling was used as an analytical procedure during data analysis which led to a QoE prediction model that identified relevant factors influencing students' subjective QoE. The results demonstrated no significant difference related to students' behavior and expectations during both distance education methods. Additionally, this study revealed that students' QoE in any situation was mainly determined by motivational factors (intrinsic and extrinsic) and moderately influenced by ease of use during synchronous or quality of content during asynchronous activities. We also found moderate support between technical performance and students' QoE in both learning environments. However, opposed to existing technology acceptance models that stress the importance of attitude towards use, high school students' attitude failed to predict their QoE.

**Keywords:** Quality of experience; distance learning; high school students; structural equation modeling; survey

Distance education has emerged as a response to a general need for access to learning where face-to-face education is not possible (Beldarrain, 2006). The incredible growth of internet and widespread use of computers in the last decade have opened tremendous possibilities for distance learning. Different distance education programs were incorporated in traditional schools or provided a flexible way of learning in today's virtual schools (K–12 level) and virtual universities that deliver full curriculum online (Barbour, 2011; Hew & Cheung, 2010; Stricker, Weibel, & Wissmath, 2011). Distance education possibilities in high schools or virtual schools do not differ from the ones available to other state and private educational institutions. Regardless of the pedagogical approach or the technological tools, they can be roughly categorized as asynchronous and synchronous delivery methods (Bernard et al., 2009; Murphy, Rodríguez-Manzanares, & Barbour, 2011; Oztok et al., 2013; Somenarain, Akkaraju, & Gharbaran, 2010). Asynchronous distance learning solutions support relations between students and the teacher, separated by time and distance. The teacher-student interaction is facilitated through streaming media, emails, discussion boards, social media, and so on, and can reach a high phase of critical thinking since the students have more time to reflect, interact with the content, and process the information (Hrastinski, 2008; Robert & Dennis, 2005). Synchronous distance learning solutions provide real time teacher-student interaction while closely resembling a face-to-face educational environment. The synchronous communication is performed online via video/audio conferencing, instant messaging, real-time collaboration applications, and so on, while live interaction with the teacher and immediate feedback support the traditional pedagogies and different innovative methods for effective teaching and learning (Gillies, 2008; Lawson et al., 2010).

Evolving high schools that try to incorporate distance learning activities can use asynchronous, synchronous, or a combination of both learning solutions in a blended environment where students learn part of the content online. In like manner, Powell and Patrick's (2006) snapshot of the current state of K-12 e-learning in the world provided a survey's results which indicate that virtual schools are already active in many countries while using asynchronous and synchronous delivery models. Different studies have tried to compare asynchronous and synchronous delivery methods in terms of educational possibilities, learning efficiency, student retention, and teachers' approach (Hrastinski, 2008; Murphy, Rodríguez-Manzanares, & Barbour, 2011; Somenarain, Akkaraju, & Gharbaran, 2010), while others have evaluated both learning solutions against face-to-face education (Beldarrain, 2006; Bernard et al., 2004; Jaques & Salmon, 2012). On the other hand, while consumer-centricity has become a growing trend in different areas that utilize technological solutions, research studies that follow a student-centered approach in the distance education area are still scarce, especially involving high school students. Still, the ones that are available have demonstrated that student-centered environments in distance education that focus on the students' experience can be linked to increased learning achievements (Chang & Smith, 2008; Donavant, 2009; Eom, Wen, & Ashill, 2006).



This study aims to identify relevant factors that influence high school students' subjective experience and quality expectations during distance education activities, in a form of *quality of experience* (QoE). Even though high and virtual schools can have adult students attending courses, we focused on students within a typical high school age span as a selected target group and investigated their subjective expectations while using distance learning systems. Thus we developed a QoE prediction model, which can adequately forecast high school students' experience as a step towards increased learning outcomes. Having in mind the different nature of available distance education methods, we compared the proposed model between classes that incorporate asynchronous and synchronous activities, with results that provide guidelines for future educational development.

## Literature Review

Even though literature on distance education has boomed over the last decade with a large proportion of comparisons between distance and face-to-face education (Beldarrain, 2006; Bernard et al., 2004; Cavanaugh et al., 2004; Giancola, Grawitch, & Borchert, 2009; Jaques & Salmon, 2012), only a limited number of studies have compared different distance education methods and solutions, especially from students' point of view. Johnson's (2008) comparison study focused only on text-based discussions while concluding that both asynchronous and synchronous forms of online discussion contribute to students' cognitive and affective outcomes. Hrastinski (2008) discovered that asynchronous communication increases a person's ability to process information, while students participating in synchronous communication felt more psychologically aroused and motivated. Somenarain, Akkaraju, and Gharbaran (2010) found no significant difference in student satisfaction while participating in asynchronous and synchronous learning environments. Although some of the mentioned studies attempted to transfer the focus to the e-learner while comparing different conditions, there is an important gap for empirical research that evaluates students' perceptions in distance learning environments, especially relying on validated instruments.

Furthermore, there is a lack of information on the nature of high school students and evidence for the necessity to separate them from the rest of the distance learning population. The present generation involved in K–12 environments has been fitted into the stereotype of “digital native”, since they are growing up with emerging new communication technologies (Koutropoulos, 2011; Li & Ranieri, 2010; Oblinger, 2005; Prensky, 2001). Recent studies suggest that we need to move beyond this concept based purely on generational differences, showing that breadth of use, experience, self-efficacy, and education are also important (Helsper & Eynon, 2010; Steinweg, Williams, & Stapleton, 2010). Therefore, if we approach high school students as the same as any distance education practitioner and evaluate multiple variables that influence students'

behavior and expectations we can provide results that explain their nature and subjective experience.

Since student's perceptions and experience are out of mind opinions, it is difficult to measure, quantify, and even predict QoE outcomes. Different studies have proposed approaches based on QoE concepts that focus on quality perceived by the end-user from different systems, while exploring its relationship with technical parameters like quality of video/audio (Khan, Sun, & Ifeachor, 2012; Knoche & Sasse, 2008), networking performance (Zapater & Bressan, 2007), system parameters, and so on. Laghari and Connelly (2012) approached QoE as an assessment of the human experience when interacting with technology and business entities in a particular context, while presenting a high-level model in a communication ecosystem. Gong et al. (2009) defined a QoE model consisting of five factors, availability, usability, integrality, retainability and instantaneousness, while mainly focusing on the relationship between the technical and QoE parameters. Malinovski, Lazarova, and Trajkovik (2012) focused on the social aspect during usage of online learning portals and proposed a model where simplicity and adaptability of the system predict students' experience. In like manner, there have been additional attempts to provide a QoE model and substantial analysis (Janowski & Papir, 2009; Kilkki, 2008), but still lots of inconsistencies remain during identification of relevant influencing factors.

Having in mind that research studies which demonstrate relevant students' QoE models in distance learning environments are almost nonexistent, we have to consider valid technological acceptance models and sound theories in the distance education area to conduct significant QoE research. The technology acceptance model (TAM) addressed user acceptance of informational systems, while specifying the casual relationship between perceived usefulness, ease of use, attitude, and actual usage behavior (Davis, Bagozzi, & Warshaw, 1989; Lee, Cheung, & Chen, 2005; Liu et al., 2010). Sahin and Shelley (2008) based their research on TAM during selection and measurement of variables, while proposing a model which suggested that students' computer knowledge, perceived usefulness, and flexibility of distance education should be considered as predictors of students' satisfaction in online learning environments.

On the other hand, the motivational theories have recognized motivation as an important factor for academic success, while different analyses showed a division between extrinsic (external) and intrinsic (self-determined) motivators (Lee, Cheung, & Chen, 2005; Ryan & Deci, 2000). Intrinsically motivated students are more persistent and more likely to achieve set goals since they are engaging in learning for the inherent satisfaction of acquiring knowledge (Hardre & Reeve, 2003; Murphy & Rodríguez-Manzanares, 2009). Even though generally intrinsic motivation is more effective and lasting than extrinsic motivation (Gagné & Medsker, 1996), the external motivating factors (e.g., higher grades, social influence, etc.) are important drivers capable of evoking specific behavior in distance education environments (Ryan & Deci, 2000),

especially since high school students may have less intrinsic motivation (Smith, Clark, & Blomeyer, 2005).

In this study we adopted the importance of students' motivation in distance learning environments and combined it with certain variables from TAM (ease of use and attitude) since the adoption of new technology is also determined by extrinsic and intrinsic motivators (Davis, Bagozzi, & Warshaw, 1992; Lee, Cheung, & Chen, 2005). Furthermore, we go beyond mere technology acceptance while trying to determine factors that can influence a higher level of positive high-school students' QoE in distance education settings. We used some of the variables from existing studies to define constructs that can forecast students' QoE while further comparing outcomes during online asynchronous and synchronous learning conditions.

## Methodology

### Participants and Design

This study aimed to identify factors that influence high school students' QoE from distance education environments which involve asynchronous and synchronous activities. Therefore in our research activities, we included 158 students from five high schools in Macedonia, two in the capital city and three in other towns. Among the participants, 55.7% ( $n = 88$ ) were male and 44.3% ( $n = 70$ ) were female, 15-16 years old, while 57.6% of them used computers everyday at home for school activities, 27.8% used computers two-three times a week, 5.1% once a week, and 9.5% did not use computers at home. Students without computers at home were asked to perform the necessary activities using school equipment at their own pace, so they could successfully participate in the research. During the 2012-2013 school year we introduced distance education methods on three different subjects (math, science and art), in two learning sessions with similar topics per subject, while using different distance learning activities. Hence the participants attended a total of six learning sessions (asynchronous and synchronous in three subjects) and were able to provide relevant feedback with comparable opinions regarding different conditions. The student sample and the design provided a representative group which participated in various classes and thus diminished students' preference towards specific subjects.

The teachers provided streaming videos and notes for each lecture on the schools' learning portals during the asynchronous activities and discussed the materials with students over email and the portals' forum. Therefore students were able to use the online curricular materials on their own time for a few days and collaborate with their classmates under guidance of the teachers. The synchronous activities were conducted in class with videoconferencing sessions between two high schools in different cities.

Each videoconferencing site had a teacher/student camera, proper sound systems, and two displays for both parties during the two-way video communication. The first part of the lecture was presented by the teacher in one site, was concluded by the teacher in the other site, and was followed by interactive discussion among participants. Students' feedback information was collected through surveys after each learning session, which included questions regarding students' opinions to the interest of this study, that were further used as research variables. Links to surveys during asynchronous activities were provided on the schools' learning portals for easy access, while during videoconferencing-based sessions the surveys were performed online at the end of each class.

## Measures

Since multi-item measures are more adequate than single-item when measuring complex constructs (Nunnally & Bernstein, 1994), such as students' perceived QoE and influencing factors, we defined a large set of observed variables while forming five complex unobserved variables, referred to as latent constructs. Details of the instruments are described below, with the necessary difference for different learning conditions.

### **Technical performance.**

In line with existing studies that provided relations between quality perceived by end-users from different systems and delivered technical performance (Khan, Sun, & Ifeakor, 2012; Zapater & Bressan, 2007), we evaluated a technical performance variable (TECH) during asynchronous/synchronous learning sessions. The surveys contained a section regarding students' perception of the technical conditions: students' perceived quality of the video (T1) and audio (T2) signals; beliefs regarding adequate audio/video synchronization (T3); and proper functioning of equipment during videoconferencing sessions and streaming media delivery for the asynchronous activities (T4).

### **Easy usage and content.**

Technology acceptance models have stressed the importance of usability with different technological solutions, since the "easy to use" approach does influence end-users' experience. Therefore we formed an easy usage variable (EASY) during videoconferencing sessions constructed from four observed items in our questionnaires: the level of appropriate teacher-student live interaction (E1); students' perceived easiness in following the lessons (E2); the degree to which students were able to easily understand the content (E3); and ease of use of the videoconferencing equipment (E4).

In the course of our research activities, we found that the content delivered through streaming videos and lecture notes played a more important role than ease of usage of the schools' portals during asynchronous learning. This notion is consistent with Lee, Cheung, and Chen's (2005) findings suggesting that perceived ease of use is no longer a

crucial factor when students use internet-based learning portals. Therefore we made a slight distinction and used content instead of easy usage as a research variable (CONT) for these activities. We have constructed CONT from the following observed variables: quality of instructions within the recorded materials and lecture notes (C1); students' opinion of the content modules and online discussions in regards to subjects' topic (C2); and students' beliefs regarding appropriateness of content to their high-school level (C3).

### **Attitude.**

The attitude of high school students towards distance education novelties in the learning environment is important since TAM and similar technology acceptance models have linked attitude and intention to use (Davis, Bagozzi, & Warshaw, 1989; Lee, Cheung, & Chen, 2005). Therefore we researched attitude as a variable (ATT) in asynchronous and synchronous learning conditions, constructed from level of acceptance of the following: new teaching approach (A1); students' beliefs regarding collaboration and intuitive atmosphere (A2); and students' attitude towards novelties in teaching practice in general (A3).

### **Motivation.**

The importance of students' motivation in distance education has been widely recognized (Ryan & Deci, 2000) and strongly linked with students' learning achievements (Tüzün et al., 2009). Xie, Debacker, and Ferguson's (2006) findings demonstrated that perceived interest (intrinsic motivator) and value as extrinsic motivation positively correlated with online students' course attitude and engagement, while Chen and Jang (2010) provided a research model with evidence for the mediating effect of need satisfaction between contextual support, motivation, and self-determination. Thus, we evaluated high-school students' motivation (MOTIV) through a section in the questionnaires that focused on the following: motivation for the challenge and new teaching approach (M1) and interest to use distance education activities for other subjects on their own initiative (M2) as intrinsic motivators; students' beliefs to enhance grades through distance learning activities (M3) and students obligation to use/reuse streaming video or recorded videoconferencing sessions after class for learning (M4) as extrinsic motivators.

### **Quality of experience.**

Since QoE is out of the mind opinion and can relate to fun activities during learning, students' satisfaction (Sahin & Shelley, 2008), perceived effectiveness, and so on, we formulated high school students' experience as an unobserved variable (QoE) from asynchronous and synchronous distance education environments, measured by the following: students' perceived experience for natural feeling and increased efficiency (Q1); beliefs for increased possibilities and productivity (Q2); the degree to which students think this type of learning is interesting and enjoyable (Q3); and overall students' satisfaction from the new learning environments (Q4).

## Data Analysis

Students' feedback information was gathered through a questionnaire after each learning session that covered all measures of the five latent constructs, phrased on a five-point Likert scale (where 1 = *strongly disagree* and 5 = *strongly agree*). Internal consistency of the surveyed items for each construct was assessed through Cronbach's alpha test (Cronbach, 1951) as evidence that the research items measure the underlying construct. In addition, we tested the adopted constructs for necessary validity that demonstrates the degree to which they represent the theoretical concepts (Colliver, Conlee, & Verhulst, 2012).

Structural equation modeling (SEM) was used as a two-step analytical procedure: first to test and estimate complex relationships between observed (measured) variables and referred unobserved (latent) constructs through a development of a measurement model; and then to evaluate relationships between the latent constructs with a structural model (Bollen, 1998; Byrne, 2001), especially their influence on the QoE variable. SEM surpasses multiple regression, discriminant analysis, or principle components analysis (Chin, 1998) and is particularly useful in social/behavior research where many variables (e.g., attitude, motivation, and experience) are not directly observable, while taking into account the measurement errors. The statistical analyses in this study were conducted using Statistical Package for Social Sciences (SPSS) and Analysis of Moment Structures (AMOS) software. We evaluated a structural model to estimate relationships and predict high school students' QoE during asynchronous and synchronous distance education activities, while comparing results between the different learning conditions.

## Results

Following the proposed methodology, we collected students' feedback information on all research variables through questionnaires and received 470 students' responses from the asynchronous learning activities and 473 responses from classes organized with videoconferencing sessions between two different high schools, representing a response rate above 99% in both situations. The students participated in all learning sessions, so they were able to compare and express their subjective experience on each teaching approach while practising three different subjects.

## Descriptive Statistics

Since proper univariate statistical analysis is important to screen the nature of gathered data, we examined the measures for mean score and standard deviation of the observed variables within asynchronous and synchronous environments, before submitting the research dataset for factor analyses. We also evaluated internal consistency and

reliability of each construct through Cronbach's alpha test in both learning conditions with results analytically presented in Table 1.

Table 1

*Descriptive Statistics for the Observed Variables and Reliability of Constructs*

Latent construct	Observed variable	(A) Learning (n = 470)		(S) Learning (n = 473)	
		Mean	S. D.	Mean	S. D.
TECH (A) $\alpha = 0.901$ (S) $\alpha = 0.943$	T1	4.54	0.752	4.15	1.121
	T2	4.44	0.888	3.97	1.175
	T3	4.51	0.777	4.04	1.145
	T4	4.60	0.720	4.16	1.129
EASY (S) $\alpha = 0.896$	E1	-	-	4.51	0.890
	E2	-	-	4.67	0.901
	E3	-	-	4.59	0.850
	E4	-	-	4.50	0.972
CONT (A) $\alpha = 0.893$	C1	4.70	0.725	-	-
	C2	4.67	0.715	-	-
	C3	4.68	0.738	-	-
ATT (A) $\alpha = 0.835$ (S) $\alpha = 0.876$	A1	4.68	0.697	4.67	0.855
	A2	4.61	0.700	4.53	0.878
	A3	4.63	0.683	4.67	0.800
MOTIV (A) $\alpha = 0.888$ (S) $\alpha = 0.913$	M1	4.69	0.740	4.67	0.891
	M2	4.66	0.756	4.59	0.915
	M3	4.56	0.859	4.55	0.940
	M4	4.64	0.765	4.60	0.958
QoE (A) $\alpha = 0.904$ (S) $\alpha = 0.928$	Q1	4.73	0.672	4.63	0.851
	Q2	4.60	0.829	4.55	0.877
	Q3	4.70	0.718	4.63	0.881
	Q4	4.67	0.743	4.65	0.869

*Note.* S.D. = standard deviation,  $\alpha$  = Cronbach's alpha during asynchronous (A) and synchronous (S) learning activities

We noticed that students' responses in the questionnaires covered all possible grades from 1 (*strongly disagree*) to 5 (*strongly agree*) on different variables, but as shown in Table 1, the descriptive results demonstrated satisfactory standard deviation in both learning conditions, indicating that students' responses were constructive in nature. From the initial results we can conclude that the level of students' QoE was slightly higher during asynchronous learning, the technical setup was graded lower during videoconferencing sessions, while the rest of the variables show similar behavior. Still deeper analysis requires factor correlation between each construct and observed variables, as well as presentation of the relationships between constructs by regression or path coefficients. Since as a rule of thumb, Cronbach's alpha values higher than 0.70



represent good internal consistency (Nunnally & Bernstein, 1994), the results show that the proposed constructs have strong correlations between items and can be used for model development, especially since high values do not mean that the scale is unidimensional.

## Measurement Model

According to Kline (2005) SEM is a large sample technique and complicated path models need at least a sample size of 200 observations. We obtained more than 400 responses from the high school students during both learning conditions and therefore were able to model causal relations between the construct variables, especially influence of multiple variables on students' QoE. But first we explored adequacy of the observed variables as indicators for the latent constructs (referred to as factor loadings) through evaluation of a measurement model in both environments. The collected data set from the students' responses was examined within the measurement model, having in mind that standardized factor loadings estimates should be 0.5 or higher, and ideally 0.7 or higher (Nunnally & Bernstein, 1994). In addition, the measurement model was tested for convergent validity through two additional measures: average variance extracted (AVE) and construct reliability (CR) for each construct, derived from provided factor loadings with results demonstrated in Table 2.



Table 2

*Results from the Measurement Model during Asynchronous (A) and Synchronous (S) Learning Activities*

Latent construct	Variable	(A) Factor loadings	(S) Factor loadings
TECH (A) CR = 0.887, AVE = 0.702 (S) CR = 0.956, AVE = 0.808	T1	0.829	0.874
	T2	0.837	0.913
	T3	0.867	0.925
	T4	0.817	0.883
EASY (S) CR = 0.874, AVE = 0.686	E1	-	0.779
	E2	-	0.866
	E3	-	0.878
	E4	-	0.785
CONT (A) CR = 0.915, AVE = 0.739	C1	0.825	-
	C2	0.899	-
	C3	0.853	-
ATT (A) CR = 0.825, AVE = 0.635 (S) CR = 0.892, AVE = 0.707	A1	0.736	0.857
	A2	0.896	0.817
	A3	0.748	0.848
MOTIV (A) CR = 0.860, AVE = 0.670 (S) CR = 0.907, AVE = 0.727	M1	0.810	0.888
	M2	0.843	0.852
	M3	0.801	0.814
	M4	0.820	0.855
QoE (A) CR = 0.895, AVE = 0.711 (S) CR = 0.930, AVE = 0.762	Q1	0.799	0.883
	Q2	0.827	0.844
	Q3	0.861	0.876
	Q4	0.884	0.887

As seen in Table 2, the observed variables regress highly on respective constructs with factor loadings above 0.7, as evidence that the research items provide adequate measurement of each underlying construct. On the other hand, a good rule of thumb is that  $AVE \geq 0.5$  indicates adequate convergent validity and CR should be at least 0.7 for the factor loadings on each construct, even though values between 0.6 and 0.7 may be acceptable. Thus, CR and AVE values were above the desired thresholds and therefore supported the validity of measures in both learning conditions.

Still, when we further analyzed the results, we noticed that T4 in the asynchronous, A2 in the synchronous model, and their error measurements have high value for modification indices with some of the other factors (Hair et al., 1998). High values for modification indices may guide minor modifications in the model in order to improve the fit and estimate the most likely relationships between variables. Therefore we explored the option to remove these variables and improve goodness-of-fit statistics through a structural model refinement process, especially since these modifications are theoretically acceptable.

## Structural Model

We analyzed complex relationships between the latent constructs and their behavior while influencing high school students' QoE in the researched environments through development of a structural model for both learning conditions. Since SEM does not have a single statistical test that can determine whether the specified model fits the research data, we subjected the model to various tests with the sole purpose of validating the model and arriving at the best-fit model. We evaluated the initial model and an alternative (revised) model which excluded T4/A2 for the asynchronous/synchronous environments (Table 3), while comparing the following fit indices against acceptance levels, as suggested by previous research: relative chi-square (Wheaton et al., 1977); goodness of fit index (Joreskog & Sorbom, 1984); comparative fit index (Kline, 2005); normed fit index (Bentler & Bonett, 1980); and root mean square error of approximation (MacCallum, Browne, & Sugawara, 1996).

Table 3

*Model Fit Indicators of the Initial and Revised Models during Asynchronous (A) and Synchronous (S) Learning Activities*

Indicator	Suggested guidelines	(A) Learning initial model	Revised model	(S) Learning initial model	Revised model
Chi-square (CMIN)	-	522.445	419.644	578.979	474.948
Degrees of freedom (df)	-	126	110	143	126
Relative chi-square (CMIN/df)	< 5	4.146	3.815	4.049	3.769
Goodness of fit index (GFI)	≥ 0.9	0.890	0.905	0.884	0.901
Comparative fit index (CFI)	≥ 0.9	0.939	0.949	0.951	0.958
Normed fit index (NFI)	≥ 0.9	0.922	0.932	0.936	0.944
Root mean square error of approximation (RMSEA)	< 0.08	0.082	0.077	0.080	0.077

The fit statistics reported that the revised model was improved through the refinement process in both environments and therefore we selected the revised model as final among the two alternatives. Furthermore, these modifications do not significantly change the the constructs' nature, since streaming media delivery during asynchronous activities (T4) within standard schools' portals and beliefs regarding intuitive atmosphere (A2) during videoconferencing can be neglected and derived from the remaining measurements.

Thus we obtained the final structural model that adequately explains and has the ability to predict high school students' QoE in an asynchronous distance education environment (Figure 1).

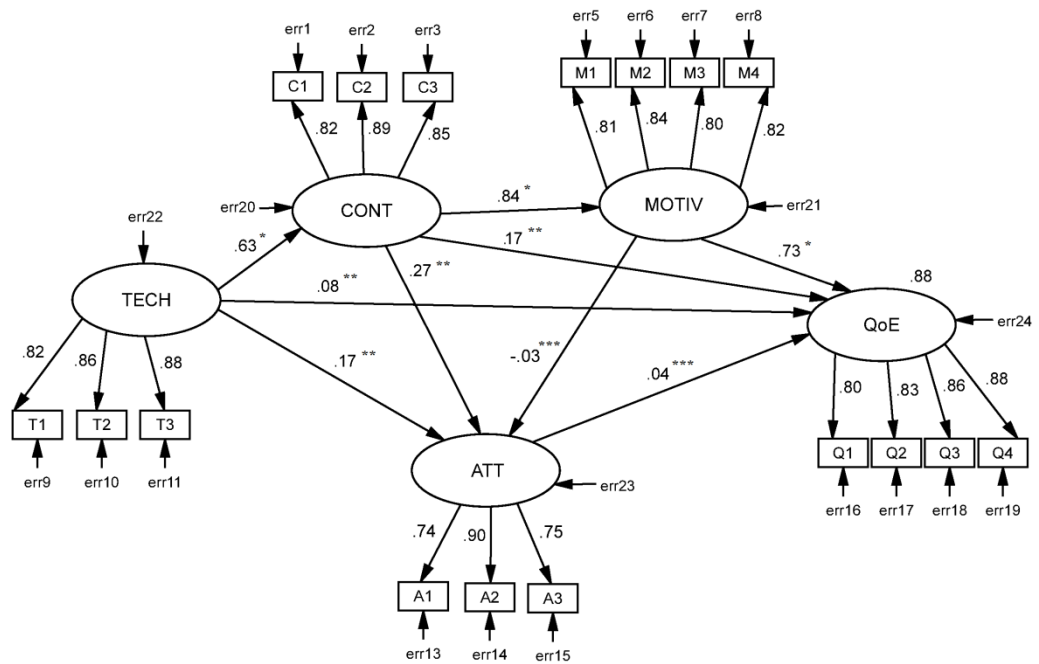

Figure 1. High school students' QoE prediction model in an asynchronous learning environment (\* $p < 0.001$ , \*\* $p < 0.05$ , \*\*\* $p > 0.05$ , two-tailed).

The presented model shows the relationships (paths) between latent constructs, while formulating one exogenous and four endogenous variables. The TECH (exogenous) variable is influenced by factors outside of the model that come from the technical setup, networking and system performance, while the endogenous variables are explained by other constructs via structural model relationships. These relationships are formulated generally and might be fitted for distance education students of varying ages, but the actual results demonstrate beliefs of high school students while participating in asynchronous learning activities. As shown here, the QoE construct (high school students' perceived QoE) is significantly determined by MOTIV ( $\beta = 0.73$ ,  $p < 0.001$ ), CONT ( $\beta = 0.17$ ,  $p < 0.05$ ), and TECH ( $\beta = 0.08$ ,  $p < 0.05$ ), while accounting for  $R^2$  of 0.88 in the QoE construct. During asynchronous e-learning students' activities depend on their own will to study and use the materials, so it seems logical that students' motivation significantly influenced their perceived QoE. Additionally, the content and the technical behavior also contributed to students' QoE, while students' attitude towards the new teaching approach did not correlate with their overall experience (ATT/QoE reported path with  $p > 0.05$ ). The path coefficients, illustrating correlation between the other constructs, show significant influence between CONT/MOTIV ( $\beta = 0.84$ ,  $p < 0.001$ ) and TECH/CONT ( $\beta = 0.63$ ,  $p < 0.001$ ), and positive effect between CONT/ATT ( $\beta = 0.27$ ,  $p < 0.05$ ) and TECH/ATT ( $\beta = 0.17$ ,  $p < 0.05$ ). Therefore the content delivered through the streaming videos and lecture notes strongly influenced students' motivation and also correlated with their attitude. The

results demonstrate that students' perceptions of the technical performance were important and were correlated with the perceived notion of content and their attitude towards the new learning environment. Consequently, we did not find direct significant statistical effect between students' motivation and their attitude, since MOTIV/ATT reported path with  $p > 0.05$ .

Following our research methodology we constructed a similar structural model and examined model fit during synchronous activities, as shown in Figure 2.

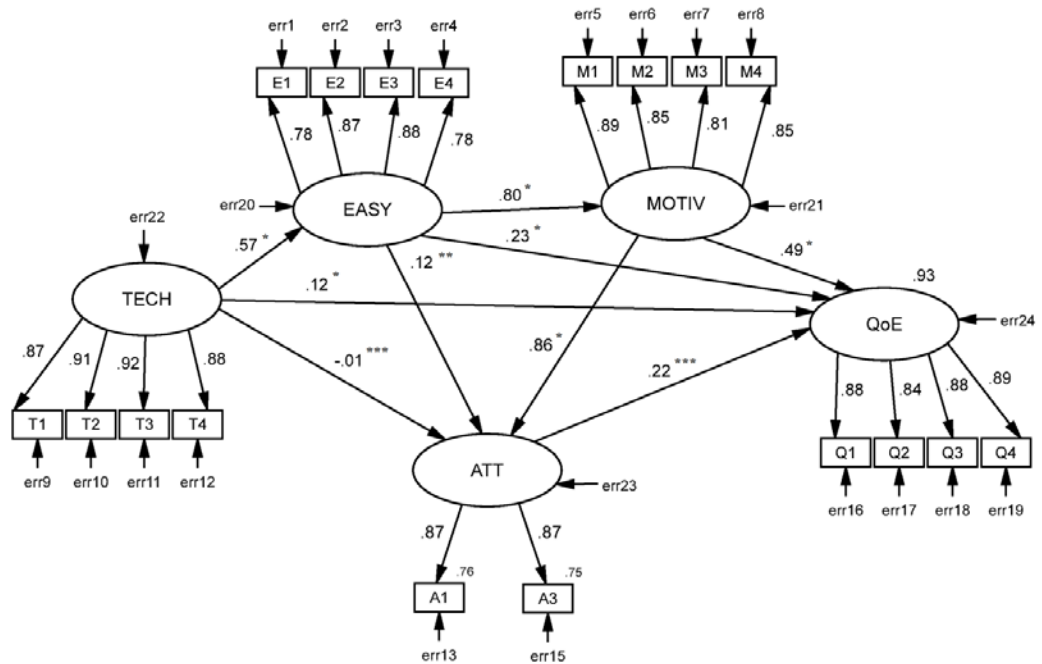

Figure 2. Structural model for QoE prediction in a synchronous learning environment (\* $p < 0.001$ , \*\* $p < 0.05$ , \*\*\* $p > 0.05$ , two-tailed).

The results from the structural model during synchronous learning activities show similar behavior to the asynchronous model, with overall model variance effect size of  $R^2 = 0.93$  for the QoE construct. In like manner high school students' QoE was significantly determined by MOTIV ( $\beta = 0.49$ ,  $p < 0.001$ ), EASY ( $\beta = 0.23$ ,  $p < 0.05$ ), and TECH ( $\beta = 0.12$ ,  $p < 0.001$ ), which is similar to the asynchronous settings, with the predetermined distinction for EASY and CONT. We found additional patterns, where ease of usage during videoconferencing sessions significantly influenced students' motivation (EASY/MOTIV reported  $\beta = 0.80$ ,  $p < 0.001$ ) and had moderate effect on attitude towards the new environment (EASY/ATT reported  $\beta = 0.12$ ,  $p < 0.05$ ). Additionally, the motivating factors had significant impact on students' attitude (MOTIV/ATT reported  $\beta = 0.86$ ,  $p < 0.001$ ), while the technical setup influenced students' beliefs for ease of usage (TECH/EASY reported  $\beta = 0.57$ ,  $p < 0.001$ ).

However, we found that technical performance did not influence high school students' attitude towards synchronous learning methods, since the path between TECH/ATT did not report statistical significance ( $p > 0.05$ ). Furthermore, the results opposed the importance of attitude towards use in TAM (Davis, Bagozzi, & Warshaw, 1989) since ATT/QoE reported path with  $p > 0.05$ , which was identical to outcomes in the asynchronous learning environment. The data analysis indicated no significant difference among subjects or gender, which correlated with our initial assumption not to include these variables in the proposed model.

## Conclusion and Discussion

Motivated by a need to understand the nature of the high school students participating in distance education environments, the purpose of this study was to identify relevant factors that influence their subjective QoE, while further comparing outcomes during asynchronous and synchronous learning conditions. Even though certain studies have categorized students involved in K–12 environments as “digital natives” (Koutropoulos, 2011; Li & Ranieri, 2010; Prensky, 2001) we moved beyond this concept based on generational differences and assessed high school students as the same as any distance education practitioner in order to obtain conclusions which are specific for this target group. In the course of our research activities, we defined latent constructs measured through a set of observed variables, demonstrated strong measurement structure, and proposed a model that formulated interrelationships among technical performance, students' motivation, attitude, and ease of usage or context (during synchronous or asynchronous activities), while predicting high school students' QoE. Consistent with Somenarain, Akkaraju, and Gharbaran (2010) we found similar behavior in both distance education methods, while the model explained a high percentage of variance in students' QoE (88% in asynchronous and 93% in synchronous learning environments), reflected as students' overall satisfaction, beliefs for natural feeling and enjoyable activity, increased efficiency, and productivity.

Our study revealed that the main determinant of high school students' QoE within asynchronous and synchronous learning environments is students' motivation, especially during asynchronous activities that generally depend on students' own initiative. The high school participants involved in this study demonstrated that intrinsic and extrinsic motivators have regressed positively (with minor preference on intrinsic factors) on overall motivation, while supporting existing studies which highlight that motivation is a complicated, multidimensional inner process, as opposed to a singular, monolithic construct (Chen & Jang, 2010; Ryan & Deci, 2000; Xie, Debacker, & Ferguson, 2006). On the other hand, while literature on TAM stresses the importance of ease of usage for acceptance of new technologies (Davis, Bagozzi, & Warshaw, 1989; Liu et al., 2010), there is research evidence which suggests that perceived ease of use is no longer a crucial factor during asynchronous learning (Lee,

Cheung, & Chen, 2005). Therefore, we made proper distinction and selected ease of usage as an important factor during synchronous learning, since appropriate teacher-student interaction, easiness in following the lessons, and use of videoconferencing equipment correlated positively with high school students' QoE. In like manner, the content played a similar role during asynchronous learning activities, as evident from the outcomes in this study. We also found moderate support between technical performance and students' QoE in both learning methods which correlates with existing studies that provided relations between technical conditions and the quality perceived by end-users from different systems (Khan, Sun, & Ifeachor, 2012; Zapater & Bressan, 2007). However our findings oppose the importance of attitude in TAM or similar acceptance models (Davis, Bagozzi, & Warshaw, 1989; Lee, Cheung, & Chen, 2005), since the high school students instinctively welcomed the new teaching approach and their attitude did not correlate with their subjective QoE.

Although literature abounds on distance education studies that explore the benefits of using emerging technologies, different roles and competencies, proper design of education systems, and so on, the current study involved SEM analysis and a student-centered approach while identifying important factors that can predict positive high school students' QoE in different learning conditions. Even though distance education and technology are closely connected, we tried to abstract the design of educational tools and the technological layer, while focusing on the social behavior and cognitive level of such a learning process. Hence, the results present valuable information to all stakeholders of virtual schools or evolving high schools that try to incorporate distance learning activities, while striving to facilitate student-centered, experiential, effective, and enjoyable environments.

Since this study demonstrated a strong measurement structure, in our further work we will use these constructs, test the model, and attempt to forecast students' QoE in primary, tertiary, and adult distance education, while comparing results against students of varying ages. The current study serves as one of the few attempts to determine factors influencing students' QoE; henceforth, future efforts may use the QoE prediction model and survey additional factors like learning preferences, previous knowledge, cognitive capabilities, and so on, while evaluating the *quality of learning* (QoL) in similar environments.

## References

- Barbour, M. (2011). Today's student and virtual schooling: The reality, the challenges, the promise. *Journal of Open, Flexible and Distance Learning*, 13(1), 5-25.
- Beldarrain, Y. (2006). Distance education trends: Integrating new technologies to foster student interaction and collaboration. *Distance Education*, 27(2), 139-153.
- Bentler, P. M., & Bonett, D. G. (1980). Significance tests and goodness of fit in the analysis of covariance structures. *Psychological Bulletin*, 88(3), 588.
- Bernard, R. M., Abrami, P. C., Borokhovski, E., Wade, C. A., Tamim, R. M., Surkes, M. A., & Bethel, E. C. (2009). A meta-analysis of three types of interaction treatments in distance education. *Review of Educational Research*, 79(3), 1243-1289.
- Bernard, R. M., Abram, P. C., Lou, Y., Borokhovski, E., Wade, A., Wozney, L. et al (2004). How does distance education compare with classroom instruction? A meta-analysis of the empirical literature. *Review of Educational Research*, 74(3), 379-439.
- Bollen, K. A. (1998). *Structural equation models*. John Wiley & Sons, Ltd.
- Byrne, B. M. (2001). Structural equation modeling with AMOS, EQS, and LISREL: Comparative approaches to testing for the factorial validity of a measuring instrument. *International Journal of Testing*, 1(1), 55-86.
- Cavanaugh, C., Gillan, K. J., Kromey, J., Hess, M., & Blomeyer, R. (2004). *The effects of distance education on K-12 student outcomes: A meta-analysis*. Naperville, IL: Learning Point Associates.
- Chang, S. H. H., & Smith, R. A. (2008). Effectiveness of personal interaction in a learner-centered paradigm distance education class based on student satisfaction. *Journal of Research on Technology in Education*, 40(4), 407-426.
- Chen, K. C., & Jang, S. J. (2010). Motivation in online learning: Testing a model of self-determination theory. *Computers in Human Behavior*, 26(4), 741-752.
- Chin, W. W. (1998). Issues and opinion on structural equation modeling. *MIS Quarterly*, 22(1), 7-16.
- Giancola, J. K., Grawitch, M. J., & Borchert, D. (2009). Dealing with the stress of college: A model for adult students. *Adult Education Quarterly*, 59(3), 246-263.



- Colliver, J. A., Conlee, M. J., & Verhulst, S. J. (2012). From test validity to construct validity... and back? *Medical Education*, 46(4), 366-371.
- Cronbach, L. J. (1951). Coefficient alpha and the internal structure of tests. *Psychometrika*, 16(3), 297-334.
- Davis, F.D., Bagozzi, R.P., & Warshaw, P. R. (1989). User acceptance of computer technology: A comparison of two theoretical models. *Management Science*, 35(8), 982-1003.
- Davis, F. D., Bagozzi, R. P., & Warshaw, P. R. (1992). Extrinsic and intrinsic motivation to use computers in the workplace. *Journal of Applied Social Psychology*, 22(14), 1111-1132.
- Donavant, B. W. (2009). The new, modern practice of adult education online instruction in a continuing professional education setting. *Adult Education Quarterly*, 59(3), 227-245.
- Eom, S. B., Wen, H. J., & Ashill, N. (2006). The determinants of students' perceived learning outcomes and satisfaction in university online education: An empirical investigation. *Decision Sciences Journal of Innovative Education*, 4(2), 215-235.
- Gagné, R. M., & Medsker, K. L. (1996). *The conditions of learning: Training applications*. Fort Worth: Harcourt Brace College Publishers.
- Gillies, D. (2008). Student perspectives on videoconferencing in teacher education at a distance. *Distance Education*, 29(1), 107-118.
- Gong, Y., Yang, F., Huang, L., & Su, S. (2009). Model-based approach to measuring quality of experience. In *Emerging Network Intelligence, 2009 First International Conference* (pp. 29-32). IEEE.
- Hair, J. F., Anderson, R. E., Tatham, R. L., & Black, W. C. (1998). *Multivariate data analysis* (5<sup>th</sup> ed.). NY: Prentice Hall International.
- Hardre, P. L., & Reeve, J. (2003). A motivational model of rural students' intentions to persist in, versus drop out of, high school. *Journal of Educational Psychology*, 95(2), 347.
- Helsper, E. J., & Eynon, R. (2010). Digital natives: Where is the evidence? *British Educational Research Journal*, 36(3), 503-520.
- Hew, K. F., & Cheung, W. S. (2010). Use of three-dimensional (3-D) immersive virtual worlds in K-12 and higher education settings: A review of the research. *British Journal of Educational Technology*, 41(1), 33-55.

- Hrastinski, S. (2008). Asynchronous and synchronous e-learning. *Educause Quarterly*, 31(4), 51-55.
- Janowski, L., & Papir, Z. (2009). Modeling subjective tests of quality of experience with a generalized linear model. In *Quality of Multimedia Experience, 2009. QoMEX 2009. International Workshop* (pp. 35-40). IEEE.
- Jaques, D., & Salmon, G. (2012). *Learning in groups: A handbook for face-to-face and online environments*. Routledge.
- Johnson, G. (2008). The relative learning benefits of synchronous and asynchronous text-based discussion. *British Journal of Educational Technology*, 39(1), 166-169.
- Joreskog, K. G., & Sorbom, D. (1984). *LISREL VI user's guide*. Mooresville, IN: Scientific Software.
- Khan, A., Sun, L., & Ifeakor, E. (2012). QoE prediction model and its application in video quality adaptation over UMTS networks. *Multimedia, IEEE Transactions*, 14(2), 431-442.
- Kilkki, K. (2008). Quality of experience in communications ecosystem. *J. UCS*, 14(5), 615-624.
- Kline, R. B. (2005). *Principles and practice of structural equation modeling* (2<sup>nd</sup> ed.). New York: Guilford Press.
- Knoche, H., & Sasse, M. A. (2008). Getting the big picture on small screens: Quality of experience in mobile TV. *Multimedia Transcoding in Mobile and Wireless Networks*, 31-46.
- Koutropoulos, A. (2011). Digital natives: Ten years after. *MERLOT Journal of Online Learning and Teaching*, 7(4), 1-21.
- Laghari, K. U. R., & Connelly, K. (2012). Toward total quality of experience: A QoE model in a communication ecosystem. *Communications Magazine, IEEE*, 50(4), 58-65.
- Lawson, T., Comber, C., Gage, J., & Cullum-Hanshaw, A. (2010). Images of the future for education? Videoconferencing: A literature review. *Technology, Pedagogy and Education*, 19(3), 295-314.
- Lee, M. K., Cheung, C. M., & Chen, Z. (2005). Acceptance of Internet-based learning medium: The role of extrinsic and intrinsic motivation. *Information & Management*, 42(8), 1095-1104.

- Li, Y., & Ranieri, M. (2010). Are 'digital natives' really digitally competent?—A study on Chinese teenagers. *British Journal of Educational Technology*, 41(6), 1029-1042.
- Liu, I. F., Chen, M. C., Sun, Y. S., Wible, D., & Kuo, C. H. (2010). Extending the TAM model to explore the factors that affect intention to use an online learning community. *Computers & Education*, 54(2), 600-610.
- Malinovski, T., Lazarova, M., & Trajkovik, V. (2012). Learner–content interaction in distance learning models: Students' experience while using learning management systems. *Int. J. Innovation in Education*, 1(4), 362–376.
- MacCallum, R. C., Browne, M. W., & Sugawara, H. M. (1996). Power analysis and determination of sample size for covariance structure modeling. *Psychological Methods*, 1(2), 130.
- Murphy, E., & Rodríguez-Manzanares, M. A. (2009). Teachers' perspectives on motivation in high-school distance education. *The Journal of Distance Education/Revue de l'Éducation à Distance*, 23(3), 1-24.
- Murphy, E., Rodríguez-Manzanares, M. A., & Barbour, M. (2011). Asynchronous and synchronous online teaching: Perspectives of Canadian high school distance education teachers. *British Journal of Educational Technology*, 42(4), 583-591.
- Nunnally, J. C., & Bernstein, I. H. (1994). *Psychometric theory* (3<sup>rd</sup> ed.). New York: McGraw-Hill.
- Oblinger, D. G. (2005). Learners, learning & technology: The Educause Learning Initiative. *Educause Review*, 40(5), 66-75.
- Oztok, M., Zingaro, D., Brett, C., & Hewitt, J. (2013). Exploring asynchronous and synchronous tool use in online courses. *Computers & Education*, 60(1), 87-94.
- Powell, A., & Patrick, S. (2006). *An international perspective of K-12 online learning: A summary of the 2006 NACOL International E-Learning Survey*. North American Council for Online Learning.
- Prensky, M. (2001). Digital natives, digital immigrants part 1. *On the horizon*, 9(5), 1-6.
- Robert, L. P., & Dennis, A. R. (2005). Paradox of richness: A cognitive model of media choice. *Professional Communication, IEEE Transactions*, 48(1), 10-21.
- Ryan R. M., & Deci E. L. (2000) Self-determination theory and the facilitation of intrinsic motivation, social development, and well being. *American Psychologist*, 55(1), 68–78.

- Sahin, I., & Shelley, M. (2008). Considering students' perceptions: The distance education student satisfaction model. *Educational Technology & Society, 11*(3), 216-223.
- Smith, R., Clark, T., & Blomeyer, R. L. (2005). *A synthesis of new research on K-12 online learning*. Naperville, IL: Learning Point Associates.
- Somenarain, L., Akkaraju, S., & Gharbaran, R. (2010). Student perceptions and learning outcomes in asynchronous and synchronous online learning environments in a biology course. *MERLOT Journal of Online Learning and Teaching, 6*(2), 353-356.
- Steinweg, S. B., Williams, S. C., & Stapleton, J. N. (2010). Faculty use of tablet PCs in teacher education and K-12 settings. *TechTrends, 54*(3), 54-61.
- Stricker, D., Weibel, D., & Wissmath, B. (2011). Efficient learning using a virtual learning environment in a university class. *Computers & Education, 56*(2), 495-504.
- Tüzün, H., Yılmaz-Soylu, M., Karakuş, T., İnal, Y., & Kızılkaya, G. (2009). The effects of computer games on primary school students' achievement and motivation in geography learning. *Computers & Education, 52*(1), 68-77.
- Zapater, M. N., & Bressan, G. (2007, January). A proposed approach for quality of experience assurance of IPTV. In *Digital Society, 2007, ICDS'07. First International Conference on the* (pp. 25-25). IEEE.
- Xie, K., Debacker, T. K., & Ferguson, C. (2006). Extending the traditional classroom through online discussion: The role of student motivation. *Journal of Educational Computing Research, 34*(1), 67-89.
- Wheaton, B., Muthen, B., Alwin, D., F., & Summers, G. (1977). Assessing reliability and stability in panel models. *Sociological Methodology, 8*(1), 84-136.

Athabasca University 



## To Enhance Collaborative Learning and Practice Network Knowledge with a Virtualization Laboratory and Online Synchronous Discussion



Wu-Yuin Hwang<sup>1</sup>, Chaknarin Kongcharoen<sup>1</sup>, and Gheorghita Ghinea<sup>2</sup>

<sup>1</sup>National Central University, Taiwan, Province of China, <sup>2</sup>Brunel University, United Kingdom

### Abstract

Recently, various computer networking courses have included additional laboratory classes in order to enhance students' learning achievement. However, these classes need to establish a suitable laboratory where each student can connect network devices to configure and test functions within different network topologies. In this case, the Linux operating system can be used to operate network devices and the virtualization technique can include multiple OSs for supporting a significant number of students. In previous research, the virtualization application was successfully applied in a laboratory, but focused only on individual assignments. The present study extends previous research by designing the Networking Virtualization-Based Laboratory (NVBLab), which requires collaborative learning among the experimental students. The students were divided into an experimental group and a control group for the experiment. The experimental group performed their laboratory assignments using NVBLab, whereas the control group completed them on virtual machines (VMs) that were installed on their personal computers. Moreover, students using NVBLab were provided with an online synchronous discussion (OSD) feature that enabled them to communicate with others. The laboratory assignments were divided into two parts: Basic Labs and Advanced Labs. The results show that the experimental group significantly outperformed the control group in two Advanced Labs and the post-test after Advanced Labs. Furthermore, the experimental group's activities were better than those of the control group based on the total average of the command count per laboratory. Finally, the findings of the interviews and questionnaires with the experimental group reveal that NVBLab was helpful during and after laboratory class.

**Keywords:** Virtualization-based laboratory; online synchronous discussion; collaborative learning; teaching networking concepts

## Introduction

A computer networking laboratory provides an opportunity for students to learn how to configure and manage network services. In general, a networking laboratory employs real networking devices to perform experiments but, recently, research has also utilized the Linux operating system (OS) for cost efficiency (Nieh & Vaill, 2005; Sarkar & Lian, 2003) as well as web-based technologies to establish remote access to all devices (Lahoud & Tang, 2006; Summers, Bhagyavati, & Martin, 2005; Wannous & Nakano, 2010). In particular, virtualization-based technology can be used to install a group of virtual machines (VMs) on one server and run OSs on these VMs, also known as guest OSs. Guest OSs enable VMs to be used as hubs, switches, and routers in laboratory classes. Moreover, laboratories that implement virtualization-based technology allow learners to practice on real laboratory devices (Anisetti et al., 2007; Border, 2007; Wannous & Nakano, 2010).

The present study extends previous research that only focused on individual laboratory assignments (Wannous & Nakano, 2010; Wannous, Nakano, Kita, & Sugitani, 2007) by designing the Networking Virtualization-Based Laboratory (NVB Lab). This is based on the online collaborative learning framework (Harasim, 2011), which requires collaborative learning among the students when performing experiments. Further, the purpose of this study is to describe how beneficial the NVB Lab is in students' behavior, perception, and learning achievement.

The students were divided into a control group and an experimental group, and one laboratory experiment was conducted for each group. The experimental group performed their laboratory assignments using NVB Lab, whereas the control group utilized VMs that were installed on their personal computers (PCs). Moreover, students using NVB Lab were provided with an online synchronous discussion (OSD) feature that enabled them to communicate with others as well as their teacher and teaching assistant (TA). This laboratory experiment consisted of Basic Labs (comprising Linux concepts and basic practices) and Advanced Labs (comprising Linux networking and advanced practices). Participants in the control group accomplished all of the assignments in the Basic and Advanced Labs, whereas those in the experimental group completed the assignments in the Basic Labs individually and those in the Advanced Labs as group assignments.

## Related Work

### Theories of Online Collaborative Learning

Previously, collaborative learning activities have only been provided for on-campus students since the limitations of time and space were barriers for off-campus students, especially in collaborative work (Kimball, 1998). However, the introduction of Internet-based collaborative learning systems offers new opportunities for student collaboration, as well as new challenges for teachers supporting such group work (Watabe, Hamalainen, & Whinston, 1995). For instance, various schools and universities have increasingly adopted course management systems (CMS) such as Moodle and Blackboard that provide tools for synchronous and asynchronous online communication. By using them, learners can chat/discuss among themselves as well as participate in group activities. These changes have challenged educators to provide more opportunities for collaboration amongst learners. Therefore, computer-based collaborative learning should become an integral part of the educational strategies of online courses (McAlpine, 2006).

Harasim (2011) proposed the online collaborative learning (OCL) theory, which focuses on three components, namely collaborative learning and knowledge building mediated by the Internet for formal and informal education, working together online to identify and solve problems, and the applications of OCL which refer to web-based technologies such as text-based, multimedia, synchronous, and asynchronous tools.

### Online Synchronous Discussion (OSD)

Recently, OSD capabilities have been provided in a wide range of educational activities. Several studies have illustrated the learning benefits of using OSD. For example, researchers have indicated that the verbal immediacy made possible by OSD develops logical reasoning and critical thinking (Murphy & Collins, 1997), that it improves students' interaction and collaboration (Hew & Cheung, 2003; Kim, 2012; Shana, 2009), and quickly motivates students to achieve the study goal (Kehrwald, 2008). Compared to traditional face-to-face discussions, OSD enables students and teachers to communicate through synchronous text-based messages rather than face-to-face conversations. Also, in a training laboratory, an e-classroom's OSD facilitated effective communication between trainees (Lobel, Swedburg, & Neubauer, 2002). Therefore, OSD can be beneficial for students' learning achievement, especially in text-based activities such as essay writing (Kim, 2012).

### Virtualization-Based Laboratory

Lahoud and Tang (2006) as well as Summers, Bhagyavati, and Martin (2005) have suggested using on-campus, remote-access laboratory facilities. In this manner, learners can access work on real devices and monitor the results achieved on the system.



Recently, this type of remote-access laboratory has been adopted in various computer science courses. However, one disadvantage of this type of laboratory is that it requires a properly installed laboratory facility and additional resources to handle such remote access. Moreover, reconfiguring this type of laboratory requires significant effort from numerous staff members (Abler, Contis, Grizzard, & Owen, 2006).

In related work, Duarte, Butz, Miller, and Mahalingam (2008) proposed using a software simulator within an engineering laboratory. Software simulators include graphical user interfaces (GUIs) that provide learners with a more realistic and enhanced learning experience. The simulator design and its static components (text, pictures, etc.) have proven to be extremely effective for improving the learning capabilities of students. According to recent research, these simulators are designed to emulate hardware laboratory tools and they can easily adapt to certain situations. Additionally, virtual web-based laboratories can interface with software simulators and other software systems (Nieh & Vaill, 2005; Sarkar & Lian, 2003). Furthermore, implementing a laboratory with software simulation can be cost efficient since a simulator can be easily interoperated, especially when coding open-source software. However, one disadvantage of these simulators is that they cannot be implemented to cover all aspects of real laboratory equipment.

As stated earlier, Anisetti et al. (2007), Border (2007), and Wannous and Nakano (2010) introduced virtualization-based technology as a new way of installing a group of VMs on one server and running OSs on these VMs. Moreover, laboratories that implement virtualization-based technology allow learners to conduct experiments on real laboratory devices with flexible and portable features that have been successfully tested and verified for learning purposes. Recently, this virtualization-based laboratory has even been utilized in cloud computing (Chengjun, Quanhong, & Heng, 2012).

## Virtualization Technology in Education

In 2007, IBM published *Virtualization in Education*, which concluded that a virtual computer is a logical representation of a computer in software. By decoupling the physical hardware from the OS, virtualization provides more operational flexibility and increases the utilization rate of the underlying physical hardware. This concept can be applied to devices, servers, OSs, applications, and even networks. Virtualization also has a significant impact on education technology in two major areas. The first area is operational efficiency and related costs, and the second is the academic benefit of improved student performance from allowing student-owned devices to connect to the network.



## Method

### Participants and Procedures

The experiment was conducted during the summer semester (March to May 2013) at Kasetsart University Chalermphrakiat Sakon Nakhon Province Campus, Thailand. The participants in this experiment consisted of a total of 35 undergraduate students enrolled in two sections of an Information Technology and Computer Science (ITCS) class. One section with 15 students served as the control group while the other section with 20 students served as the experimental group.

The procedures of this experiment were based on four overall steps, as shown in Figure 1: 1) pre-test 1 and laboratory orientation; 2) experimental treatment and post-test 1 for the Basic Labs; 3) pre-test 2 and experimental treatment for the Advanced Labs; and 4) post-test 2 and a questionnaire. The experiment was administered twice a week in three-hour increments. The same teacher lectured both groups with the same laboratory topics (Appendix B), which consisted of two parts: Basic Labs (Linux concept and basic practices [Labs 1-3]) and Advanced Labs (Linux networking and advanced practices [Labs 4-6]). In the laboratory class, the experimental group conducted their laboratory assignments using NVB Lab, while the control group performed them on VMs that were installed on their PCs. In the initial class, the teacher informed the experimental group about how to use NVB Lab. In addition, the experimental group was encouraged to use NVB Lab to complete the laboratory and homework assignments as well as to identify the strengths and limitations of NVB Lab.

### Learning Activity Designs

This experiment included learning activities consisting of individual and group assignments, which were designed on the basis of laboratory topics and network equipment. For example, the topics of the Basic Labs and the Advanced Labs were assigned as individual and group activities, respectively. However, since the network equipment of the control group could not support group activity, the Advanced Labs' assignments for this group were created as individual ones. On the other hand, the NVB Lab of the experimental group could be utilized to support group assignments, thus this group could have group activities. Details regarding the designed laboratory class and the homework assignments are described as follows.

**Group laboratory assignment:** The group laboratory assignments consisted of Advanced Labs for the experimental students. The students were divided into groups of five and asked to collaborate with their fellow group members to complete the laboratory assignments within the class period. Again, the experimental students had OSDs with the teacher, TA, and group members using NVB Lab's chat feature. In Lab 4, each experimental student configured a file server, a web server, a database server, a print server, and a FTP server. At the beginning of the assignment, one student

configured one type of server and then explained how to configure the server to the other group members. In Labs 5 and 6, each experimental student managed and configured one of the five routers.

**Individual laboratory assignment:** The individual laboratory assignments consisted of Basic Labs for the experimental students and both Basic and Advanced Labs for the control students. The teacher and TA prepared the laboratory materials and assignments for both student groups. In the beginning of class, the teacher briefed the students about the objective and contents of the experiment and gave the assignments to the students, which were completed by the end of the three-hour class period. The completed assignments were then presented to the teacher and TA for evaluation. In Lab 4 (as shown in Appendix B), each control student configured a file server, a web server, a database server, a print server, and a FTP server, while in Labs 5-6 (as shown in Appendix B), each control student managed and configured three routers. In addition, the control students had face-to-face discussions with the teacher, TA, and classmates. Alternatively, the experimental students had OSDs with the teacher, TA, and their classmates using NVB Lab’s chat feature.

**Homework:** The teacher prepared the same homework assignments for the control group and the experimental group, which consisted of a post-laboratory question aimed at improving the students’ understanding of the experiment. The experimental students were allowed to use NVB Lab to determine the answers from the command manual window and redo the assignments to confirm their answers.

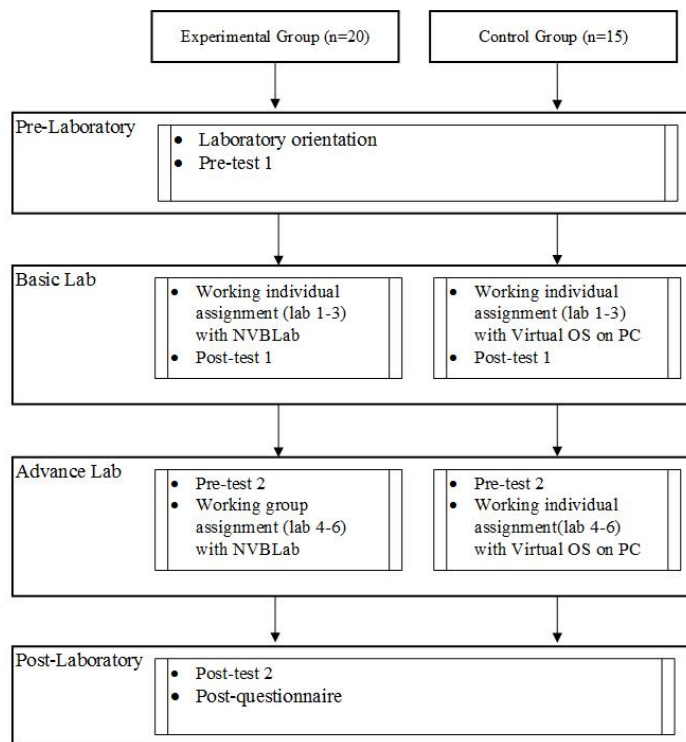

Figure 1. Flow chart for the experiment.

## Research Variables

In this experiment, the following variables related to command count, chat message count, homework scores, pre-test, and post-test were defined. In addition, a comparison of these variables was made between one another as well as with overall learning achievement.

1. **Command count:** The total number of Linux commands coded by a student using NVB Lab for Labs 1-2 and 4-6.
2. **Chat message count:** The total number of chat messages typed by a student using NVB Lab for Labs 1-2 and 4-6 that were relevant to the laboratory assignment.
3. **Homework scores:** The homework scores for Labs 1-6.
4. **Pre-test and post-test:** Pre-tests 1 and 2 are the students' exam scores before the Basic Labs and Advanced Labs, respectively. Post-test 1 is the students' midterm exam scores while Post-test 2 is the students' final exam scores.

## Research Questions

1. What are the students' perceptions and behavioral intentions when using NVB Lab in the computer networking laboratory?
2. When using NVB Lab, do the students perform their assignments (homework and post-test objectives) better than those who do not use NVB Lab?
3. How were the collaborative activities of NVB Lab beneficial to students' learning and what reasons were deduced from the interviews?

## A Networking Virtualization-Based Laboratory: NVB Lab

The structure of NVB Lab includes: a group of guest OSs on one host; a guest OS that operates as a network device; and an administrator who manages NVB Lab via remote access called Virtual-management. A diagram of the system structure is shown in Figure 2.

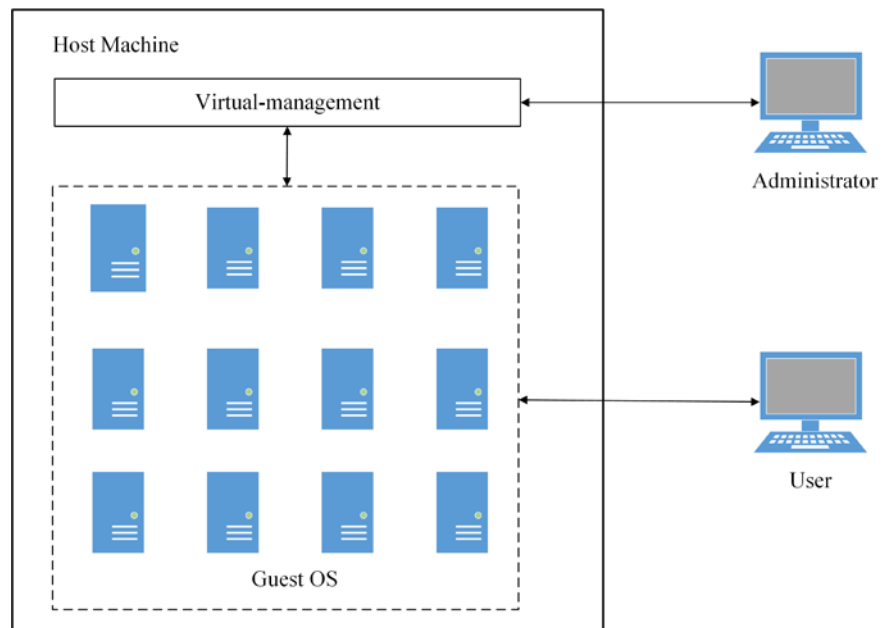

Figure 2. NVBLab structure.

Figure 3 shows that the web GUI is a simple server-side script with a GUI interface that includes the following: 1) a web Linux terminal that allows students to open a command line window on the guest OS; 2) a command search box that enables students to find the command manual; 3) laboratory materials for Labs 1-6; and 4), 5) a chat feature that allows students to have OSDs for sharing Linux and configuration commands with their class members.

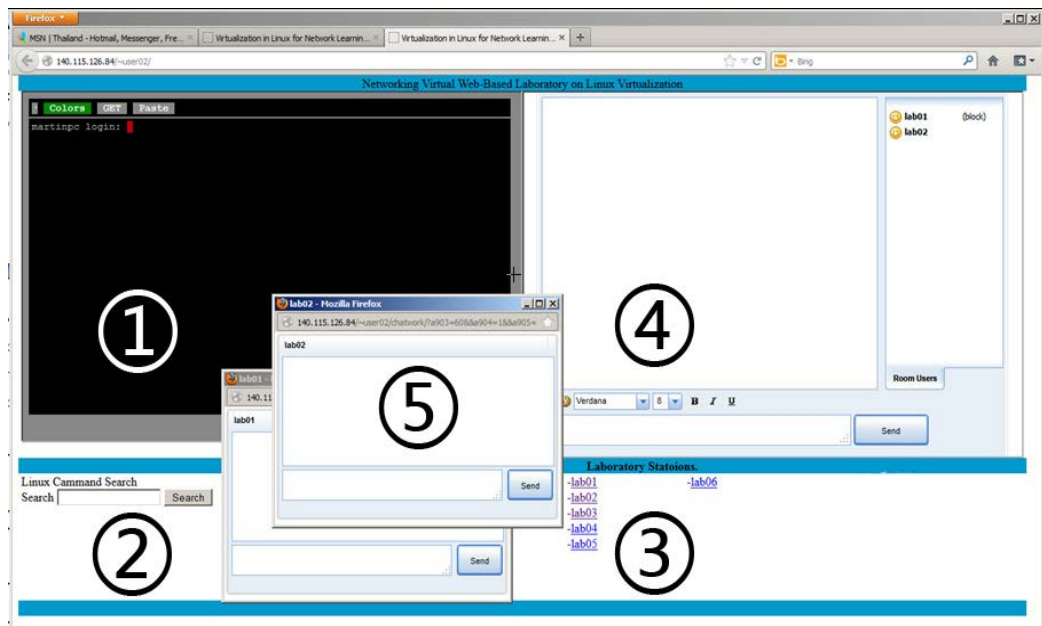

Figure 3. NVBLab Web GUI: 1) Web-terminal; 2) command search window; 3) laboratory materials; and 4), 5) group chat window and individual chat window.

## Results and Discussion

The results of this research and the pedagogical implications are presented in relation to each research question above.

### Students' Perceptions and Behavioral Intentions

A questionnaire survey was conducted in order to investigate the students' perceptions and behavioral intentions. The questionnaire was designed following the technology acceptance model (TAM) (Davis, 1986) and was based on the following four dimensions: 1) perceived ease of NVBLab use; 2) perceived usefulness of NVBLab; 3) attitude toward using NVBLab; and 4) behavioral intentions when using NVBLab. Furthermore, it included five additional dimensions: 1) system characteristics of NVBLab; 2) system accessibility of NVBLab; 3) perceived readiness from using NVBLab; 4) perceived usefulness of NVBLab for collaborative group work; and 5) perceived subjective norm from classmates to use NVBLab. Excluding questions regarding perceived usefulness of NVBLab for collaborative group work and questions number one and two of perceived usefulness of NVBLab for the control group, the responses obtained from the experimental and control groups were ranked using a five-point Likert scale (ranging from *strongly disagree* = 1 to *strongly agree* = 5). The statistical results of the questionnaire survey are presented in Tables 1–9 in Appendix A. According to the *t*-test results, the average mean scores of all the dimensions for the experimental group were higher than

those for the control group. In addition, there were two statistically significant differences regarding system characteristics of NVB Lab ( $t = 2.896$ ,  $p = 0.007$ ) between the experimental group ( $M = 4.67$ ,  $SD = 0.568$ ) and the control group ( $M = 3.778$ ,  $SD = 0.3$ ) and system accessibility of NVB Lab ( $t = 3.267$ ,  $p = 0.878$ ) between the experimental group ( $M = 3.967$ ,  $SD = 0.878$ ) and the control group ( $M = 3.267$ ,  $SD = 0.838$ ). This finding demonstrates three aspects of the experiment. First, the experimental students perceived that they were better prepared for performing laboratory assignments when using NVB Lab and it included good characteristics. Second, the students in the experimental group perceived that NVB Lab provided a Linux OS environment that was more user-friendly than a real networking device. Third, the experimental students confirmed that NVB Lab was easy to access and it offered quick and stable remote access. Moreover, the first four questionnaire dimensions were rated strongly agree and the additional five questionnaire dimensions were rated agree by the experimental group, and all of the questionnaire ratings of this group were higher than those of the control group. This indicates that NVB Lab was ready to be utilized for this particular teaching computer network; NVB Lab was uncomplicated and useful for conducting experiments and collaborative group work; and there was a subjective norm among the students for using and continuing to use NVB Lab in their future studies.

In conclusion, the majority of the questionnaire dimensions were rated either strongly agree or agree, and there were statistically significant differences in the system characteristics of NVB Lab and system accessibility of NVB Lab dimensions. These results strongly imply that system characteristics and accessibility of NVB Lab allow students to have real experiences of laboratory practices through this virtual device (Anisetti et al., 2007; Border, 2007; Wannous & Nakano, 2010). Furthermore, the collaborative learning environment of NVB Lab enhanced the experimental group's perceived collaboration during the laboratory class (McAlpine, 2006).

## T-Test Results of the Pre-Test, Post-Test, and Homework Scores

Pre-test 1 shows no statistically significant difference ( $t = 0.14$ ,  $p = 0.889$ ) between the experimental group ( $M = 3.95$ ,  $SD = 1.76$ ) and the control group ( $M = 3.87$ ,  $SD = 1.68$ ) (see Table 1). In addition, Pre-test 2 shows no statistically significant difference ( $t = -0.418$ ,  $p = .679$ ) between the experimental group ( $M = 2.10$ ,  $SD = 0.72$ ) and the control group ( $M = 2.20$ ,  $SD = 0.68$ ). This indicates that these two groups possessed similar background skills in both the Basic and Advanced Labs.

Next, the analysis of Post-test 1 shows no statistically significant difference ( $t = 0.414$ ,  $p = 0.681$ ) between the experimental group ( $M = 19.15$ ,  $SD = 3.86$ ) and the control group ( $M = 18.60$ ,  $SD = 3.92$ ). However, the analysis of Post-test 2 shows a statistically significant difference ( $t = 2.289$ ,  $p = 0.033$ ) between the experimental group ( $M = 12.15$ ,  $SD = 2.11$ ) and the control group ( $M = 9.53$ ,  $SD = 4.03$ ). This suggests that NVB Lab improved students' learning achievement in the Advanced Labs.

In the Basic Labs, the experimental and control students performed the same individual assignments. Alternatively, in the Advanced Labs, the experimental students worked on group assignments while the control students worked on individual assignments. Since the experimental students participated in and had numerous discussions through chatting, Telnet, SSH, browsing, and group networking configurations, which are activities that tend to impart more knowledge than that gained through individual activities (Stahl, 2006), their learning achievement increased and they outperformed the control students.

Moreover, the results of the homework scores show statistically significant differences in Homework 5 ( $t = 2.448$ ;  $p = 0.023$ ) between the experimental group ( $M = 3.30$ ,  $SD = 0.47$ ) and the control group ( $M = 2.73$ ,  $SD = 0.80$ ) and Homework 6 ( $t = 2.462$ ;  $p = 0.022$ ) between the experimental group ( $M = 3.2$ ,  $SD = 0.52$ ) and the control group ( $M = 2.6$ ,  $SD = 0.83$ ). The results demonstrate that the experimental group improved their learning achievement more than the control group in the final two homework assignments. In addition, the experimental group was able to maintain homework scores that were higher than 3 points, whereas the homework scores of the control group dropped to less than 3 points. The primary reason for this difference is that the experimental students used NVB Lab for collaborative work and support from their group members.

### T-Test Result of the Command Count

There are statistically significant differences regarding command count in Lab 2 ( $t = 6.369$ ,  $p = 0.00$ ) between the experimental group ( $M = 43.70$ ,  $SD = 18.33$ ) and the control group ( $M = 15.40$ ,  $SD = 6.653$ ) and Lab 6 ( $t = 3.033$ ,  $p = 0.006$ ) between the experimental group ( $M = 71.35$ ,  $SD = 10.18$ ) and the control group ( $M = 55.27$ ,  $SD = 18.545$ ). The command count is not related to learning achievement, but it is an indicator of the students' attention. As seen in Table 1, the mean of the laboratory command count of the experimental group was higher than the mean for the control group. This implies that the experimental students did more activities in command practices than the control students. Moreover, the significant differences regarding command count in Labs 2 and 6 show that NVB Lab influenced the experimental students to complete more assignments than the control students.

Table 1

Results of the Assessment and T-Test

Assessment	Control group (n = 15)			Experimental group (n = 20)			F	Sig.	t	df	Sig. (2-tailed)	MD
	Mean	SD	SE	Mean	SD	SE						
Pre-test 1	3.87	1.68	0.43	3.95	1.76	0.39	0.108	0.744	0.141	33	0.889	0.08
Pre-test 2	2.20	0.68	0.17	2.10	0.72	0.16	0.002	0.964	-0.418	33	0.679	-0.10
Post-test 1	18.60	3.92	1.01	19.15	3.86	0.86	0.093	0.773	0.414	33	0.681	0.55
Post-test 2	9.53	4.03	1.04	12.15	2.11	0.47	15.55	0.009	2.289	19.72	0.033*	2.62
Homework 1	4.73	1.03	0.27	4.45	0.60	0.14	0.064	0.802	-1.019	33	0.316	-0.28
Homework 2	3.87	0.52	0.13	4.05	0.60	0.14	0.148	0.703	0.943	33	0.352	0.18
Homework 3	4.20	0.68	0.17	3.65	0.8	0.20	1.561	0.228	-2.021	33	0.051	-0.55
Homework 4	3.13	0.35	0.09	3.10	0.31	0.07	0.355	0.556	-0.298	33	0.767	-0.03
Homework 5	2.73	0.8	0.20	3.30	0.47	0.07	7.670	0.009	2.448	21.17	0.023*	0.57
Homework 6	2.60	0.83	0.21	3.20	0.52	0.12	7.574	0.014	2.462	22.17	0.022*	0.60
Lab 1 Command count	68.87	32.95	8.50	92.25	32.35	07.23	0.000	0.982	2.010	33	0.053	22.383
Lab 2 Command count	15.40	6.653	1.72	43.70	18.33	4.098	15.261	0.000	6.369	25.20	0.000*	28.300
Lab 4 Command count	85.47	38.92	10.05	107.3	49.93	11.16	0.641	0.429	1.402	33	0.17	21.833
Lab 5 Command count	68.27	36.047	9.307	85.50	33.16	7.42	0.014	0.907	1.466	33	0.152	17.233
Lab 6 Command count	55.27	18.545	4.79	71.35	10.18	2.277	10.115	0.003	3.033	20.284	0.006*	16.083

\*p < 0.05



Table 2

*Pearson Correlation Result Between the Post-Test, the Chat Message Count, and the Command Count (n = 20)*

		Command count 1	Command count 2	Command count 4	Command count 5	Command count 6	Post-test 1	Post-test 2
Chat message count 1	Pearson Correlation	-0.109	-0.053	0.135	0.124	0.238	0.499*	0.253
	Sig. (2-tailed)	0.648	0.826	0.569	0.602	0.311	0.025	0.283
Chat message count 2	Pearson Correlation	0.254	0.190	0.189	0.156	0.337	0.657**	0.466*
	Sig. (2-tailed)	0.279	0.422	0.426	0.510	0.146	0.002	0.038
Chat message count 4	Pearson Correlation	-0.206	-0.371	-0.100	-0.130	-0.120	0.023	-0.055
	Sig. (2-tailed)	0.384	0.107	0.674	0.585	0.616	0.922	0.818
Chat message count 5	Pearson Correlation	-0.156	0.119	0.068	0.526*	0.532*	0.408	0.622*
	Sig. (2-tailed)	0.511	0.618	0.776	0.017	0.016	0.074	0.003
Chat message count 6	Pearson Correlation	-0.066	0.267	-0.070	0.453*	0.532*	0.287	0.468*
	Sig. (2-tailed)	0.781	0.255	0.768	0.045	0.016	0.220	0.038
Post-test 1	Pearson Correlation	0.268	0.359	0.345	0.380	0.483*		
	Sig. (2-tailed)	0.253	0.120	0.137	0.098	0.031		
Post-test 2	Pearson Correlation	0.001	0.227	0.176	0.562**	0.558*		
	Sig. (2-tailed)	0.998	0.335	0.457	0.010	0.011		

\*p < 0.05 ; \*\* p < 0.01

### Pearson Correlation Analysis Between the Post-Test, the Chat Message Count, and the Command Count

The results of the Pearson correlation analysis show a significant correlation between the chat message count and the post-test in Lab 1 ( $r = 0.499$ ,  $p = 0.025$ ); 2 ( $r = 0.657$ ,  $p = 0.002$ ); 5 ( $r = 0.622$ ,  $p = 0.003$ ); and 6 ( $r = 0.468$ ,  $p = 0.038$ ), the post-test and the command count in Lab 5 ( $r = 0.562$ ,  $p = 0.01$ ) and 6 ( $r = 0.558$ ,  $p = 0.011$ ), and the command count and chat message count in Lab 5 ( $r = 0.526$ ,  $p = 0.017$ ) and 6 ( $r = 0.532$ ,  $p = 0.016$ ). Firstly, the significant correlations between the post-test and chat message count in Labs 1, 2, 5, and 6 show that OSDs can be beneficial for students' learning performance, especially in text-based activities (Hou, Chang, & Sung, 2008; Kim, 2012). The experimental students, when inputting Linux commands, usually worked in both

the web terminal and the chat message window. As a result, they received immediate feedback and support from other class members. Secondly, the significant correlations between the post-test and the command count in Labs 5 and 6 show that when the experimental students do more activities in the same assignments with control students in the Advanced Labs, they increase their learning performance. Finally, there were significant correlations between the command count and the chat message count in Labs 5 and 6. These indicate that the experimental students actively collaborate to do these two laboratory assignments that are caused by OSD providing a useful communication to exchange understanding. As a consequence, they get more command count (Holliman & Scanlon, 2006). In addition, in Labs 5 and 6, both chat message and command count positively and significantly influence the achievement. Therefore, the experimental students complete more assignments and have more interaction like chatting and using command, and they can get a higher level of learning achievement.

## Interview and In-Depth Investigation

During the one-on-one semi-structured interviews, the students mentioned that they could benefit from using NVB Lab for experiments in class as well as homework. Regarding the use of NVB Lab for experiments, the students pointed out a technical issue in which the virtualization OS was defective due to student error or unstable OS software. Since this occurred occasionally throughout the experiment, the students had to change to another virtualization OS in order to complete the assignment (Nieh & Vaill, 2005). The following content was extracted from two different interviews:

In Lab 3, I installed Linux OS several times but the OS did not run. Therefore, I could not finish the lab assignment on time. After the teacher allowed me to use NVB Lab, I was able to continue the assignment and finish it 30 minutes after the class period.

Due to problems with the Linux configuration, I performed some configurations by following the lab sheets, but I still could not complete the assignments. Moreover, other group members helped me with the configurations but it still did not work. Finally, after the TA created a new Linux OS in NVB Lab, I was able to finish the assignment on time.

In addition, students preferred conducting the experiment by chatting with other group members in NVB Lab. The reason for such behavior was that the students wanted to determine the correct network configuration and commands with their class members. Therefore, the teacher guided the students to utilize the chat feature and the students were able to easily follow the teacher to complete the experiment (Mason, 1991; Muirhead, 2000). Moreover, the students also mentioned that NVB Lab and the web-based terminal was easy to use. The following content is derived from two different interviews:

During the laboratory class, I often used NVB Lab to chat with other group members, the TA and the teacher. I obtained the IP numbers from my group members because it was difficult to remember them from our conversation since there were so many to configure for the assignment.

I always received extra commands that were not included on the lab sheets. This was very helpful for me and my group members. I could just copy and paste the data directly from my chat window. For the lab assignments, we were required to create a new network design. So the teacher and TA guided us by sending the correct commands.

Regarding the use of NVB Lab's command search window, the students queried Linux commands in the window in order to construct commands and special networking configurations such as long commands, special IPs, and router commands. The following content is extracted from two different interviews:

NVB Lab gave me a Linux command description in the Thai language, which was very helpful for me. In this way, I no longer need to find the command comparisons in the Linux manual that have long command descriptions in English.

During the network configuration part of the lab, there was no routing command in the Linux manual. However, NVB Lab's command search window gave us a clear command description. The teacher and TA then prepared the suitable routing command description for us to apply.

## Implications Regarding Education and Technology

Based on the findings, this study presents the following implications and recommendations for educators who plan to teach in a Linux networking virtualization-based laboratory. Firstly, it recommends using NVB Lab to enhance students' understanding of laboratory content as well as applying such technology both during and after the lectures. Secondly, NVB Lab is a collaborative learning environment in which educators and students can have direct and immediate conversations via a chat feature. In addition, educators can simultaneously monitor students in class and help them correct certain configurations by sending messages. Therefore, this collaborative chat feature increases students' attention to perform assignments during laboratory class. Thirdly, since the students' behaviors during the Basic and Advanced Labs differed when working on the assignments, educators need to communicate more via

online discussions during the Basic Labs, especially since students are generally unfamiliar with new procedures. Alternatively, in the Advanced Labs (group assignments), the students had many discussions with their group members. Thus, educators should use online discussions to communicate with their class via the chat feature, especially for giving guideline commands. Fourthly, this experiment recommends that educators prepare and evaluate the lab sheets for their students in order to ensure that they are correct. In this regard, incorrect lab sheets can prevent students from completing the assignments within the class period, which can affect their acceptance of the proposed system. This is especially important during the Advanced Labs.

Finally, this experiment shows that NVB Lab can be a cost-efficient laboratory solution compared to the cost of buying high-profile networking equipment directly from the manufacturers. However, the number of guest OSs which will install in the host machine is limited; it depends on the host capability. Previous research allowed one user to work on the virtualization laboratory to do one assignment at one time (Abler, Contis, Grizzard, & Owen, 2006; Wannous & Nakano, 2010). Conversely, in this research study we allowed all students to work during the same time period because we assigned each student with one guest OS. After that the guest OS of each student could connect to the guest OS of other group members to establish a networking topology of collaborative assignments and to have discussions. Furthermore, if educators apply the Linux OS to teach networking, then students will gain experience both in networking and Linux (Unix-based), which is currently the most popular OS for Android, IOS, and Mac OS, thus providing students with the basis to further obtain much sought-after skill sets.

## Conclusion

This experiment applied NVB Lab with OSD capabilities for a computer networking laboratory class in order to determine its effectiveness on learning performance. In addition, it investigated the students' perceptions and behavioral intentions when using NVB Lab. First of all, it successfully deployed a virtualization technique into a computer networking laboratory class. This technique allowed the instructor to create a variety of virtual networking topologies for laboratory class. Therefore, the students can learn with real networking experience. The students accepted NVB Lab for performing the assignments during and after class. In addition, NVB Lab was especially beneficial for group assignments since the OSD feature allowed the students to interact and share knowledge with other group members as well as the teacher and TA. Based on the findings, the OSD feature was a key factor for helping students complete the laboratory tasks within the class period. Overall, this virtualization technique proved to be an optimal method for virtual networking laboratory infrastructure.

There are several limitations that need to be acknowledged regarding this experiment. The first limitation is the relatively small sample size, which limits the broad

generalization of the results. Therefore, in the future, this study will increase the sample size in both the control and experimental groups. Another limitation is the adoption of NVB Lab by the teacher and TA, which requires additional time to prepare the system before or after class. Finally, for future development, efforts should include adding other types of tablet compatibility and screen sharing as well as a time recording and logging system.

## References

- Abler, R. T., Contis, D., Grizzard, J. B., & Owen, H. L. (2006). Georgia tech information security center hands-on network security laboratory. *Education, IEEE Transactions*, 49(1), 82-87.
- Anisetti, M., Bellandi, V., Colombo, A., Cremonini, M., Damiani, E., Frati, F., . . . Rebecani, D. (2007). Learning computer networking on open paravirtual laboratories. *Education, IEEE Transactions*, 50(4), 302-311.
- Border, C. (2007). The development and deployment of a multi-user, remote access virtualization system for networking, security, and system administration classes. *SIGCSE Bull.*, 39(1), 576-580.
- Chengjun, X., Quanhong, T., & Heng, Z. (2012, 14-17 July 2012). *A research of safety mechanism in cloud computing platform based on virtualization*. Paper presented at the Computer Science & Education (ICCSE), 2012 7th International Conference.
- Davis, Jr, F. D. (1986). *A technology acceptance model for empirically testing new end-user information systems: Theory and results*. Massachusetts Institute of Technology.
- Duarte, M., Butz, B. P., Miller, S. M., & Mahalingam, A. (2008). An intelligent universal virtual laboratory (UVL). *Education, IEEE Transactions*, 51(1), 2-9.
- Harasim, L. (2011). *Learning theory and online technologies*. Routledge.
- Hew, K. F., & Cheung, W. S. (2003). Evaluating the participation and quality of thinking of pre-service teachers in an asynchronous online discussion environment: Part 1. *International Journal of Instructional Media*, 30(3), 247-262.
- Holliman, R., & Scanlon, E. (2006). Investigating cooperation and collaboration in near synchronous computer mediated conferences. *Computers & Education*, 46(3), 322-335.
- Hou, H.-T., Chang, K.-E., & Sung, Y.-T. (2008). Analysis of problem-solving-based online asynchronous discussion pattern. *Educational Technology & Society*, 11(1), 17-28.
- IBM. (2007). *Virtualization in education*. IBM Global Education White Paper. Retrieved from <http://www-07.ibm.com/solutions/in/education/download/Virtualization%20in%20Education.pdf>
- Kehrwald, B. (2008). Understanding social presence in textbased online learning environments. *Distance Education*, 29(1), 89-106.

- Kim, I.-H. (2012). Development of reasoning skills through participation in collaborative synchronous online discussions. *Interactive Learning Environments* (ahead-of-print), 1-18.
- Kimball, L. (1998). Managing distance learning — New challenges for faculty. In R. Hazemi, S. Hailes & S. Wilbur (Eds.), *The digital university* (pp. 25-38). Springer London.
- Lahoud, H. A., & Xin Tang, P. (2006). *Information security labs in IDS/IPS for distance education*. Paper presented at the Proceedings of the 7th conference on Information technology education, Minneapolis, Minnesota, USA.
- Lobel, M., Swedburg, R., & Neubauer, M. (2002). The eClassroom used as a teacher's training laboratory to measure the impact of group facilitation on attending, participation, interaction, and involvement. *The International Review of Research in Open and Distance Learning*, 3(2).
- Mason, R. (1991). Analyzing computer conferencing interaction. *International Journal of Computers in Adult Education and Training*, 2(3), 161-173.
- McAlpine, I. (2000). Collaborative learning online. *Distance Education*, 21(1), 66-80.
- Muirhead, B. (2000). Interactivity in a graduate distance education school. *Educational Technology & Society*, 3(1), 2000.
- Murphy, K. L., & Collins, M. P. (1997). Communication conventions in instructional electronic chats. *First Monday*, 2(11).
- Nieh, J., & Vaill, C. (2005). Experiences teaching operating systems using virtual platforms and linux. *SIGCSE Bull.*, 37(1), 520-524.
- Sarkar, N. I., & Lian, J. H. (2003, 9-11 July 2003). *LAN-designer: A software tool for teaching and learning LAN design*. Paper presented at the Advanced Learning Technologies, 2003. Proceedings. The 3rd IEEE International Conference.
- Shana, Z. (2009). Learning with technology: Using discussion forums to augment a traditional-style class. *Educational Technology & Society*, 12(3), 214-228.
- Stahl, G. (2006). *Group cognition: Computer support for building collaborative knowledge. Acting with technology series*. MIT Press.
- Summers, W. C., Bhagyavati, & Martin, C. (2005). *Using a virtual lab to teach an online information assurance program*. Paper presented at the Proceedings of the 2nd annual conference on Information security curriculum development, Kennesaw, Georgia.

Wannous, M., & Nakano, H. (2010). NVLab, a networking virtual web-based laboratory that implements virtualization and virtual network computing technologies. *Learning Technologies, IEEE Transactions on*, 3(2), 129-138.

Wannous, M., Nakano, H., Kita, T., & Sugitani, K. (2007). *A core system for a web-based virtual computer laboratory*. Paper presented at the Proc. Eighth Int'l Conf. Information Technology in Higher Education and Training.

Watabe, K., Hamalainen, M., & Whinston, A. B. (1995). An internet based collaborative distance learning system: Codiless. *Computers & Education*, 24(3), 141-155.



## Appendix A

### Questionnaire Survey

**Table 1 System Characteristics of NVB Lab.**

#	Item	Group	Item Mean	Dimension Mean	SD	t	Sig. (2-tailed)
1	I think that the proposed system can provide a real Linux networking environment as a working in real machine.	Experimental	4.50	4.267	0.568	2.896	0.007*
		Control	4.47	3.778	0.30		
2	I think that the proposed system have good facilitates.	Experimental	4.10	*p < 0.05			
		Control	3.80				
3	I think that the proposed system have helpful peer and tutor support.	Experimental	4.20				
		Control	4.33				

**Table 2 System Accessibility of NVB Lab.**

#	Item	Group	Item Mean	Dimension Mean	SD	t	Sig. (2-tailed)
4	I have no difficulty accessing and using this system.	Experimental	3.95	3.967	0.878	2.380	0.023*
		Control	3.87	3.267	0.838		
5	I think that I can remote to this system is stable in every place.	Experimental	4.05	*p < 0.05			
		Control	3.93				
6	I think that I can access to this system faster and smoothly.	Experimental	3.90				
		Control	3.53				

**Table 3 Perceived Readiness from using NVB Lab.**

#	Item	Group	Item Mean	Dimension Mean	SD	t	Sig. (2-tailed)
7	I always peer review laboratory contents on the proposed system before class.	Experimental	3.75	3.933	0.547	0.299	0.700
		Control	3.67	3.844	0.805		
8	I think that our educational (style) culture in class is ready for the proposed system.	Experimental	4.00	*p < 0.05			
		Control	3.93				
9	I think that the proposed system make student ready to do lab assignments.	Experimental	4.05				
		Control	3.93				

**Table 4 Perceived Usefulness of NVB Lab for Collaborative Group work.**

#	Item	Group	Item Mean	Dimension Mean	SD	t	Sig. (2-tailed)
10	I would like to collaborate with class mates in the same group for doing lab assignments.	Experimental	4.50	4.325	0.52	-	-
		Control	-	-	-		
11	I would like to collaborate with class mates in another group for doing lab assignments.	Experimental	4.05	*p < 0.05			
		Control	-				
12	I would like to share network configuration and topology with group members for doing lab assignments.	Experimental	4.30				
		Control	-				
13	From my experience, "collaboration" among classmates usually succeeds to finish assignment faster.	Experimental	4.45				
		Control	-				

**Table 5 Perceived Subjective Norm from Classmates to Use NVB Lab.**

#	Item	Group	Item Mean	Dimension Mean	SD	t	Sig. (2-tailed)
14	Most people who are important to me think that it would be fine to use this system to do lab assignments.	Experimental	4.20	4.133	0.534	1.061	0.244
		Control	4.33	3.889	0.763		
15	Most people who are important to me would be in favor of using this system to do lab assignments.	Experimental	4.20	*p < 0.05			
		Control	4.13				
16	I think other students in my classes would be willing to use this system.	Experimental	4.00				
		Control	3.20				

Table 6 Perceived Ease of NVBLab use.

#	Item	Group	Item Mean	Dimension Mean	SD	t	Sig. (2-tailed)
17	I think that the proposed system is very convenient to do lab assignments.	Experimental	4.05	3.850	0.455	1.140	0.268
		Control	4.00	3.567	0.879		
18	I think that the operation of the proposed system does not require too much time.	Experimental	4.05	*p < 0.05			
		Control	3.93				
19	I think that the proposed system is very easy to do practical lessons and exercises after class.	Experimental	3.80				
		Control	3.73				
20	I feel that learning to use this system is quite easy.	Experimental	3.60				
		Control	2.60				

Table 7 Perceived Usefulness of NVBLab.

#	Item	Group	Item Mean	Dimension Mean	SD	t	Sig. (2-tailed)
21	I think that the chat windows can communicate with other group members to have suggestions for accomplishing lab assignments.	Experimental	4.35	4.275	0.525	0.324	0.748
		Control	-	4.200	0.841		
22	I think that the sharing of chat window is useful for doing lab assignments.	Experimental	4.30	*p < 0.05			
		Control	-				
23	I think that the proposed system increase collaborative work with other group members when do lab assignments.	Experimental	4.30				
		Control	4.20				
24	I think that the proposed system enhance my attention.	Experimental	4.25				
		Control	4.20				

Table 8 Attitude toward using NVBLab.

#	Item	Group	Item Mean	Dimension Mean	SD	t	Sig. (2-tailed)
25	I like using this system to learn networking.	Experimental	4.20	4.267	0.525	0.799	0.430
		Control	4.07	4.111	0.626		
26	I have a positive attitude toward using this system.	Experimental	4.20	*p < 0.05			
		Control	4.13				
27	I feel that using this system to do lab assignments is a good method.	Experimental	4.40				
		Control	4.14				

Table 9 Behavioral Intentions when using NVBLab.

#	Item	Group	Item Mean	Dimension Mean	SD	t	Sig. (2-tailed)
25	If I have access to this system, I will use it to learn networking.	Experimental	4.25	4.150	0.129	1.391	0.174
		Control	3.93	3.778	0.258		
26	If I do lab assignments, I will enjoy doing with this system.	Experimental	4.30	*p < 0.05			
		Control	4.13				
27	I think that I will use this system to help me when I do my homework.	Experimental	3.90				
		Control	3.27				

## Appendix B

### Topic of Laboratory Assignment

#### **Basic Labs: Linux concepts and basic practices**

Lab1 Introduction to Linux and Linux command

Lab2 Linux Script

Lab3 Install Linux

#### **Advance Labs: Linux networking and advance practices**

Lab4 Linux Networking, Configuration

Lab5 Linux Networking, Static Routing

Lab6 Linux Networking, Dynamic Routing

# Appendix C

## Network topology of Linux Networking, Configuration: Lab4

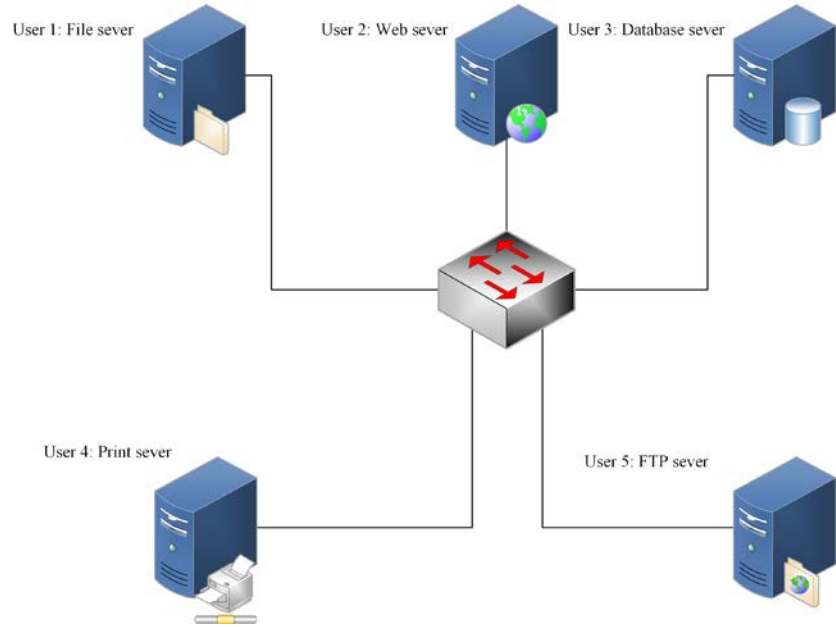

## Appendix D

### Network Topology of Networking, Static Routing, and Dynamic Routing: Lab5 and Lab6

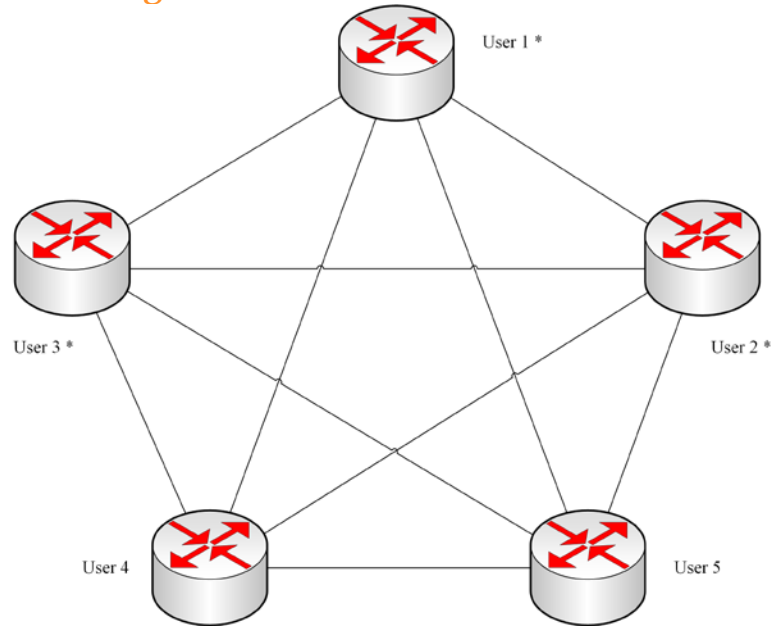

\* The control group has to configure only 3 routers.

Athabasca University 



## Crowdteaching: Supporting Teaching as Designing in Collective Intelligence Communities

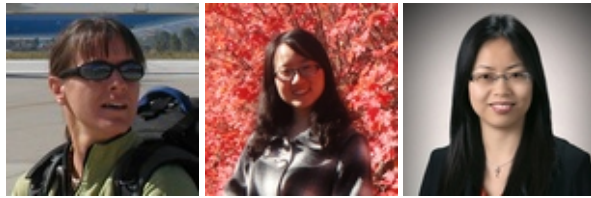

Mimi Recker<sup>1</sup>, Min Yuan<sup>1</sup>, and Lei Ye<sup>2</sup>

<sup>1</sup>Utah State University, USA, <sup>2</sup>Pacific Northwest University of Health Sciences, USA

### Abstract

The widespread availability of high-quality Web-based content offers new potential for supporting teachers as designers of curricula and classroom activities. When coupled with a participatory Web culture and infrastructure, teachers can share their creations as well as leverage from the best that their peers have to offer to support a collective intelligence or crowdsourcing community, which we dub *crowdteaching*. We applied a collective intelligence framework to characterize crowdteaching in the context of a Web-based tool for teachers called the Instructional Architect (IA). The IA enables teachers to find, create, and share instructional activities (called IA projects) for their students using online learning resources. These IA projects can further be viewed, copied, or adapted by other IA users. This study examines the usage activities of two samples of teachers, and also analyzes the characteristics of a subset of their IA projects. Analyses of teacher activities suggest that they are engaging in crowdteaching processes. Teachers, on average, chose to share over half of their IA projects, and copied some directly from other IA projects. Thus, these teachers can be seen as both contributors to and consumers of crowdteaching processes. In addition, IA users preferred to view IA projects rather than to completely copy them. Finally, correlational results based on an analysis of the characteristics of IA projects suggest that several easily computed metrics (number of views, number of copies, and number of words in IA projects) can act as an indirect proxy of instructionally relevant indicators of the content of IA projects.

**Keywords:** Distributed learning environments; evaluation of CAL systems; interactive learning environments; pedagogical issues

## Introduction

Teachers have long been designing and modifying curricula and lesson plans (Ball & Cohen, 1996; Brown & Edelson, 2003; Fogleman, McNeil, & Krajcik, 2011; Remillard, 2005). More recently, this phenomenon, called teachers as designers, has drawn renewed interest (e.g., Davis & Varma, 2008), prompted in part by the widespread availability of high-quality online resources, called open educational resources (OER), via the Internet. As OER become increasingly and widely available, research is needed to understand how teachers design curricula, lesson plans, and classroom activities using such resources. In particular, in networked computing environments that provide easy sharing and reuse, how do teachers become engaged in designing, sharing, and modifying instructional artifacts, and do these activities impact their resulting quality?

Our approach for supporting teachers as designers is via a free, Web-based authoring tool called the Instructional Architect (IA.usu.edu), which enables teachers to find and design instructional activities for their students using OER (Recker, 2006). Teachers can share these resulting activities, called IA projects, by making them publically available within the IA. These IA projects can then be viewed, copied, or adapted by other IA users to further support their own teaching activities (Recker et al., 2005; Recker et al., 2007). Viewed in this way, the IA provides an infrastructure for collective intelligence and crowdsourcing, which we dub crowdteaching, in which teachers can create, share, and iteratively adapt instructional activities using OER, leveraging from their peers' work to best serve the needs of their students (Benkler, 2006; Borgman et al., 2008; Porcello & Hsi, 2013).

In collective intelligence communities, loosely organized groups of people connected by the Internet work together to accomplish tasks in ways that appear more intelligent, more effective, and more efficient than working alone (Malone, Laubacher, & Dellarocas, 2009). However, studies of collective intelligence sites, such as Wikipedia, suggest that these peer production models may succeed only when they are aimed at focused tasks and coupled with incentives to harness the work of the best contributors (Malone et al., 2009). Thus for crowdteaching models to succeed, we need more nuanced understandings of how teachers can participate in such environments to create and share instructional activities around OER.

The purpose of this exploratory article is to explore how teachers' activities within the IA may reveal crowdteaching processes. We first provide an overview of the IA system, and then describe how it fits within a framework for examining collective intelligence communities. Next, we examine the usage and creation activities of two teacher samples and analyze the characteristics of a subset of IA projects implemented by teachers in classrooms. In this way, we explore what aspects of these teachers' design activities may enhance the collective intelligence of the IA community and the nature of the artifacts that are produced.

## Collective Intelligence Context: The Instructional Architect

The collective intelligence context for this work is the Instructional Architect (IA.usu.edu), in use since 2001. The IA is a free, easy-to-use Web-based authoring tool that enables teachers to easily find and assemble OER into learning activities for their students (Recker, 2006). The IA was originally designed for K-12 teachers, and has been widely used in various subject areas (e.g., art, engineering, math) by teachers in both K-12 and higher education settings.

To support teachers' design and collaboration activities, the IA offers several functions. For example, the "My Resources" area allows teachers to search for and save OER to their personal collections. The "My Projects" area allows teachers to create IA projects using collected OER, and publish (or share) these IA projects. From the perspective of collaboration, teachers can view published IA projects by using the "search" function, and copy their favorite ones to their personal collection. In this way, the IA supports crowdteaching processes in that teachers can create and contribute IA projects, as well as view, copy, and build upon other teachers' IA projects that have been contributed to the IA community.

Since 2005, the IA has attracted over 7,600 registered users, who have gathered approximately 74,000 OER and created over 17,300 IA projects. Since August 2006, public IA projects have been viewed over 2.5 million times. These IA projects address a range of subject areas and grade levels, rely on a range of pedagogies, and incorporate varying numbers of OER in many different ways.

Figure 1 shows an example IA project created by a middle school science teacher. In this example, the teacher has written text that presents a problem, as well as supporting information to help solve the problem. This information includes a link to an online simulation that helps students learn what variables affect density. Here, the OER is included as a support to the primary problem solving activity.

Figure 2 shows a simpler IA project on a science-related topic for 8th grade students. In this example, the teacher directs students to a link, while asking them to complete a worksheet. In this case, the OER plays the major role in instruction.



**Problem Presentation:**  
 You and your friends have been camping. As you leave the camp site, you discover a very large tree has fallen on the trail. It is too large to climb over or go around. So, you take a different route, which leads you to a large lake. The only way to get to the other side is to go across it. Since there are no rafts around, you realize you will need to build one. You see around you: bricks, logs, long, thick tree branches, metal tent poles, and shovels. Last year you learned about density and what helps objects float. You now need to figure out what objects will float and how density works.



**Current Knowledge:**  
 What are some things you already know about density in order to solve this problem? How could this information help you solve the problem about building a raft?

**Information Sources:**  
 You will need to gather more information about density so you can solve the problem of building the raft. Click on the link to discover more about density. [Interactive Density Game](#)

Continue with the next website that will give you more information about what density it and how to calculate density. [Calculating Density Interactive Page](#)

**Information Seeking:**  
 You should now have enough information to solve the problem with your friends at the lake and be able to build a raft. However, if you would like to read more about density on your own, you may do your own internet search. You can either use Google, or open another tab use a search engine of your choice. [Google website](#)

**What Have You Learned?**  
 At the start of this website, you were asked what you already know about density. I would like you to now share what you have learned about density by doing this activity.

What did you not know about density before that you know now?  
 What resource helped you best understand what density is?  
 Do you feel you have a better understanding of what density is?

**Solution:**  
 Your job now is to describe the best solution to the problem about building a raft. What materials are best to use and why? Are there objects that should NOT be used? Carefully explain your solution and why that is the best solution for this problem.

**Reflection:**  
 How did this activity better help you understand density?  
 Were you able to come up with a reasonable solution to the problem?  
 Explain how this activity will help you remember density in the future.

Figure 1. Example of an inquiry-based IA project.



## Forces of Motion

Answer the questions on a sheet of paper

<http://teachertech.rice.edu/Participants/louviere/Newton/>

Figure 2. Example of an IA project with minimal text and a link to one OER.

## Theoretical Framework

In this section, we first review a framework for characterizing collective intelligence communities and show how it applies to crowdteaching in the context of the Instructional Architect. We then describe two indicators for examining and characterizing the content of teachers' IA projects.

### Collective Intelligence

In a recent paper, Malone et al. (2009) analyzed over 250 examples of online collective intelligence and crowdsourcing communities, using two sets of related questions. The first set of questions examines “what,” that is, the goals or outcomes of the collective intelligence community. For example, key activities may involve creating artifacts or deciding on winners. These questions also address the primary processes behind these activities, for example, collecting or collaborating.

The second set of questions addresses “who” is engaged in tasks. In a collective intelligence community, either an egalitarian crowd or a hierarchy (where some participants have more decision-making power than others, e.g., editors in Wikipedia) performs the tasks. These questions also address “why,” or user motivations and incentives for engaging in tasks. In some cases, money may be the motivator. For example, in TeachersPayTeachers.com, teachers post lesson plans and activities that then can be purchased and revised by others (Abramovich & Schunn, 2012). In other communities, however, altruism is a key driver. In the Tapped In online community, for example, educational professionals engaged in mentoring and discussions with no concrete reward structures (Farooq, Schank, Harris, Fusco, & Schlager, 2007).

Table 1

*Create and Decide Dimensions from Malone et al. (2009) Applied to the Instructional Architect*

	What	Who	Why	How
Create	IA project	Teachers, individually	Motivate students; supplant and supplement textbook; increase efficiency	Create personal collection of IA projects
Decide	View IA project	Teachers, individually	Leverage wisdom of crowd, learn from peers and OER	View public IA projects
Decide	Copy IA project	Teachers, individually	Leverage wisdom of crowd, improve efficiency and effectiveness	Copy public IA projects to personal collection

Following the framework of Malone et al. (2009), Table 1 shows key create and decide dimensions in the IA in terms of “what is being accomplished (goal),” “who is performing the task,” “why they are doing it (incentives),” and “how it is done.” For the create dimension in the IA, teachers work independently to design IA projects. As reported elsewhere, we have found that key motivations for teachers in using the IA include the desire to increase student motivation by using interactive content, to supplement their textbook materials, to increase student understanding using interactive resources, and to increase their efficiency as teachers (Recker et al., 2005; Recker et al., 2007). Teachers accomplish these tasks by creating a collection of IA projects, which they can then choose to share with only their students or with anyone using the IA site.

In the decide dimension in the IA, teachers can individually decide to view or copy an existing IA project from the public collection. For example, a teacher might decide to search for and view IA projects on a particular topic to see how other teachers are choosing to teach it and what OER they are using to support student learning. This approach might be more efficient than an unconstrained search of the Internet, which many teachers find highly inefficient (Mardis, El Basri, Norton, & Newsum, 2012). It might also be more effective in that teachers can learn from other teachers and from the content of the OER they select (Ball & Cohen, 1996; Davis & Krajcik, 2005; Drake & Sherin, 2006). If teachers especially like an IA project, they can decide to copy it to their personal collection for further editing, adaptation, and reuse.

## Examining and Characterizing Artifact Content

A key objective of the collective intelligence process is to leverage the work of others to improve the effectiveness and/or efficiency of creating artifacts. In education, the rapid rise of repositories of OER, such as those provided by TeacherTube, the National Science Digital Library (NSDL.org), the Khan Academy, the OER Commons, and OpenCourseWare (Atkins, Brown, & Hammond, 2007), has made evaluating the content of OER more pressing (Sumner, Khoo, Recker, & Marlino, 2003; Kastens et al., 2005; Porcello & Hsi, 2013).

Characterizing the content of OER, however, has proven a complex task. Multiple factors can impact a person’s judgment, such as an OER’s availability, credibility, currency, and authority of the content, and the context (e.g., pedagogy, setting) of use of an OER (Custard & Sumner, 2005; Leary, Giersch, Walker, & Recker, 2009; Wetzler et al., 2013). In this work, we adopted strategies used in previous work that assessed teachers’ naturally occurring artifacts (e.g., lesson plans) as a means to measure the quality of students’ learning opportunities (Penuel & Gallagher, 2009). Thus, we examined the content of artifacts created by teachers (i.e., IA projects) using two sets of instructionally relevant indicators. These indicators are described next.

**Indicator 1: Problem-based learning (PBL).** We applied a rubric developed in previous research (Walker et al., 2012) to score an IA project’s alignment with a form of inquiry

learning, specifically problem-based learning (Barrows, 1996). The rubric consisted of 11 elements in four categories (Authentic Problem, Learning Processes, Facilitator, and Group Work), with the presence of each element rated on a 0–2 scale, resulting in a maximum possible score of 22 points. Three raters, randomly selected from a pool of five raters, independently scored the PBL alignment of the IA projects. Overall inter-rater reliability of the rubric as measured by average one-way random effects intra-class correlation (ICC) was high, with  $ICC = .86$  (Walker et al., 2012).

Indicator 2: Offload-adaptation-improvisation (OAI). As an outcome of studying teachers' adaptation of an innovative curriculum, Brown and Edelson (2003) devised the design capacity for enactment (DCE) framework within a “teaching as design” paradigm. As part of the framework, they defined a continuum of curriculum use, ranging from offloads to adaptations to improvisations. This continuum describes the distribution of responsibility for instruction between the teacher and the curriculum. In particular, in offloads, the curriculum is implemented essentially unchanged and the bulk of instructional decisions are contained in the instructional materials. In improvisation, the teacher flexibly borrows and customizes pieces while playing a major role in the decision-making process. The adaptation category represents the midpoint of the continuum.

Building on our previous work (Recker et al., 2007), we operationalized aspects of the Brown and Edelson continuum to characterize how IA projects integrate OER (see Table 2). To measure inter-rater reliability, one coder scored all 72 IA projects and a second coder scored a random subset of IA projects. Krippendorff's alpha suggests moderate to high reliability ( $Kalpha = .69$ ).

Table 2

*Rubric for Measuring OER Integration (OAI Scale) (Recker et al., 2007)*

Score	Name	Definition
1	Offload	Teachers provide links to OER with little additional teacher-created instructional guidance (e.g., no explanations or instructions). Use tends toward lists of links (perhaps with added navigational information). For example, see Figure 2.
2	Adaptation	A midpoint, with only some of the elements listed below.
3	Improvisation	Teachers link to OER as a starting point or reference but have clearly designed their own instructional elements, for example by including learning goals, instructional activities, descriptions of OER use, or assessment items. For an example, see Figure 1.

## Research Design and Methods

The core research questions guiding this work follow the framework of Malone et al. (2009) and are thus organized around users (teachers) and artifacts (IA projects):

1. How do teachers engage in collective intelligence activities within the IA?
2. How do teachers' collective intelligence activities and their collective intelligence artifacts relate to a) the creation of inquiry-based IA projects, and b) the integration of OER within IA projects?

### Participants and Sampling Procedures

To investigate these two questions, we analyzed two different datasets corresponding to each of the questions. These datasets illustrate IA usage in two different settings. The first sample, “in the wild”, includes users who were not actively recruited to use the IA. The second sample, PD participants, was drawn from a teacher professional development (PD) opportunity centered around use of the IA conducted in a western U.S. state.

The sampling process for “in the wild” teachers was we selected users who created an IA account during the 2009 calendar year and also indicated their years of teaching experience in the optional portion of their profile when they registered with the IA. These 200 teachers created a total of 520 IA projects.

The second sample, PD participants, was comprised of 36 middle school mathematics and science teachers who participated in a professional development series lasting three months. The professional development (PD), described elsewhere (Walker et al., 2012), focused on enhancing teachers' technology skills for finding and selecting OER, and designing classroom activities around these OER using the Instructional Architect. These teachers created a total of 351 IA projects from September 2010 to August 2011. Using teacher journals, we selected two projects from each teacher (72 total) for further analysis using the following criteria: 1) the IA projects were created during the PD training period, 2) they were implemented in their classroom teaching, and 3) they were scored using the PBL alignment and OAI rubrics. As these teachers were all part of a sustained PD experience and those 72 projects were implemented in teaching, teacher behaviors and their IA project features are likely different from those of teachers “in the wild.”

### Data Sources

For these two samples of users, several sources of data were analyzed. First, users completed an optional user profile upon creating their free IA account, in which they were asked to rate their comfort level with technology on a Likert scale, and report their years of teaching experience. Second, the IA was instrumented to automatically collect and aggregate detailed usage data, as well as, third, IA project features (Khoo et al.,

2008). In addition, two IA projects created by each of the 36 PD participants (72 total IA projects) were hand scored in terms of their PBL alignment score and their OAI score (described above).

## Data Analysis

To address RQ1, we used descriptive statistics to explore IA usage from both teacher and IA project perspectives. Table 3 shows definitions for the variables examined in the study.

To address RQ2, correlation analyses were conducted to examine the bivariate relationship between the IA project variables (PBL or OAI score) and IA usage variables. Since the PBL alignment scores were not normally distributed and the OAI score was a categorical variable, Spearman ranked correlations were used. To further investigate what variable(s) predict the OAI scores, multinomial logistic regression models were fit. Before running the regression model, multicollinearity was examined according to the bivariate correlation analysis results, and no high correlations ( $> .8$ ) were identified. A series of models and predictor variables were tested using the backward elimination. The final models were selected based on their overall significance and parsimony.

Table 3

### *Definition of IA Usage Variables*

	IA usage variable	Definition
Teacher activities	# of logins	# of times a teacher logs into the IA system
	# of OER used in all IA projects	# of Open Educational Resources used in all IA projects
	# of IA projects created	# of IA projects created
	# of public IA projects created	# of public IA projects created
	# of IA projects copied from others	# of IA projects an IA user completely copied from other IA projects
	# of IA projects viewed	# of IA projects an IA user viewed except the ones created by himself or herself
IA projects features	# of words	# of words in the IA project content area, excluding the words in the overview area and the links
	# of links	# of links used in an IA project
	# of edits	# of times the IA project is edited by its author
	# of times viewed *	# of times a project has been viewed by all other users
	# of times copied*	# of times a project has been copied by all other users

*Note.* \*Only teacher-averaged IA project features are available in the dataset for “in the wild” users, therefore “# of times viewed” or “# of times copied” are not reported.

## Results

### Research Question 1: Teacher Collective Intelligence Activities

The first research question explored organic teacher activity and how it might relate to teachers' collective intelligence processes. Table 4 shows summary data for the 200 "in the wild" teachers who created an IA account over the course of one year, and the 520 IA projects they created. On average, these teachers created a small number of IA projects and chose to share almost two thirds of them. In addition, 15% of their IA projects were copied directly from other IA projects. Thus, these teachers can be seen as both contributors to and consumers of crowdteaching.

Further, the distribution of most usage values is skewed and follows a Zipf (or long tail) distribution (Anderson, 2006; Recker & Pitkow, 1996). As is common in many Internet-based datasets, a small number of users account for a majority of the activity (see Figure 3 for an example of a histogram of teachers' number of logins). This has also been called the "90-9-1" rule or "participation inequality," in that in typical online communities, 90% of participants are lurkers, 9% contribute occasionally, and 1% account for the most contributions (Nielsen, 2006).

Table 4

*Descriptives of Users' (N = 200) Activity and Their IA Project Features (Data Collected over a 1-Year Period)*

	Variable	Mean	Median	SD	Min	Max
Teacher activities (N = 200)	# of logins	10.38	7	10.59	1	57
	# of OER used in all IA projects	16.82	10	24.02	0	217
	# of IA projects created	2.60	2	2.04	1	10
	# of public IA projects created	1.73	1	1.95	0	10
	# of IA projects copied from others	.58	0	1.46	0	9
	% of IA projects copied from others	15.22	0	29.50	0	100
IA projects features (N = 520)	# of IA projects viewed	12.98	7	17.44	0	134
	# of words	186.02	94	308.02	0	2692
	# of links	4.23	3	4.17	5	28
	# of edits	2.87	2	3.29	0	21

*Note.* '0 OER used in all IA projects' denotes teachers who did not use any OER in their IA projects; '0 words' denotes IA projects with only link(s) and without any words in the project content area; '0 links' denotes IA projects with no links; '0 edits' denotes IA projects without modification after creation.



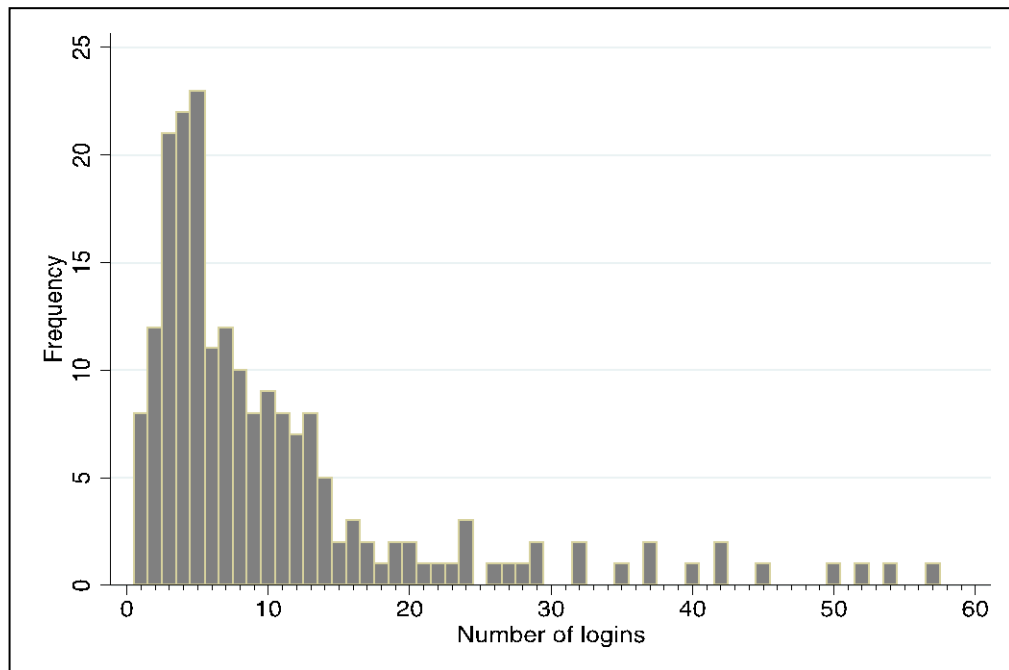

Figure 3. Histogram of teachers' number of logins over a 1-year period.

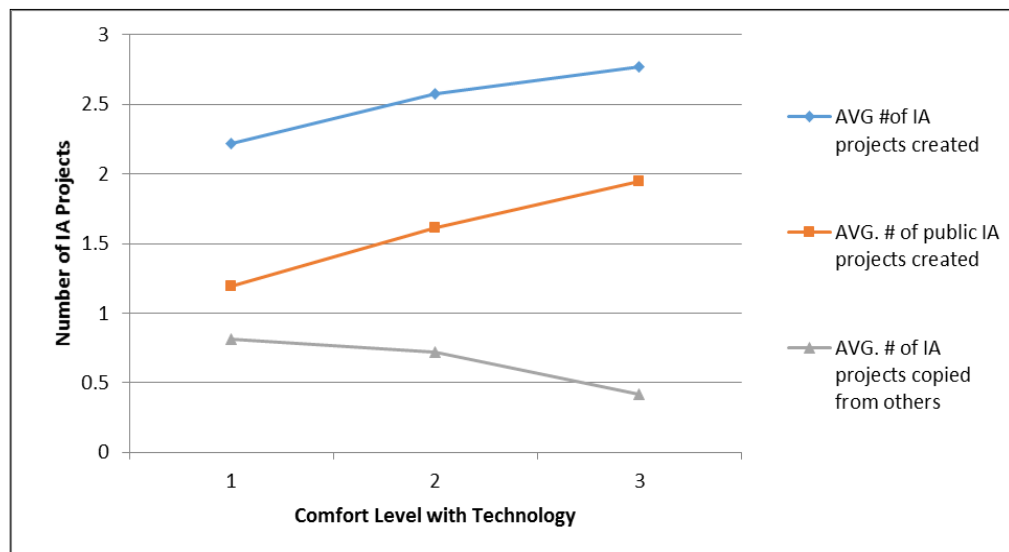

Figure 4. Teachers' creation activity categorized by their comfort level with technology. (For PD participants, comfort level with technology ranges from "0" to "4" levels; "0" refers to "novice" and "4" refers to "expert". However, due to a change in the interface "in the wild" users reported their comfort levels on "1" to "3" scale.)



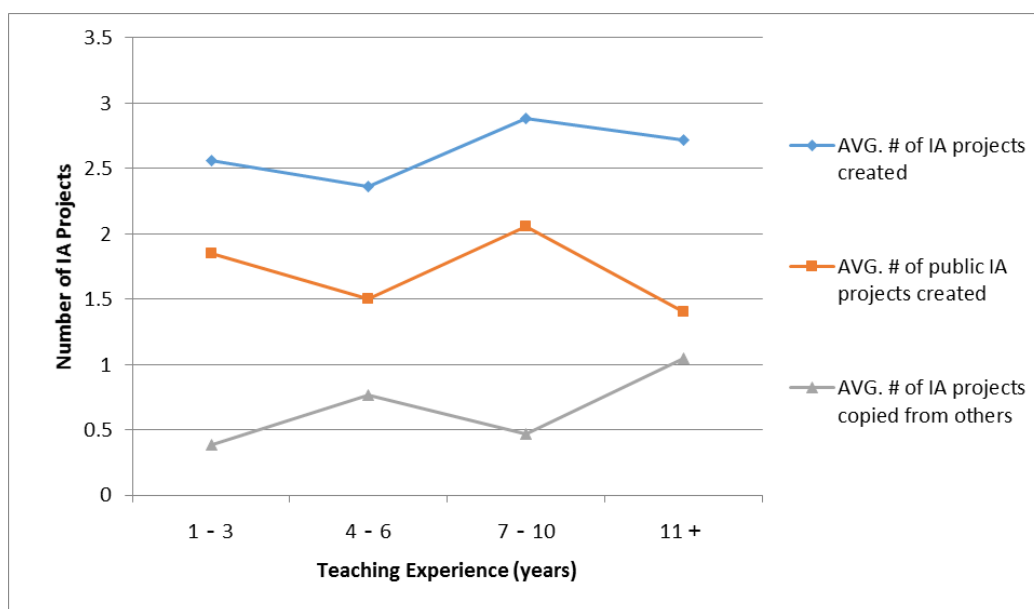

Figure 5. Teachers' creation activity categorized by their teaching experience.

Figures 4 and 5 show these teachers' IA project creation activity categorized by their self-reported comfort levels with technology and their years of teaching experience. Figure 4 shows that teachers who had a higher comfort level with technology appeared to have more contributor behavior: They created and shared the most IA projects but copied less. Teachers who had a lower comfort level with technology tended to display more consumer behavior: They created and shared less IA projects but copied more. Figure 5 shows teachers' usage activity categorized by their self-reported teaching experience. Here, no clear pattern was apparent.

In sum, teachers can be involved in crowdteaching in different ways: offering wisdom by making their IA projects public, and benefiting from others' wisdom by viewing and copying IA projects. In terms of enhancing the collective intelligence of the community, the challenge then becomes automatically deriving metrics that help identify IA projects that are valued in the community. This challenge is addressed next.

### Research Question 2a: Problem-Based Learning Alignment

This research question examines the relationship between IA project features, teacher characteristics, and the creation of inquiry-oriented IA projects. Table 5 shows summary data for the 36 teachers and their 72 IA projects for data collected over one year.

In comparison to those IA projects created by teachers "in the wild," these IA projects showed a much higher average number of edits, suggesting higher levels of effort. In addition, perhaps because these teachers were part of a sustained PD intervention, these teachers also showed, on average, higher levels of IA activity, including number of logins, IA project created, projects viewed, projects copied, and OER collected.

Table 5

*Descriptives of PD Participants' (N = 36) Activity and IA Project Features (N = 72) (Data Collected over a 1-Year Period)*

	Variable	Mean	Median	SD	Min	Max
Teacher activities (N=36)	# of logins	31.42	27	28.02	6	179
	# of OER used in all IA projects	33.72	23	31.39	8	179
	# of IA projects created*	9.50	7	9.07	2	57
	# of public IA projects created	4.08	3	7.98	0	49
	# of IA projects copied from others	2.25	1	2.78	0	12
	% of IA projects copied from others	25.49	18.33	25.78	0	80
	# of IA projects viewed	20.39	21	11.86	2	52
IA project features (N=72)	PBL Alignment Score	3.32	2	3.45	1	17
	# of words	169.86	113.50	168.28	9	859
	# of links	5.36	4	4.50	0	37
	# of edits	69.94	51	63.70	5	388
	# of times viewed (N = 51)**	336.84	199	391.96	13	1995
	# of times copied (N = 51)**	0.47	0	.95	0	4

*Note.* \* A total of 351 IA projects were created and 72 were selected for detailed analysis.

\*\* Only public IA projects can be viewed and copied.

Of these 72 IA projects, 51 (70.83%) were made public by their authors, meaning they could be viewed and copied by others. Table 5 shows that the 51 public IA projects were viewed more frequently than they were copied, suggesting that the IA users preferred to view IA projects for ideas and OER rather than to completely copy them. Copying an IA project may be an indication that a teacher places a very high value upon it. Table 5 also shows that overall mean scores for PBL alignment were low and their distribution was skewed ( $M = 3.32$  on a 22-point scale). This skew precluded the use of statistics assuming normality, such as Pearson's correlation and multiple regression.

Spearman's rank order correlation coefficients were calculated to investigate the relationships between various IA project features and PBL alignment scores (see Table 6). Results suggest that PBL alignment scores are positively and moderately correlated with the number of words and the number of views. Thus, if the PBL alignment score is viewed as an indicator of a useful IA project, the number of views and words can act as an indirect proxy of this measure. Table 6 also shows positive and moderate correlations between the number of words and the number of links, edits, and views. Moderate positive correlations were also found between the number of times an IA project was edited and the number of links and views.

Spearman's rank correlations were used to explore the relationships between teacher characteristics and the PBL alignment score of their IA projects. Table 7 shows that teachers' reported teaching experience was moderately and negatively correlated with a

variety of IA activities, such as the number of logins, the number of OER used, the number of IA projects created, the number of public IA projects created, and the number of the IA projects viewed, suggesting that novice teachers may have found certain features of the IA more useful. Additionally, Table 7 shows a positive correlation between teachers' comfort level with technology and the number of public IA projects created. Thus, as teachers' comfort level with technology increases, they tend to publish and share more IA projects. This is similar to the pattern identified in Figure 4.

Other moderate and positive correlation results are not surprising and suggest that an engaged user shows overall higher levels of activity on all IA features. Note, however, that no strong correlations were found between the PBL alignment score and teacher characteristics.

Table 6

*Spearman's Rank Correlations between PBL Alignment Score, OAI Score, and IA Project Features for IA Projects Created by PD Participants*

Variable	1	2	3	4	5	6
1. PBL alignment score						
2. IA project OAI score	.30*					
3. #of words	.42**	.60**				
4. # of links	.08	.23	.27*			
5. # of edits	.19	.43**	.52**	.38**		
6. # of times viewed (N=51)	.38**	.25	.28*	.26	.37**	
7. # of times copied (N=51)	.09	.36*	.001	-.05	-.08	.19

\*  $p < .05$ ; \*\*  $p < .01$ .

Table 7

*Spearman's Rank Correlations between PBL Alignment Score, OAI Score, and Characteristics of PD Participants*

Variable	1	2	3	4	5	6	7	8	9
1. PBL alignment score									
2. IA project OAI score	.30*								
3. Teaching experience	-.22	-.14							
4. Comfort level with technology	.10	-.07	-.08						
5. # of logins	-.05	.24*	-.32**	-.23					
6. # of OER used in all IA projects	.15	.27*	-.41**	-.14	.30**				
7. # of IA projects created	-.06	-.003	-.33**	-.02	.58**	.60**			
8. # of public IA projects	-.08	.07	-.35*	.30**	-.02	.30**	.18		
9. # of times user copied IA project	.20	.18	-.07	.07	-.03	.51**	.37**	.09	
10. # of IA projects viewed	-.09	-.07	-.34**	.13	.40**	.39**	.52**	.15	.17

\*  $p < .05$ ; \*\*  $p < .01$ .

## Research Question 2b: Use of OER in IA Projects

This question examines the relationship between IA project features, teacher characteristics, and how IA projects are designed to integrate OER. For these 72 IA projects, 23 (31.9%) of the IA projects were categorized as an offload, 38 (52.8%) IA projects were in the adaptation category, and 11 (15.2%) IA projects were in the improvisation category (see Table 2 for definitions).

Spearman's rank order correlation coefficients were calculated between OAI scores and IA project features (see Table 6). Results show that OAI score is positively correlated with the number of words, the number of edits, and the number of times an IA project was copied. Thus, as the number of words, edits, and copies of an IA project increased, its OAI score increased toward the improvisation end of the scale.

Spearman's rank order correlation was also used to investigate the relationships between OAI scores and teachers' characteristics (see Table 7). Results suggest that OAI scores are significantly and positively correlated with teachers' number of logins and number of OER used. Thus, as a teacher's number of logins and number of OER used

increased, the OAI score of their IA projects increased toward the improvisation end of the scale.

As noted, Tables 6 and 7 show that the OAI scores of the 72 IA projects are significantly and positively correlated with the number of words, the number of edits, the number of times an IA project was copied, the number of logins, and the number of OER used. Several of multinomial logistic regression models were fit to test whether different combinations of these five variables could significantly predict the OAI scores of IA projects. Note that multicollinearity was examined and eliminated as a concern for this dataset. Two final models are reported as follows.

The first multinomial logistic regression model (see Table 8) was based on the 72 IA projects with four predictor candidates. The results show that only the number of words is a significant predictor of OAI score. This means that after holding other variables constant, for each unit increase in the number of words, the multinomial odds ratio for an IA project in the adaptation category (OAI = 2) relative to the offload category (OAI = 1) would be expected to increase by 2%. Similarly, after holding other variables constant, for each unit increase in the number of words, the multinomial odds ratio for an IA project in the improvisation category (OAI = 3) relative to the offload category (OAI = 1) would also be expected to increase by 2%.

Table 8

*Multinomial Logistic Regression on OAI Score for 72 IA Projects*

Variable	Adaptations (OAI = 2)			Improvisation (OAI = 3)		
	OR	Wald $\chi^2$	<i>P</i>	OR	Wald $\chi^2$	<i>P</i>
# of words	1.02	7.21	.007 **	1.02	8.54	.003**
# of edits	1.01	1.56	.21	1.02	3.10	.08
# of logins	1.02	.49	.49	1.02	.37	.54
# of OER used in all IA projects	1.01	.09	.76	1.00	.003	.96

*Note.* The reference category is offloads (OAI = 1). \*\*  $p < .01$ .

Table 9

*Multinomial Logistic Regression on OAI Score for 51 Public IA Projects*

Variable	Adaptations (OAI = 2)			Improvisation (OAI = 3)		
	OR	Wald $\chi^2$	<i>p</i>	OR	Wald $\chi^2$	<i>p</i>
# of times copied	1.07	.02	.89	2.69	4.00	.046*

*Note.* The reference category is offloads (OAI = 1). \*  $p < .05$

The second multinomial logistic regression (see Table 9) was based on the 51 public IA projects and one predictor was retained in the final model. The results indicate that the number of times users copied IA projects is a significant predictor of OAI score. For each unit increase in the number of times users copied an IA project, the multinomial odds ratio for a project in the improvisation category (OAI = 3) relative to the offload category (OAI = 1) would be expected to increase by 169%. However, the comparison between the adaptation category (OAI = 2) and the offload category (OAI = 1) did not show this trend.

In sum, among the five variables that are significantly correlated with the OAI scores of the IA projects, only the number of words and the number of times an IA project was copied were significant predictors of OAI score.

## Discussion

The evidence suggests that collective intelligence (called crowdteaching) activities occur within the IA. Teachers, on average, chose to share almost two thirds of their created artifacts, while a small proportion of their IA projects were copied directly from other IA projects. Thus, these teachers can be seen as both contributors to and consumers of crowdteaching processes. In addition, IA users preferred to view IA projects rather than to completely copy them. This suggests that they may be browsing for ideas or finding only a smaller set of IA projects that completely meet their needs. Copying an IA project suggests a higher level of endorsement of its content. Finally, PD participants showed overall greater levels of IA activity, compared to those teachers “in the wild.” Thus, like findings from other research of loose online communities (Abramovich & Schunn, 2012; Nielsen, 2006), participation shows deep inequalities, but can be nurtured.

In examining the possible influences of teacher characteristics, we noted similar patterns in the two samples of teachers in terms of their reported comfort level with technology. “In the wild” teachers with lower levels of comfort in technology use appeared to display more consumer behaviors, while higher level teachers appeared to show more contributor behaviors. A similar pattern is also evident in the PD participants: Teachers’ comfort level with technology was positively (and moderately) correlated with sharing behaviors. In terms of the teaching experience, patterns were different. “In the wild” teachers showed no clear pattern; for PD participants, teaching experience was negatively (and moderately) correlated with IA project creation and sharing. We also acknowledge that as self-reported data, these may not capture the most important underlying constructs.

In addition, a goal was to find proxy variables that could be easily computed and that also aligned to instructionally relevant indicators. Distilling such variables could support IA users (teachers) in quickly identifying useful IA projects to either use or further adapt. We coded IA projects implemented in classrooms by teachers using two

indicators, the problem-based learning rubric and the OAI scale, and examined their relationship with several usage metrics. Correlational results suggest that among several metrics related to two instructional indicators, the number of words in IA projects was the best indirect proxy of both indicators.

It is possible that IA projects with more content (i.e., words) would necessarily score higher on these two indicators. However, it is unclear that simply having more textual content would cause raters to find greater evidence of inquiry learning elements, or improvisation around OER. Similarly, a comprehensive study of Wikipedia article quality also found that the number of words was the most robust (and easiest to extract) predictor of quality although there is no reason to expect that lengthy encyclopedia articles are necessarily better (Blumenstock, 2008).

We note that this study had several limitations. The first is the small number of users and IA projects analyzed against the larger backdrop of users and usage. True crowdsourcing environments typically assume an Internet-scale community behind crowdsourcing activities (Estellés-Arolas & González-Ladrón-de-Guevara, 2012). In our case, we restricted our analyses in the first sample to users who clearly identified themselves as teachers, which severely restricted the user base. Because we relied on these users voluntarily completing a brief demographic survey, we may have unintentionally excluded actual teachers. In the second sample, however, we deliberately only included IA projects that teachers told us were used in actual classroom practice. In the future, instead of using a restricted sample, a more systematic sampling process should be employed and more comprehensive teacher demographic information should be collected. Finally, we relied upon two indicators of instructional quality. It is certainly possible that others could be identified that could serve as more robust indicators.

## Conclusion

This article explored collective intelligence processes in the context of a Web-based tool for teachers, the Instructional Architect, to support teachers as designers using OER. Our analyses were guided by a framework, which posits a very loose notion of community wherein members may have very diffuse interactions with one another (Malone et al., 2009). The IA community is in that vein.

Results of the study have implications for both research and practice in the OER community. From the research perspective, this study reveals different patterns in terms of how teachers engage with OER: They can be contributors by creating and sharing new content; or they can be consumers by viewing and even copying other teachers' content. In addition, the study identified various factors that influenced teachers' engagement with the IA, such as their teaching experiences, comfort levels with technology, and whether or not they attended professional development

workshops. Moreover, the analysis of user activities indicates that the frequency of teacher activities in the IA often followed the “long tail” distribution, which provides further evidence for Nielsen’s (2006) participation inequality rule.

In terms of practice, results from the study have implications for system design. For example, the “decide-how” dimension is largely done individually, and supports for this step within the IA are mostly implicit. As such, scaffolds in the IA interface could be designed to better represent user activity (e.g., sorting search results by identified proxies of quality, including number of words, views, or copies) in order to help teachers better leverage crowd wisdom.

Future work includes developing means for automatically conducting longerterm analyses of the activities of IA users, as well as the evolution of their artifacts. We are also developing computational approaches that can scale to study how the micro-level activities of these users and their designs might affect the macro-level behaviors of the community as a whole (Walker et al., 2011).

## Acknowledgements

The authors would like to thank the study participants for their time and assistance. This material is based upon work supported by the U.S. National Science Foundation under Grant No. 0937630, and Utah State University. Any opinions, findings, and conclusions or recommendations expressed in this material are those of the author(s) and do not necessarily reflect the views of the National Science Foundation. Portions of this research were previously presented at the American Educational Research Association Annual Meeting (AERA 2013) in San Francisco.



## References

- Abramovich, S., & Schunn, C. (2012). Studying teacher selection of resources in an ultra-large scale interactive system: Does metadata guide the way? *Computers & Education*, *58*(1), 551–559.
- Anderson, C. (2006). *The long tail: Why the future of business is selling less of more*. New York, NY: Hyperion.
- Atkins, D. E., Brown, J. S., & Hammond, A. L. (2007). *A review of the open educational resources (OER) movement: Achievements, challenges, and new opportunities*. Retrieved from <http://www.hewlett.org/Programs/Education/OER/OpenContent/Hewlett+OER+Report.htm>
- Ball, D. L., & Cohen, D. K. (1996). Reform by the book: What is—or might be—the role of curricular materials in teacher learning and instructional reform? *Educational Researcher*, *25*(9), 6–14.
- Barrows, H. S. (1996). Problem-based learning in medicine and beyond: A brief overview. *New Directions for Teaching and Learning*, *68*, 3–16.
- Benkler, Y. (2006). *The wealth of networks: How social production transforms markets and freedom*. New Haven, CT: Yale University Press.
- Blumenstock, J. (2008). Size matters: Word count as a measure of quality on Wikipedia. *Proceedings of the 17th International Conference on World Wide Web (WWW '08)* (pp. 1095–1096). ACM, New York, NY, USA. doi:10.1145/1367497.1367673. Retrieved from <http://doi.acm.org/10.1145/1367497.1367673>
- Borgman, C., Abelson, H., Dirks, L., Johnson, R., Koedinger, K., Linn, M., ... Szalay, A. (2008). *Fostering learning in the networked world: The cyberlearning opportunity and challenge, a 21st century agenda for the National Science Foundation* (Report of the NSF Task Force on Cyberlearning). Retrieved from the National Science Foundation website: <http://www.nsf.gov/pubs/2008/nsf08204/nsf08204.pdf>
- Brown, M., & Edelson, D. (2003). *Teaching as design: Can we better understand the ways in which teachers use materials so we can better design materials to support their change in practice?* (Design Brief). Evanston, IL: Center for Learning Technologies in Urban Schools.
- Custard, M., & Sumner, T. (2005). Using machine learning to support quality judgments. *D-Lib Magazine*, *11*(11).

- Davis, E. A., & Krajcik, J. S. (2005). Designing educative curriculum materials to promote teacher learning. *Educational Researcher*, 34(3), 3–14.
- Davis, E. A., & Varma, K. (2008). Supporting teachers in productive adaptation. In Y. Kali, M. C. Linn, M. Koppal, & J. E. Roseman (Eds.), *Designing coherent science education: Implications for curriculum, instruction, and policy* (pp. 94–122). New York, NY: Teachers College Press.
- Drake, C., & Sherin, M. G. (2006). Practicing change: Curriculum adaptation and teacher narrative in the context of mathematics education reform. *Curriculum Inquiry*, 36(2), 153–187.
- Estellés-Arolas, E., & González-Ladrón-de-Guevara, F. (2012). Towards an integrated crowdsourcing definition. *Journal of Information Science*, 38(2), 189–200.
- Farooq, U., Schank, P., Harris, A., Fusco, J. & Schlager, M. (2007). Sustaining a community computing infrastructure for online teacher professional development: A case study of designing Tapped In. *Journal of Computer Supported Cooperative Work*, 16(4-5), 397-429. Norwell, MA: Kluwer Academic Publishers.
- Fogleman, J., McNeil, K., & Krajcik, J. (2011). Examining the effect of teachers' adaptations of a middle school science inquiry-oriented curriculum unit on student learning. *Journal of Research in Science Teaching*, 48(2), 149–169.
- Kastens, K., Devaul, H., Ginger, K., Mogk, D., DeFelice, B., DiLeonardo, C., ... Tahirkheli, S. (2005). Questions & challenges arising in building the collection of a digital library for education: Lessons from five years of DLESE [computer file]. *D-Lib Magazine*, 11(11). Doi: 10.1045/november2005-kastens
- Khoo, M., Pagano, J., Washington, A. L., Recker, M., Palmer, B., & Donahue, R. A. (2008). Using web metrics to analyze digital libraries. In *Proceedings of the 8th ACM/IEEE-CS joint conference on digital libraries* (pp. 375-384). ACM.
- Leary, H., Giersch, S., Walker, A., & Recker, M. (2009). Developing a review rubric for learning resources in digital libraries. In *Proceedings of the 9th ACM/IEEE-CS joint conference on digital libraries* (pp. 421-422). ACM.
- Malone, T., Laubacher, R., & Dellarocas, C. (2009). Harnessing crowds: Mapping the genome of collective intelligence. *MIT Sloan Research Paper*, No. 4732-09.
- Mardis, M., ElBasri, T., Norton, S., & Newsum, J. (2012). The digital lives of U.S. teachers: A research synthesis and trends to watch. *School Libraries Worldwide*, 18(1), 70–86.
- Nielsen, J. (2006). Participation inequality: Lurkers vs. contributors in Internet

communities. Retrieved from <http://www.nngroup.com/articles/participation-inequality/>

- Penuel, W. R., & Gallagher, L. P. (2009). Preparing teachers to design instruction for deep understanding in middle school Earth science. *The Journal of the Learning Sciences, 18*(4), 461-508.
- Porcello, D., & Hsi, S. (2013). Crowdsourcing and curating online education resources. *Science, 341*(6143), 240-241.
- Recker, M. (2006). Perspectives on teachers as digital library users: Consumers, contributors, and designers. *D-Lib Magazine, 12*(9).
- Recker, M., Dorward, J., Dawson, D., Halioris, S., Liu, Y., Mao, X., ... & Park, J. (2005). You can lead a horse to water: Teacher development and use of digital library resources. In *Proceedings of the Joint Conference on Digital Libraries* (pp. 1–7). New York, NY: ACM.
- Recker, M., & Pitkow, J. E. (1996). Predicting document access in large multimedia repositories. *ACM Transactions on Computer-Human Interaction (TOCHI), 3*(4), 352-375.
- Recker, M., Walker, A., Giersch, S., Mao, X., Halioris, S., Palmer, B., ... & Robertshaw, M. B. (2007). A study of teachers' use of online learning resources to design classroom activities. *New Review of Hypermedia and Multimedia, 13*(2), 117-134.
- Remillard, J. (2005). Examining key concepts in research on teachers' use of mathematics curricula. *Review of Educational Research, 75*(2), 211–246.
- Sumner, T., Khoo, M., Recker, M., & Marlino, M. (2003). Understanding educator perceptions of "Quality" in digital libraries. In *Proceedings of the Joint Conference on Digital Libraries* (pp. 269–279). New York, NY: ACM.
- Walker, A., Recker, M., Ye, L., Robertshaw, M. B., Sellers, L., & Leary, H. (2012). Comparing technology-related teacher professional development designs: A multilevel study of teacher and student impacts. *Educational Technology Research and Development, 60*(3), 421-444.
- Wetzler, P., Bethard, S., Leary, H., Butcher, K., Zhao, D., Martin, J. S., & Sumner, T. (2013). Characterizing and predicting the multi-faceted nature of quality in educational web resources. *Transactions on Interactive Intelligent Systems, 3*(3).

Athabasca University 



## Analyzing the Effect of Learning Styles and Study Habits of Distance Learners on Learning Performances: A Case of an Introductory Programming Course



Ünal Çakıroğlu  
Karadeniz Technical University, TURKEY

### Abstract

This study examined the relationships among learning styles, study habits, and learning performances in an online programming language course. Sixty-two sophomore students who enrolled in an online introductory programming course participated in the study. Kolb's Learning Style Inventory (LSI) was used to measure the students' learning styles. Another inventory developed by the researcher was used to determine learners' study habits. An achievement test was used to put forward their learning performances. As a result, significant relationships between learning styles, study habits, and learning performances were revealed. The results present some ideas about distance learners' learning styles and study habits for instructors who wish to incorporate synchronous courses and support learners.

**Keywords:** Learning styles; study habits; learning performances; distance learning; synchronous settings

## Introduction

To respond to the diverse distance and time needs of today's learners, many institutions offer online courses to expand their teaching methods with distance learning courses. They work on specializing or adapting the courses according to learners' needs (Hamilton-Pennell, 2002). Learners' needs include different learning styles which can influence learning performance (Mitchell, 2000; Chen & Lin, 2002; Morris, Finnegan, & Sz-Shyan, 2005; Hummel, 2006).

Definitions of learning style generally focus on ways of learning. According to Fleming (2001) learning style is an individual's preferred way of gathering, organizing, and thinking about information. It is considered as the behaviors related to the psychological, cognitive, and affective domains of interaction with learning environments. Learning style involves learners' preferred ways to receive, process, and recall information during instruction which is related to learners' motivation and information-processing habits (Aragon, Johnson, & Shaik, 2002).

Research studies on learning styles have shown that learning can be enhanced through consideration of personal characteristics in design and delivery of the instruction (Dziuban, Moskal, & Hartman, 2004; Fearing & Riley, 2005). Because some learners tend to focus on facts, data, or procedures, engaging with theories and mathematical models is appropriate. Other learners use visual information like pictures, diagrams, and simulations to understand better, while others can get more from oral and written information. Researchers have argued that learning style also functions as a useful indicator for potential learning performance (Kolb & Kolb, 2005; Smith & Ragan, 1999; Sun et al., 2008). In this context, Dunn and Dunn (1978) stated that students with different learning styles have distinct preferences during different instructional activities. Thus, various models have been proposed by theoreticians and used by educators in order to measure learning styles, and various instruments have been used.

Coffield et al. (2012) provided an extensive report which involved at least 71 learning style models. The models have some components different from each other related to the extent that they may change over time for learners. Some popular instruments were various extensions of Jung's (1970) psychological types and Gardner's (1993) multiple intelligences. One of the widely used models in this area was developed by Gregorc and Butler (1984) which has four combinations of perceptual qualities and ordering abilities: concrete sequential, abstract random, abstract sequential, and concrete random. In this model it is considered that each individual can be strong in one or two of the four styles. As a contrast to Gregorc (1984), Felder and Silverman (1988) did not consider learning styles to be constant. According to them, learning preferences may change due to the time and situation. Fleming's (2001) VARK inventory, which includes visual, aural, read-write, and kinesthetic perceptual styles, and the specific inventory of Felder and Soloman (1997), which measures learning preferences across four bipolar preferences, active-reflective, sensing-intuitive, visual-verbal, and sequential-global, are well known examples derived from the models above.

One of the popular learning style inventories for determining adults' learning styles is Kolb's Learning Style Inventory (LSI). It includes four dimensions: concrete experience (feeling), reflective observation (watching), abstract conceptualization (thinking), and active experimentation (doing) (Kolb, 1985). Through four dimensions, Kolb determined four learning styles: accommodative, divergent, convergent, and assimilative.

Many research studies have been conducted using Kolb's inventory in order to determine learning styles. For example, Jonassen and Grabowski (1993) in their study suggested that the LSI was more suited to having students explore their learning styles than to predicting their ability to succeed. Terrell (2002) made a comparison of graduation rate by learning style of 216 students. He found most of the students were either convergers or assimilators and the comparison was not statistically significant. In addition, Fahy and Ally (2005) used Kolb's LSI for two online courses including asynchronous discussions. Akkoyunlu and Soylu (2008) revealed that students' views on the blended learning process, such as ease of use of the web environment, evaluation, face to face environment, and so on, differ according to their learning styles.

On the other hand, Honey and Mumford (1986) developed a self-development tool based on Kolb's model by inviting managers to address trainees' learning style preferences. They used the tool on a wide range of higher education students. In this instrument they identified four distinct learning styles: activists, theorists, pragmatists, and reflectors.

## Learning Styles in Distance Learning

Some researchers focused on the learning styles of distance learners. In this sense, Allen et al. (2002) suggested delivering courses in a variety of formats to accommodate multiple learning styles. Benbunan-Fich and Hiltz (2003) deemed it necessary to conduct research into the relationship among learning styles, the chosen mode of delivery, and student success. In another study Liegle and Janicki (2006) investigated the effect of learning styles on the Internet navigation needs of web based learners, finding that students as explorers provided a higher number of visits to linked web pages, whereas observers tended to be more passive. Also a few of the studies focused on academic performances and learning styles. Akdemir and Koszalkab (2008) determined the relationships between instructional strategies and learning styles in an online graduate level course. In the study, although using different kinds of instructional strategies for various learning styles learners' performances were equivalent. In another study, Popescu (2010) studied relationships between web-based educational systems and learning styles and found that accommodators benefited more than others in the learning process. Also, Shaw (2012) found that different learning styles were associated with significantly different learning scores. In addition, Schellens and Valcke (2000) and Neuhauser (2002) did not find such relationships between learning style and learning performance in online learning.

Furthmore, some studies were conducted in the distance learning area using Kolb's inventory. In one of those studies, Wang et al. (2006) focused on the effects of formative assessment and learning style on student performances in a web-based learning environment. The results showed that both learning style and formative assessment strategy were significant factors affecting student achievement in a web-based learning environment. Sun et al. (2008) used Kolb's inventory for investigating the learning outcomes related to different learning styles in a virtual science laboratory for elementary school students. Students who used the online virtual lab were not significantly different from students of different learning styles. Kolb's LSI was used in other online learning research studies to measure learners' preferences and learning styles (Dringus & Terrell, 2000; Federico, 2000; Fahy & Ally, 2005; Miller, 2005; Liegle & Janicki, 2006; Wang et al., 2006; Lu et al., 2007) .

## Study Habits

Study habits act as another variable connected with distance learners' performances. Study habits reflect students' usual act of studying and also call forth and serve to direct the learner's cognitive processes during learning. Study habits includes a variety of activities: time management, setting appropriate goals, choosing an appropriate study environment, using appropriate note-taking strategies, choosing main ideas, and organization (Proctor et al., 2006).

An increasing number of college courses are delivered online, especially with the use of synchronous technologies, which provides an opportunity for educators to search for the most suitable learning environments for students' study habits. According to the technology used, online settings can meet learners' needs. A wide variety of videos, images, animations, texts, audio, and so on can be shared and virtual presentation media can be created. In this sense, Sharpe and Benfield (2005) reviewed the experiences and study habits of e-learners in higher education in order to identify areas worthy of future investigation. They found some connections among habits and performances and suggested deeper investigation into eliciting the experiences, habits, and strategies of effective e-learners. So, recent developments in DL technologies have grabbed the attention of researchers regarding how pedagogical approaches are required to function within this framework.

Thus, there emerges a need to gain an insight into the requirements, expectations, study habits, and learning styles of learners before new environments are included in online courses in higher education.

## Purpose of the Study

In their study, Akdemir and Koszalka (2008) reported that effective design of instruction for online learning is most likely related to the characteristics and study preferences of the learner, as it is in a classroom. In this context, some studies mostly



focused on attitudes towards learning environments or engagement in the learning environments (Simpson & Yunfei, 2004; Popescu, 2010). Only a few studies focused on the preferences and performances of learners (Richmond & Liu, 2005). Thus, the purpose of this study was to explore the relationship between students' learning styles and study habits in accordance with their learning styles in an online distance learning environment. Sub-problems were related to the connection between Kolb's learning styles, study habits of distance learners, and their learning performances. This would provide an insight into the satisfactory features of a synchronous setting for various learning styles and study habits and the requirements of the setting for quality instruction.

The research questions were as follows:

- What is the relationship between learning styles, study habits, and learning performances in an online learning environment?
- Do learning styles and study habits effect differently learners who have different learning performances?

This paper also provides suggestions about how Kolb's learning styles may be used and how learners' study habits may be taken into consideration in online learning environments.

## Study Framework

In this study Kolb's learning cycle model was used as a framework for determining learning styles (shown in Figure 1). These four learning cycles are associated with learning styles. For instance, a converger favors the learning cycle of abstract conceptualization and active experimentation.

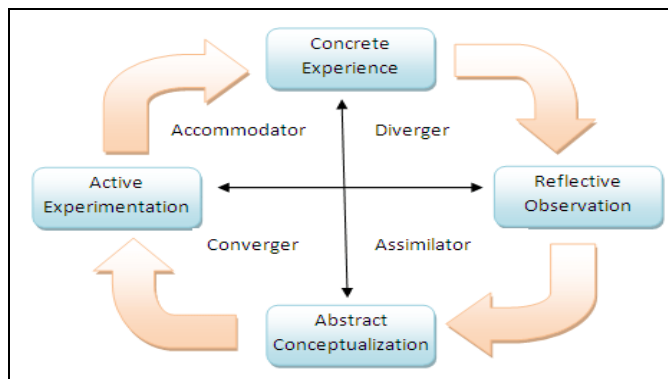

Figure 1. Kolb's learning cycle model (Kolb, 1985).

Healey and Jenkins (2000) and Manochehr (2006) worked on Kolb's learning cycle model and enhanced it with relationships among learning styles, learning conditions,

and conditions where learners can learn best. The learning styles and conditions are shown in Table 1.

Table 1

*Learning Styles and Conditions* (Manochehr, 2006)

Learning style	They learn best through	Condition
Diverger	Feeling and watching	Learn when allowed to observe and gather a wide range of information
Assimilator	Thinking and watching	Learn when presented with sound logical theories to consider
Converger	Thinking and doing	Learn when provided with practical applications of concepts and theories
Accommodator	Feeling and doing	Learn when allowed to gain “hands on” applications

The four learning styles are as follows:

- *Assimilators* have abstract conceptualization and reflective observation. They usually concentrate on the logical validity of theories, rather than focusing on their applicability.
- *Accommodators* choose to learn by doing and feeling. They learn best through concrete experimentation. They are intuitive and often study examples. They are more likely to be observers than activists.
- *Convergers* choose to make use of abstract conceptualization as well as active experimentation. Those who learn in this way are quite able to attain success in the practical application of ideas and theories, solving problems and making decisions.
- *Divergers* learn best through concrete experience and reflective observation. Their imaginative ability is strong. They tend to be people-oriented and react with emotions.

This study is based on Kolb’s learning cycle and study habits framework outlined in Figure 2.

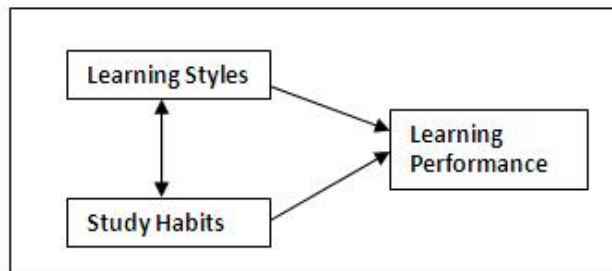

Figure 2. Study framework.

## Method

### Instruments

In order to meet the research questions, a Turkish version of Kolb's Learning Style Inventory (LSI-T), Study Habits Inventory (SHI), and Achievement Test (AT) were used in this study.

**LSI-T:** In this study LSI-T was administered before the intervention and after the final examination. The inventory is a 12 item questionnaire appropriate for teens and adults. Each item has four answers, which are ranked by the respondents in terms of best fit on a scale of 1 to 4 (4 = *best*). It was based on Kolb's learning styles: converging (abstract, active), diverging (concrete, reflective), assimilating (abstract, reflective), and accommodating (concrete, active). LSI was adapted into Turkish and validated by Aşkar and Akkoyunlu (1993) with the internal reliability high, Cronbach's alpha between .88 and .73. The LSI was administered to the participants in enough time by giving them the necessary explanations in advance. Responses were analyzed by organizing them into two bipolar concepts: concrete experience (CE) versus reflective observation (RO) and abstract conceptualization (AC) versus active experimentation (AE) (Aragon, Johnson, & Shaik, 2002). The given scores for CE, AC, RO, and AE were summed and then  $AE - RO$  and  $AC - CE$  were calculated to determine learners' ultimate learning styles. The scoring ranks of one dimension were dependent on how a participant was measured relative to scores from other dimensions.

**SHI:** Study habits of the learners were found with the opinions of students on a five-point Likert scale. James and Gardner (1995) addressed three important factors about selecting an instrument for determining learning styles: defining the intended use of the data to be collected, matching the instrument to the intended use, and selecting the most appropriate instrument. In the study habits dimension, frequently used inventories include Learning and Study Skills Inventory (Weinstein & Palmer, 2002) and Inventory of Learning Processes (Schmeck, Geisler-Brenstein, & Cercey, 1991). Though they have some common items, they deal with study habits from different

dimensions. Thus with the help of previous studies a new inventory was developed for this study.

While developing the SHI, the studies (Crede & Kuncel, 2008; Göğüş & Güneş, 2011) taken as a basis included theoretical considerations, or qualitative analyses of the ways used by students study habits inventories. Eighty-one learners were asked to identify their study habits, such as which way of studying helped their understanding and their activities during the study process. The participants were different ages and from different socio-cultures. In order to build up the SHI, statements were chosen from the most commonly used ones. Then the items were classified in Patel's (1976) study habits categorization: planning work, reading, note taking, subject planning, concentration, exam preparation, typical habits, and typical school environment habits.

**AT:** AT was used for assessing the students' learning performances. It was conducted as pretests and posttests with respect to the content of an introductory programming course. In order to evaluate the students' achievement scores, mid-term exam scores and the final projects were graded and calculated. The mid-term score refers to an exam on the computer that tests the students' practical programming capability. The final exam included eight questions regarding introductory programming, including basic data structures, memory iteration, conditional statements, loops, recursive functions, procedures, and functions and problem solving. The achievement scores were calculated using the sum of 20% of the project scores as well as the scores for the mid-term examinations (30%), and the grades for the final project (50%). In addition, the author who was also the instructor interpreted his observations during the process in terms of learning styles and study habits.

## Participants

Participants of the study included 66 sophomore students from a Turkish faculty of education, in a computer teacher training program. At the beginning of the study, LSI-T was used for categorizing learners' learning styles, shown in Table 2.

Table 2

### *Participant's Learning Style*

Gender	Total	Converger		Assimilator		Accommodator		Diverger	
		<i>n</i>	%	<i>n</i>	%	<i>n</i>	%	<i>n</i>	%
Female	24	9	37.5	6	25	5	20.8	4	16.6
Male	42	16	38	13	30.9	7	16.6	6	14.3
Total	66	25	37.8	19	28.7	12	18.1	10	15.2

## Process

The introductory programming language course was delivered online both in synchronous and asynchronous settings. The synchronous setting serves desktop sharing, video sharing, audio, verbal chat, presentation, whiteboard, online survey functions. Moreover, video records of the courses were saved in the system for participants to use asynchronously. The instructor presented the content during synchronous sessions, and discussed students' questions. Basic problems in the introductory programming course examples were discussed, and experts' sample programming codes were delivered to the students.

## Results

The results of this study are presented in two sections: results from LSI-T and results from SHI with the correlations between learning styles and study habits and learning performances.

### Learning Styles

The findings from descriptive statistics on average scores of the students with different learning styles are shown in Table 3.

Table 3

*Average Scores of Four Learning Style Groups*

Groups	<i>n</i>	<i>X</i>	<i>sd</i>
Convergers	25	45.32	24.77
Assimilators	19	48.1	22.86
Accommodators	12	67.25	18.78
Divergers	10	68.1	19.88

ANOVA was conducted to determine whether there were significant differences among the average scores of four groups (assimilators, convergers, accommodators, divergers). The results of ANOVA are provided in Table 4.

Table 4

*ANOVA Results between Average Scores of the Four Learning Style Groups*

	Sum of squares	df	Mean square	F	p
Between groups	6625.878	3	2208.626	4.337	.008
Within groups	31572.379	62	509.232		
Total	38198.258	65			

It is indicated with *p* value ( $< .05$ ) that there is a statistically significant difference among the average scores of these four groups. In order to determine the source of the significant differences, the Tukey test was conducted. Results of the Tukey test are shown in Table 5.

Table 5

*Tukey HSD Test Results among Four Learning Style Groups*

Groups	Groups	Mean difference	Std. error	p
Convergers	Assimilators	-2.78526	6.86811	.977
	Accommodators	-21.93000*	7.92498	.036
	Divergers	-22.78000*	8.44349	.043
Assimilators	Convergers	2.78526	6.86811	.977
	Accommodators	-19.14474	8.32092	.109
	Divergers	-19.99474	8.81617	.117
Accommodators	Convergers	21.93000*	7.92498	.036
	Assimilators	19.14474	8.32092	.109
	Divergers	-.85000	9.66226	1.000
Divergers	Convergers	22.78000*	8.44349	.043
	Assimilators	19.99474	8.81617	.117
	Accommodators	.85000	9.66226	1.000

The Tukey's HSD test has demonstrated that the accommodators had significantly higher average scores than those of the convergers. In addition, the divergers had significantly higher average scores than those of the convergers with a .05 level of significance. The other comparisons were not found significant. Another analysis was done according to the average scores. In this analysis the students were separated into three sub-groups according to the learning performances (poor: 0-45, average: 46-69, good: 70+), within all of the groups. The average scores of the groups based on their learning styles is shown in Table 6.

Table 6

*Average Scores of Four Learning Style Groups and their Sub-Groups*

Sub-groups	Converger			Assimilator			Accommodator			Diverger		
	<i>n</i>	%	<i>X</i>	<i>n</i>	%	<i>X</i>	<i>n</i>	%	<i>X</i>	<i>n</i>	%	<i>X</i>
Poor	9	45	15.1	7	35	21.4	2	10	37.5	2	10	37.5
Average	10	40	55.3	7	28	56.1	5	20	62.6	3	12	60.5
Good	6	28.5	74	5	23.8	74.2	5	23.8	83.8	5	23.8	80.8
Total	25	37.8	45.3	19	28.7	48.1	12	18.1	67.2	10	15.1	68.1

## Study Habits

A survey was provided in order to reveal study habits which ranged from *strongly agree* = 5 to *strongly disagree* = 1. Mean values (*X*) and the standard deviations (*SD*) of the items are provided in Table 7.

Table 7

*Study Habits Average Scores and Standard Deviations of Sub-Groups*

Study habits	Poor ( <i>n</i> = 20)		Average ( <i>n</i> = 25)		Good ( <i>n</i> = 21)	
	<i>X</i>	<i>SD</i>	<i>X</i>	<i>SD</i>	<i>X</i>	<i>SD</i>
Home environment and planning of work	20.6	3.31	23.64	4.32	24.85	4.05
Reading and note taking habit	34.65	2.39	39	3.94	42.52	2.94
Planning of subjects	17.4	2.60	20.52	2.02	21.33	2.3
Habits of concentration	12	1.94	13.08	0.91	15.33	2.3
Preparation for examination	15.7	2.71	17.12	1.74	18.14	1.35
General habits and attitudes	31	6.1	38.32	4.16	45.47	5.42
School environment	39.7	3.85	43.68	3.79	42.80	5.29
Overall study habits	170.2	8.78	196.6	9.53	210.38	7.89

Table 7 shows those “good” students’ habits of concentration, and their reading as well as note taking habits, and general habits and attitudes are considerably higher than those of others. The preparation for examination habits of the “poor” and “average” students were ranked with a higher average score, while the home environment and planning of work habits of the “average” students feature with a higher score. To determine whether the three groups (good, average, and poor) have significant correlations between the study habit items and average scores of the groups, the

correlations between the study habits and average scores are determined and provided in Table 8.

Table 8

*Correlations between Study Habit Scores and Average Scores of the Sub-Groups*

Sh#	Study habits	Average Scores			
		All students ( <i>r</i> )	Good students ( <i>r</i> )	Average students ( <i>r</i> )	Poor students ( <i>r</i> )
Sh1	Home environment and planning of work	.444*	.071	.181	.154
Sh2	Reading and note taking habit	.624*	.181	.099	.093
Sh3	Planning of subjects	.548*	.515*	.318*	.433*
Sh4	Habits of concentration	.487*	.402*	.117	-.523*
Sh5	Preparation for examination	.373	.253	.454*	.070
Sh6	General habits and attitudes	.714*	.295*	.162	.236
Sh7	School environment	.327*	.102	.083	.455*

\* Correlation is significant at the 0.05 level (2-tailed).

The Pearson correlation (*r*) was assessed in accordance with Cohen (1998), classifying the *r* values as -1 = *perfect negative*, 0.75-1.00 = *strong positive*, 0.5-0.75 = *moderate positive*, 0.25-0.5 = *weak positive*, -0.25-0.25 = *no linear association*, -0.5 - -0.25 = *weak negative*, -1 - -0.75 = *strong negative*, 1 = *perfect negative*. The Pearson correlation coefficient indicates a moderate positive correlation between Sh2, Sh3, Sh6, and All Students average scores. Hence, as Sh2, Sh3, Sh6 increases, average scores for all students will also increase. Sh1, Sh4, and Sh7 had a weak positive correlation among the average scores for all groups. For the “good” students, only Sh3 had moderate positive correlations with average scores of the good group. There were only two habits of the average group that have positive correlations with study habits, which are actually weak, with Sh3 and Sh5. The correlation coefficients between the poor students’ average scores, Sh3 and Sh7, were weakly positive. Overall habits were calculated by means of the total habit scores of each study habit category. The correlations between the overall habits and average scores are provided in Table 9.

Table 9

*Correlations between Overall Habits and Average Scores of Sub-Groups*

Study habits	All students ( <i>r</i> )	Good students ( <i>r</i> )	Average students ( <i>r</i> )	Poor students ( <i>r</i> )
Overall habits	.884*	.108	.796*	.544



Correlations between the average scores for all students and overall habits as well as overall habits between the average scores of the “average” students were found to be strongly positive. Overall habits and good students’ average scores as well as poor students’ average scores were not significantly correlated.

## Discussion

### Learning Styles of Distance Learners

It can be suggested that the leading learning style was the convergers, where students typically choose to learn through practical applications, including solving problems, trying to make correct decisions, and preferring to work with technical works or problems, rather than working with social relations. Convergers were followed by the assimilators, who concentrate on abstract concepts, make reflective observations, and assimilate them into an integrated explanation. The accommodators and the divergers were close in that they rarely choose to learn through conducting experiments, taking risks (accommodators), and producing new ideas, observing the situations from different perspectives, and bringing different ideas together (divergers). Although the number of the divergers was the lowest, this group achieved the highest score of average scores. This is similar to Karademir and Tezel (2010), who found that Turkish university students are generally accommodators, and divergers are fewer in number than others.

The divergers had higher average scores and learn better through feeling and watching. This may be because they watched the samples and they have a good command of the details of this observation. The results were similar to Daniel’s (1999) finding that divergers preferred reflective observation (watching), and achieved significantly higher scores. In fact, it has been stated with respect to the characteristics of divergers that they “learn when allowed to observe and gather a wide range of information” (Manochehr, 2006). They view concrete situations from many perspectives and adapt those by observation, rather than by action. In this sense, it can be concluded that, particularly in a synchronous setting, it contributes to the understanding of their problem solving styles that they see the programming examples, while the instructor is presenting them. In addition, students could also follow the records of lesson videos asynchronously which might have allowed them to bring forward their observation abilities.

The students adopting a “diverger” learning style were followed by the “assimilator”, “accommodator”, and “converger” learning styles, respectively. In contrast to this study, Lu, et al. (2007) found no significant effect between Kolb learning styles and learning outcomes and the study results showed that the mean of learning outcomes of convergers and assimilators was higher than that of divergers and accommodators. In this sense, Sun et al. (2008) have observed that the experimental group making use of

the online activities was not considerably different from the students with different learning styles. They found that the accommodators gained the most significant achievements. The results of this study are confirmed by some studies but also have differences from others.

In addition, in this study students usually studied with short size programming examples which were not difficult to follow. The instructor provided the major statements related to the subject before presenting the examples and students were allowed to make reviews on the concrete experiences. In this sense, the description of programming by means of illustration and exercise showed a positive correlation with the divergers' focusing on concrete experiences. Also, students' cooperative brainstorming on their assignments or projects shows that there is an emphasis on social interaction. Looking at their average scores, the divergers were followed by the accommodators. This group of students learns through "feeling" and "doing". They were good at adapting to changed circumstances and they solved the problems in the homework given by the instructor intuitively. They usually choose to learn through self-analyzing such as trial and error and discovery learning. Although Shaw (2012) in his study on learning programming in online forums as well as Wang, et al. (2011) have emphasized that when learning how to program, it is essential that the practices of the students verify an important conclusion that actual practice in the programming language learning is superior to just watching information. The enhanced features of the synchronous system used in this study might create a monitoring and follow-up environment far beyond the simple online forum and contribute to the learning performance of the students. On the other hand, the common feature of "feeling" in the groups of divergers and accommodators shown in Table 10 indicates that the feature of "feeling" can be of importance in synchronous settings. The assimilators and convergers have a common feature of "thinking". The convergers are those who choose to learn through practical applications of concepts, and most of the students in the class adopted this style. These students like decision making, problem solving, and the practical application of ideas. It is interesting that convergers had lower average scores in the programming course, which consists of problem solving, although these students adopted problem solving and learn this way. In addition, the assimilators, who learn through demonstration, have the lowest average scores; however, a significant number of students choose this learning style. These students incorporate a number of different observations and thoughts into an integrated whole. In fact, it is emphasized that programming can be understood during a lecture; however, writing programming codes required different features (Robins, Rountree, & Rountree, 2003). Although the concentration of the divergers and accommodators with higher average scores on the concrete structures is an important common feature, it is interesting that the assimilators and the convergers most commonly preferred among the distance learners focus on abstract structures. The divergers show reflective characteristics, while the accommodators with a close average to the divergers choose to be actively involved in learning. Similarly, the assimilators adopt a reflective learning style, while the convergers adopt an active learning style. In this sense, it is seen that the active

involvement in learning would not have a considerable effect on learning programming in an online synchronous setting. Although Dringus and Terrell (2000) and Lippert, Radhakrishna, Plank, and Mitchell (2001) in their studies based on Kolbs's LSI found that learning style had no effect on success in online learning, this study provides some evidence that styles may be important while benefiting from various online learning technologies or may be effected by teaching strategies.

In this study, students were separated as poor, average, and good based on the pretest results. Among the poor students, the average scores of the accommodators and divergers were equivalent (37.5), and these scores were higher than those of the convergers (15.1) and the assimilators (21.4). Among the average students, the accommodators have the highest average scores, while the number of the students in this group was the lowest. The ranging of average scores as accommodators, divergers, assimilators, and convergers among the average students was the same for the good students. Considering all three groups, it is seen that the accommodators and the divergers had higher average scores than those of the convergers and the assimilators. At this point, it is quite interesting that the number of students in the groups of the accommodators and the divergers were low within each of three poor, average, and good groups.

Especially in the studies conducted among Turkish university students, it can be seen that the numbers of the divergers and the accommodators have a small share among the participants involved in the studies (Akkoyunlu & Soylu, 2008). Similarly, this study addresses some new data which were the same for online learning. The correlations between the learning styles and the average scores were also an important result of this study. This relationship is summarized in Table 10.

Table 10

*Relationships between Average Scores and Four Learning Styles*

Average scores	Features of learning styles			
	Feeling	Watching	Thinking	Doing
High average scores	Diverger Accommodator	Diverger		Accommodator
Low average scores		Assimilator	Assimilator Converger	Converger

The “doing” learning style was associated with nearly the same performance as the “watching” learning style because the divergers (watching) have higher average scores, while the average scores of the students adopting another learning style (assimilator) with watching had a lower average score. Similarly, students adopting the

accommodator learning style featured with “doing” had higher average scores than other students adopting the “doing” feature.

As a result, in this study, it has been asserted that there is a significant relationship between the learning style and the average scores as learning performances. In this sense, Mitchell (2000) concluded that learning style may be an important indicator of how effectively different instructional strategies can be applied for different types of learners enrolled in online courses. So, the findings of this study can be considered as evidence that learning styles can be an indicator for success in online courses carried out through an online synchronous system as an enhanced version of a DL course.

## Study Habits of Distance Learners

Results showed that the average study habit scores (SHS) were all ranged as  $SHS_{\text{poor}} < SHS_{\text{average}} < SHS_{\text{good}}$ . This reflects good students had better SHS scores than those of the other groups. Only the “school environment” category was ranged as  $SHS_{\text{average}} > SHS_{\text{good}}$ . In the other categories the students with high scores in study habits had also high average scores. For “overall habits” consisting of the total of seven study habits, the “good” students had also the highest SHS, and they were followed by the overall SHS of the “average” students. Additionally, the SHS of the “good” and “average” students were higher than those of the “poor” students. The results of the sub-groups’ academic achievements confirms the idea of Göğüs and Güneş (2011) that academic performances increased when students used effective study habits in online learning settings. In this sense, Robinson (2000) also found that certain bad study habits resulted in poor learning performance.

It is interesting that the average scores and the planning of subjects scores of the “good” students have a moderate positive correlation, and that there was a moderate negative correlation between the average habits of concentration scores and average scores of the “poor” students. A weak or a moderate positive correlation between the planning of subject and the average scores of each of the three groups (poor, average, good) suggest that it is also important for the students to plan the subjects in a synchronous setting. As is generally known, a programming course has a typically inductive conceptual structure; it is important to study by planning the subjects in order to achieve higher learning performance. This situation was also the same in the online environment. There was a positive correlation between the habits of concentration of “good” students, and a negative correlation between the average scores of the “poor” students. It is particularly difficult to enable concentration in online synchronous settings because learners are carefully following the course as they do not know when the instructor will ask a question and where the instructor will indicate something. In addition, it is known that there are many factors at home or at work that may disturb the concentration of distance learners. The missing parts of the lessons can be watched asynchronously through video records. However the body language of the instructor during the lecture cannot be felt which is important for the students’ concentration during the lesson. It is interesting that none of the habits of preparation for the examination, reading and note

taking and home environment, is correlated with the average scores in all groups. Although note taking is a most usable feature for the programming course in a class environment, it is not mostly preferred in the synchronous lessons. Maybe students did not want to miss the presentation of the instructor by spending extra time to take notes. Time management is an important issue in DL and some researchers consider it as a major concern for online students (McEwen, 2001).

Some authors suggest following the examples given during the online courses, rather than the short-term exam studies, in the programming course (Robins, Rountree, & Rountree, 2003). In this study, even if there were different exam preparation habits, they did not affect the average scores. As students follow the course from different environments (home, work, dorm, etc.) in distance education, naturally there emerge different environments during the active course hours. Although students' study environment at home was different, and they had different family features, the impact of these features on the learning performances in this course was not significant.

It may be concluded that the impacts of two study habits, planning and concentration, were prominent. Planning is related to organization and concentration is related to feeling. Planning is generally about the nature of the course and concentration is about the nature of the online synchronous setting. Considering all study habits together, some considerations can be presented that the students with positive study habits have higher average scores, and some habits may have an impact on the learning performances in the online synchronous settings, not entirely but in this aspect. It can be thought that the features (visual, audio, texts, animations, etc.) provided by the online synchronous settings might affect the development of positive study habits. In addition, the methods of the instructor's presentation can be considered as a factor playing a role in the development of positive habits. Hence Ally and Fahy (2002) concluded that in the online learning environments e-teachers must provide adequate support strategies for students with different learning styles.

## Conclusions

The results of this study showed significant relationships between the students' learning styles, study habits, and performances in online learning, and have offered an insight into the mode of delivery. The design of effective courses for distance learners is most likely to be in connection with the characteristics and preferences of the learner, as it is in the classroom. It was seen that the learners usually show characteristics of assimilators in online synchronous settings. However, the results have shown that the "divergers and accommodators" styles were associated with higher learning scores in synchronous settings. Another common characteristic of the good students was "feeling" according to the results of this study. So I suggest this for programming language learning, with online synchronous settings, and the students' active involvement to have positive feelings and to improve their learning performances.

It was found that there is a significant correlation between the two study habits (concentration and planning of subjects). Considering that it is difficult to control concentration in online synchronous settings, it is deemed necessary for the instructors and the environment designers to take special measures in this respect. The planning of work is not an easy task for distance learners to perform. At this point, instructors can announce their syllabus which may provide support for these students at the beginning of the terms. Hence, learning performances can be enhanced with measures to easily bring forward study habits for distance learners. In this study, home environment and planning of work, reading, and note taking habits do not have a significant correlation with academic achievement in online synchronous settings. In particular, it is quite difficult to apply note taking habits due to the nature of the online synchronous setting. At this point, it may be proper for instructors to highlight the course records and to direct the students to watch these records.

Learning styles and study habits not only indicate how learners learn, but they can help an instructor support individual students, so that they might teach successfully (Tseng, Chu, Hwang, & Tsai, 2008). The results can help instructors get to know and use different tools for different learning styles and study habits to increase the performance of the students. As Mupingo, Nora, and Yaw (2006) state some of the online classes may have an unknown make-up so the characteristics of online students may be unclear which makes it difficult to develop effective online courses. An instructor should take into account all the related factors and include the necessary components in the program when designing a synchronous course to facilitate student learning, through examination of the learning styles of the distance learners, various learner performances, and involvement in online environments. Considering the idea of Wolfe et al. (2006) using videos, chat rooms, whiteboards, discussion boards, and providing assignments to suit learners' preferences may enhance learners' academic performances.

In addition, Dağ and Geçer (2009) with their review stated that improving academic achievements in online learning not only involves learning styles but also motivation of the learner, demographic factors, teaching strategies, and teaching methods. Moreover, Göğüş and Güneş (2011) pointed out that study skills, time management skills, and learning habits exhibited strong relations with academic performance in online learning. Thus, administrating workshops and sessions may help students to develop appropriate study habits for the nature of the teaching strategies and technologies used.

At the institutional level in particular, institutions that want to transfer some of their conventional courses onto the web may grasp the differences among students' learning styles in creating flexible instructional strategies that allow for synchronous settings. For future studies, it is recommended that some new correlations can be assessed between learning styles and study habits, regardless of whether the learning styles may be effective in controlling study habits in online learning environments.

In conclusion, this study showed that matching learning styles and study habits with teaching methods will serve academic performance. Some inventories should be administered at the beginning of the course so that course design and structure may be designed and implemented accordingly. This study was mostly directed to learning styles and study habits individually. Future research may examine common effects of learning styles and study habits together on academic performances.



## References

- Akdemir, O., & Koszalka, T. A. (2008). Investigating the relationships among instructional strategies and learning styles in online environments. *Computers & Education, 50*(4), 1451-1461.
- Akkoyunlu, B., & Soylu, M. Y. (2008). A study of student's perceptions in a blended learning environment based on different learning styles. *Educational Technology & Society, 11*(1), 183-193.
- Allen, M., J. Bourhis, N. Burrell, & E. Mabry. (2002). Comparing student satisfaction with distance education to traditional classrooms in higher education: A meta-analysis. *The American Journal of Distance Education, 16*(2), 83–97.
- Ally, M., & Fahy, P. (2002, August). Using students' learning styles to provide support in distance education. *In Proceedings of the Eighteenth Annual Conference on Distance Teaching and Learning*, Madison, WI.
- Aragon, S. R., Johnson, S. D., & Shaik, N. (2002). The influence of learning style preferences on student success in online versus face-to-face environments. *The American Journal of Distance Education, 16*(4), 227-243.
- Aşkar, P., & Akkoyunlu, B. (1993). Kolb learning style inventory. *Education and Science, 15*(81), 37-47.
- Benbunan-Fich, R., & S. R. Hiltz. (2003). Mediators of the effectiveness of online courses. *IEEE Transactions on Professional Communication, 46*(4), 298–312.
- Chen, N. S., & Lin, K. M. (2002, September). Factors affecting e-learning for achievement. *In IEEE International Conference on Advanced Learning Technologies ( 9-12)*.
- Coffield, F., Moseley, D., Hall, E., & Ecclestone, K. (2012). *Learning styles and pedagogy in post-16 learning: A systematic and critical review*. Learning and Skills Research Centre: London.
- Cohen, J. (1988). *Statistical power analysis for the behavioral sciences* (2nd ed.) Hillsdale, NJ: Lawrence Erlbaum Associates.
- Coleman, P., Collinge, J., & Tabin, Y. (1993). *The Learning triad: Parental involvement*. London: University of North London Press.
- Crede, M., & Kuncel, N. R. (2008). Study habits, skills, and attitudes: The third pillar supporting collegiate academic performance. *Perspectives on Psychological Science, 3*, 425-454.



- Dağ, F., & Geçer, A. (2009). Relations between online learning and learning styles. *Procedia-Social and Behavioral Sciences*, 1(1), 862-871.
- Daniel, J. A. (1999). *Effects of learning style and learning environment on achievement of physical therapy graduate students in distance education* (Doctoral dissertation). Texas Tech University.
- Dringus, L., & Terrell, S. (2000). An investigation of the effect of learning style on student success in an online learning environment. *Journal of Educational Technology Systems*, 28(3), 231-238.
- Dunn, R., & Dunn, K. (1978). *Teaching students through their individual learning styles: A practical approach*. Reston, VA: Reston Publishing.
- Dziuban, C., Moskal, P., & Hartman, J. (2005). *Higher education, blended learning, and the generations: Knowledge is power: No more. Elements of quality online education: Engaging communities*. Needham, MA: Sloan Center for Online Education.
- Fahy, P. J., & Ally, M. (2005). Student learning style and asynchronous computer-mediated conferencing (CMC) interaction. *The American Journal of Distance Education*, 19(1), 5-22.
- Fearing, A., & Riley, M. (2005). Graduate students' perceptions of online teaching and relationship to preferred learning styles. *Medsurg Nursing*, 14(6), 383-389.
- Federico, P. A. (2000). Learning styles and student attitudes toward various aspects of network-based instruction. *Computers in Human Behavior*, 16(4), 359-379.
- Felder, R. M., & Silverman, L. K. (1988). Learning and teaching styles in engineering education. *Engineering Education*, 78(7), 674-681.
- Felder, R. M., & Soloman, B. A. (1997). Index of learning styles. Retrieved from <http://www.ncsu.edu/felder-public/ILSpage.html>
- Fleming, N. D. (2001). *Teaching and learning styles: VARK Strategies*. Honolulu Community College.
- Gardner, H. (1993). *Multiple intelligences: The theory into practice*. New York: Basic Books.
- Göğüş, A., & Güneş, H. (2011). Learning styles and effective learning habits of university students: a case from Turkey. *College Student Journal*, 586-600
- Gregorc, A. F. (1984). *Gregorc's style delineator: Development, technical, and administration manual*. Gregore Associates, Inc.

- Gregorc, A. F., & Butler, K. A. (1984). Learning is a matter of style. *VocEd*, 59(3), 27-29.
- Hamilton-Pennell, C. (2002). Getting ahead by getting online. *Library Journal*, 127(19), 32-35.
- Healey, M., & Jenkins, A. (2000). Learning cycles and learning styles: the application of Kolb's experiential learning model in higher education. *Journal of Geography*, 99(5), 185-195.
- Honey, P., & Mumford, A. (1986). *Using your learning styles* (2nd ed.). Maidenhead,, UK: Peter Honey.
- Hummel, H. G.-K. (2006). Feedback model to support designers of blended-learning courses. *International Review of Research in Open and Distance Learning*, 7(3), 1-16.
- James, W. B., & Gardner, D. L. (1995). Learning styles: Implications for distance learning. *New Directions for Adult and Continuing Education*, 1995(67), 19-31.
- Jonassen, D. H., & Grabowski, B. L. (2012). *Handbook of individual differences learning and instruction*. Routledge.
- Jung, C. G. (1970). *Analytical psychology, theory and practice, the Tavistock lectures*. New York: Vintage Books.
- Karademir, E., & Tezel, Ö. (2010). Examination of the learning styles of pre-service elementary teachers in terms of demographic variables. *Pamukkale University Faculty of Education Journal*, 28, 129-145.
- Kolb, A. Y., & Kolb, D. A. (2005). Learning styles and learning spaces: enhancing experiential learning in higher education. *Academy of Management Learning & Education*, 4(2), 193-212.
- Kolb, D. A. (1985). *Learning Style Inventory: Self Scoring Inventory and interpretation booklet*. Boston: McBer and Company.
- Liegle, J. O., & Janicki, T. N. (2006). The effect of learning styles on the navigation needs of Web-based learners. *Computers in Human Behavior*, 22(5), 885-898.
- Lippert, R. M., Radhakrishna, R., Plank, O., & Mitchell, C. C. (2001). Using different evaluation tools to assess a regional internet in-service training. *International Journal of Instructional Media*, 28(3), 237-248.
- Lu, H., Jia, L., Gong, S. H., & Clark, B. (2007). The relationship of Kolb learning styles, online learning behaviors and learning outcomes. *Journal of Educational Technology & Society*, 10(4).

- Manochehr, N.N. (2006). The influence of learning styles on learners in e-learning environments: An empirical study. *Cheer Virtual Edition*, 18, 10-14.
- McEwen, B. C. (2001). Web-assisted and online learning. *Business Communication Quarterly*, 64(2), 98-103.
- Miller, L. M. (2005). Using learning styles to evaluate computer-based instruction. *Computers in Human Behavior*, 21(2), 287-306.
- Mitchell, J. L. (2000). *The effect of matching teaching style with learning style on achievement and attitudes for women in web-based distance education course*. Terre Haute, IN: Indiana State University.
- Morris, K. V., Finnegan, C., & Sz-Shyan, W. (2005). Tracking student behavior, persistence, and achievement in online courses. *Internet and Higher Education*, 8(3), 221–231.
- Mupingo, D. M., Nora, R. T., & Yaw, D. C. (2006). The learning styles, expectations, and needs of online students. *College Teaching*, 54(1), 185-189.
- Neuhauser, C. 2002. Learning style and effectiveness of online and face-to face instruction. *The American Journal of Distance Education*, 16(2), 99–113.
- Patel, B. V. (1976). Study habits inventory. In D. M. Pestonjee, (Ed.), *Second handbook of psychology and social instruments*. Concept Publishing Company, New Delhi.
- Popescu, E. (2010). Adaptation provisioning with respect to learning styles in a Web-based educational system: An experimental study. *Journal of Computer Assisted Learning*, 26, 243–257.
- Proctor, B. E., Prevatt, F., Adams, K., Reaser, A., & Petscher, Y. (2006). Study skills profiles of normal-achieving and academically struggling college students. *The Journal of College Student Development*, 47, 37-51
- Richmond, A. S., & Liu, L. (2005). Student learning styles of traditional courses versus online distance courses. In C. Crawford, R. Carlsen, I. Gibson, K. McFerrin, J. Price, R. Weber & D. A. Willis (Eds.), *Technology & teacher education annual* (pp. 576-578). Charlottesville, VA: AACE.
- Robins, A., Rountree, J. & Rountree, N. (2003). Learning and teaching programming: a review and discussion. *Computer Science Education*, 13, 137 -173.
- Robinson, H. H. (2000). *Effective study*. New York: Harper and Brothers.

- Schellens, T., & M. Valcke. 2000. Re-engineering conventional university education: Implications for students' learning styles. *Distance Education*, 21(2), 361–384.
- Schmeck, R. R., Geisler, E., & Cercy, S. P. (1991). Self-concept and learning: The revised inventory of learning processes. *Educational Psychology*, 11, 343-362.
- Sharpe, R., & Benfield, G. (2005). The student experience of e-learning in higher education. *Brookes eJournal of Learning and Teaching*, 1(3).
- Shaw, R.S. (2012). A study of the relationships among learning styles, participation types, and performance in programming language learning supported by online forums. *Computers & Education*, 58, 111-120
- Simpson, C., & Yunfei, D. (2004). Effects of learning styles and class participation on students' enjoyment level in distributed learning environments. *Journal of Education for Library and Information Science*, 45(2), 123-136.
- Smith, P.L., & Ragan, T. J. (1999). *Instructional design* (2<sup>nd</sup> ed.). USA: John Wiley & Sons, Inc.
- Sun, K. T., Lin, Y. C., & Yu, C. J. (2008). A study on learning effect among different learning styles in a Web-based lab of science for elementary school students. *Computers & Education*, 50(4), 1411–1422.
- Terrell, S. (2002). Learning style as a predictor of success in a limited residency doctoral program. *The Internet in Higher Education*, 5(4), 345-352.
- Tseng, C. R., Chu, H. C., Hwang, G. J., & Tsai, C. C. (2008). Development of an adaptive learning system with two sources of personalization information. *Computers & Education*, 51(2), 776–786.
- Wang, K. H., Wang, T. H., Wang, W. L., & Huang, S. C. (2006). Learning styles and formative assessment strategy: Enhancing student achievement in Web-based learning. *Journal of Computer Assisted Learning*, 22(3), 207–217.
- Wang, T., Su, X., Ma, P., Wang, Y., & Wang, K. (2011). Ability-training-oriented automated assessment in introductory programming course. *Computers & Education*, 56(1), 220–226.
- Weinstein, C. E., & Palmer, D. R. (2002). *Learning and study strategies inventory (LASSI): User's manual* (2nd ed.). Clearwater, FL: H & H Publishing.
- Wolfe, D. A., Jaffe, P. G., & Crooks, C. V. (2006). *Adolescent risk behaviors: Why teens experiment and strategies to keep them safe*. New Haven, CT: Yale University Press.

Athabasca University 



## An Investigation into the Management of Online Teaching and Learning Spaces: A Case Study Involving Graduate Research Students



Rohan Jowallah  
University of Central Florida, USA

### Abstract

This research evaluates the strategies implemented to support the research activities of postgraduate students pursuing online master's programs in the University of the West Indies Open Campus, as well as the activities of their supervisors. The three main strategies employed were (1) the use of a web-based 'teaching-learning space' to facilitate asynchronous interaction between students and their supervisors; (2) the provision of a scheduling tool to facilitate the planning of one-on-one meetings via a synchronous web-conferencing tool; and (3) the organization of research seminars using the same web-conferencing tool.

This research used Moore's theory of transactional distance and social cognitive theoretical framework to guide the project. Moore's model reemphasizes the need for stronger forms of communicating for online students, whereas the cognitive framework focuses on the need for social interaction among learner and teacher. Participants were graduate students ( $n = 34$ ). All participants were required to complete a questionnaire online. Data were also collected from postings in discussion forums. Overall, notwithstanding limitations, the data shows there are benefits to be gained from conducting student research activities in an online environment.

**Keywords:** Online interaction; higher education; asynchronous and synchronous communication

## Introduction

The past decade has seen the rapid development of online educational programs in universities. One reason for this increase is the growth of the Internet and technological advancements that support online learning spaces (Johnson & Aragon, 2003). Traditionally, students who engaged in a research unit for their degree were assigned a research supervisor with whom they met one-on-one face-to-face. In addition, students could attend informal meetings with their supervisors and fellow students within a physical location. The lack of one-on-one face-to-face within the online learning environment requires universities to be innovative in creating interactive learning spaces to support research students within the online environment. In responding to the need for creative and interactive learning spaces, many universities have used various technological tools.

By employing these technological tools, many institutions have "...developed innovative learning strategies..." (McPherson & Baptista, 2004, p. 148). These "innovative learning strategies" have created flexible methods of delivery for courses (Ragan, Lacey, & Nagy, 2000), opportunities for the delivery of courses by highly qualified staff (Banks, Moon, & Wolfenden, 2009), and have given students a high quality of education without geographic restrictions. Furthermore, the introduction of these ground-breaking technologies has created an ideological transformation for the educator for the conceptualization and development of knowledge online (Mok & Cheng, 2000). Mok and Cheng (2000) view this change as the "demonopolisation of teaching" which is the shifting from the 'teacher focus approach' to the 'studentcentered learning approach'. Therefore, it will be imperative for universities to consider how they will use new technologies to enhance online pedagogy to improve support for research students.

### The Context of the Research Problem

The UWI Open campus came into existence four years ago after major restructuring with other sectors within The University of The West Indies. In January 2010, The UWI Open Campus enrolled over seventy students in its online Master's Literacy Program. For the completion of a Master of Education degree, students were required to complete a research project.

For the research component, all students were assigned a research supervisor (RS); each research supervisor was assigned four students. As supervisors, they were responsible for supporting the students' research agenda, guiding the research process, and aiding students in their research management. An assigned research coordinator provided quality assurance and supervision.

During the third week of the research course, the researcher conducted a small online survey that solicited concerns from 34 students. The data collected was analysed using themes; the following themes emerged: the need for improved research supervisor's support, time management, understanding the research process. Based on the findings

from the survey, the researcher supervisors met on three occasions to decide on an appropriate means to address students' concerns. The consensus was that research supervisors plan and implement asynchronous and synchronous communication to encourage interaction between themselves and their students. This form of interaction should take place within an online forum with live discussion with their group of students, one-to-one meetings with students, and compulsory participation of students in live research proposal seminar presentations.

## Significance of the Problem

There is a need for online social interaction especially within the context of universities that are moving their degree programs online. Many universities have neglected to ensure that courses delivered online have adequate interaction for the construction of knowledge. The implementation of technological tools can strengthen interaction; however, technology must be used within the framework of planned human interaction. Without planned human interaction, various gaps will be created that could hinder the learner and instructor. Consequently, it is essential that activities are planned to simulate social interaction online. Wei et al. (2012, p. 529) state "... social presence has significant effects on learning interaction that in turn have significant effects on learning performance."

This research is important because it focuses on the need for course instructors to be proactive and make changes in their mode of delivery to address gaps in their instructional approach for increased interaction within the online learning environment. This study could also prove to be a starting point for many universities seeking to enhance their online courses and improve online interaction.

Finally, The UWI Open Campus is a new organization; therefore, it is important to find innovative methods to respond to the diverse learning needs of the students who are located in various Caribbean countries. It is the researcher's view that this should be done in a responsible manner using research as a means to evaluate strategies. The researcher used the research questions below to guide the examination and evaluation of the strategies implemented in the online learning environment.

## Research Questions

- In what ways did setting up synchronous and asynchronous tools improve the learning experiences of online research students?
- How did the inclusion of asynchronous and synchronous tools improve interaction between students and their research supervisors?
- What were some of the difficulties experienced by students in using the asynchronous and synchronous interactive strategies employed to support them?



## Theoretical Frameworks

A social cognitive theoretical framework guided the research. According to Yanghee and Baylor (2006), "Social-cognitive theories highlight that teaching and learning are social activities and that involves interaction with teachers, peers, and instructional materials that influence the cognitive and affective development of the learners". The above mentioned framework makes direct connections to the need for social interaction between the learner and the instructor. Based on this framework the researcher designed the research process within this social context and need for interaction. This need for interaction is affirmed by Perkins (2001) who postulates that strategies implemented without giving consideration to the social-cognitive dimension of learning will not achieve its objectives. Seminal psychologists such as Piaget and Vygotsky affirm that interaction is fundamental to the learning and development process (Yanghee & Baylor, 2006). The research also utilized Moore's theory of transactional distance, which suggests that distance learning could lead to gaps that could create potential barriers between the learner and the instructor (Moore & Kearsley, 1996).

## Literature Review

Online learning technological advancements allow facilitators and students to work collaboratively within the learning environment. Such collaborative learning promotes the construction of knowledge. In spite of these benefits, however, there is resistance to the development of online delivery by some academics. This resistance may be the result of a lack of expertise to conceptualize and develop the online environment (Zhao et al., 2002); ideological assumptions that teaching cannot be done using the online format (Baecher, 2011); or the lack of allocated training time to develop the required skills (Vannatta, 2000). When initiating the online delivery of any program, developers must acknowledge that a different level of proficiencies for instructors than what is required in the face-to-face traditional approach will be necessary. These proficiencies will require online tutors to be creative teachers who are supportive of the learner, skilled in monitoring the learning environment, able to motivate and stimulate the learner, and able to create critical learning interaction between themselves and their students (Fein & Logan, 2003). Furthermore, today's learners are able to access various technologies that will allow them to retrieve information in 'real time.' Consequently, it will be essential for universities to develop "a style of education that excites and engages students..." (Girard et al., 2007, p. 46).

Educators who have found effective ways to promote exciting and engaging education incorporate synchronous and asynchronous forms of communication (Girard, 2007). The fusion of both communication forms could lead to greater virtual collaboration between the facilitator and the learners and construct a community of producers of knowledge. Leung et al. (2007) validate the inclusion of both synchronous and asynchronous by stating that both systems provide "complimentary ways of communication and interactions for different teaching and learning principles" (p. 634).

Some academics suggest that within the online learning environment interaction and socialization between teachers and learners are limited. Such views do not take into account the technological advancements of ICTs and their capacity to support meaningful learning both individually and interpersonally. These improved technological advancements have also enhanced the social presence needed online, improved instructional effectiveness, and helped instructors and their students to work collaboratively (Aragon, 2003). McLennan (1999) describes social presence as “the degree to which participants are able to project themselves effectively within the medium” (p. 40). Gunawardena and Zittle (1997) simplify McLennan’s description by stating social presence is “the degree to which a person is perceived as a ‘real person’ in mediated communication” (p. 9).

The development of social presence online creates a comfort zone for learning, increases informal and formal exchange, increases the inclusion of learners, improves collegial interaction, and enhances cognitive interaction within the online learning environment (Whiteman, 2002; Newberry, 2001; Rourke et. al., 1999). Importantly, Aragon (2003) warns that individuals who are separated by physical or geographic distance are at risk of having limited social presence; therefore, attention should be given to social presence within the online learning environment to avoid negative consequences.

## Methodology

### Research Sample

All students enrolled in the class were asked to participate in an online questionnaire; 34 of the 70 students completed the questionnaire. All data collected had non-identifiers to ensure anonymity. Data was also collected from the online learning environment, specifically the learning exchange, throughout the course which lasted seven months. Influenced by a social cognitive theoretical framework and Moore’s theory of transactional distance, the researcher chose the case study design to guide the research process.

Both approaches lend themselves to the exploration of socially constructed data. By using the case study design, the researcher was able to use the qualitative method of data collection to solicit the perspectives of participants in relation to their online experiences. Data was also collected in quantitative form from the questionnaires. By combining both forms of data, the researcher was able to offset the limitations associated with qualitative and quantitative methods of data collection. The researcher is also aware of the limitation associated with the generalization of these findings and the high level of subjectivity associated with undertaking a case study design.

Consequently, the researcher took procedures to ensure that the instrument used was valid.

Based on the timeframe available for this study and the nature of the study, the researcher decided to maximize the use of online questionnaires for the research students. The questionnaires were designed to gain open responses rather than closed. A second source of data collection included the students' forum and recorded seminar sessions. The researcher had intended to conduct in-depth interviews, however, upon deliberation, decided that the interviews should be implemented at the end of the students' final trimester.

### Analysis of Data

Thirty-four students completed the online questionnaire. All qualitative responses were placed into Weft QDA, an online, free, open-source tool used in the analysis of qualitative data. Once the data was uploaded, the researcher coded data into emerging themes. Upon completion of the coding process, the data was placed within a table designed to include quantitative data where appropriate. The inclusion of this table allowed the researcher to analyze both modes of data collection within the same spaces. This process provides more depth to the data collected.

## Results and Discussion

Highlights of the dominant themes that emerged during the analysis of data are described below.

### Theme I: Learning Experiences of Online Research Students

Data analysis established that both synchronous and asynchronous communication forms enhanced the learning experiences among students. Based on the comments from students, the use of asynchronous communication kept them up-to-date with their course expectations, resolved their fears, helped them to connect socially with their research supervisor, and provided beneficial feedback. Table 1 offers samples of students' responses in relation to the use of an asynchronous mode of communication. The responses suggest that the social presence of the research supervisor had an impact on the learning interaction experienced by students (Wei et al., 2012).

Table 1

*Comments from Students on the Use of Asynchronous Mode of Communication*

Student A	The communication process kept me on course.
Student B	Because of the feedback given, I was able to make the necessary corrections which helped me to advance my project.
Student C	My supervisor quieted my fears and gave me advice when it was necessary. She also commended me when she was pleased with the direction I was taking.
Student D	Communicating with my supervisor via email appears more personal and effective than via forums. It is often easier to check your e-mail than to log into the website, and then search the forum for current info.
Student E	I received prompt and beneficial feedback.

The data also established that the implementation of the synchronous mode of communication had significant benefits. For example, 30 students believed that the seminar presentation motivated them and kept them focused on their research projects. Despite this positive feedback, however, four students believed the seminars did not motivate them or keep them focused; external or internal factors could have influenced these perspectives. Additional research would be beneficial to establish the possible factors delimiting these students' motivation.

Combining both forms of communication proved beneficial. For example, the use of email and online discussion (asynchronous) provided a platform for individualized attention. The finding corroborated the idea put forward by Girard et al. (2007) that suggests that the fusion of both forms of communication (asynchronous and synchronous) could lead to greater virtual collaboration within the online learning community. This form of collaboration will be essential in providing students the sustaining communication within the learning environment that could enhance students' learning experiences. Importantly, it should also be noted that sustained communication could improve the social presence in the learning environment that could also result in the construction of knowledge within the learning community (Rockinson-Szapkiw, 2009).

The need for interaction within the learning environment is essential for the construction of knowledge (Rockinson-Szapkiw, 2009). Consequently, it is imperative that online discussions and email responses are humanized and developed to allow maximum interaction. To enhance the interaction, live seminar sessions were implemented. The data collected suggested that the implementation of these sessions improved students' experiences and helped motivate students as they developed their research projects. Table 2 highlights three dominant themes that emerged from the data in relation to the implementation of live seminar sessions.

Table 2

*Showing the Dominant Themes that Emerged with the Implementation of Live Online Seminar Sessions Using Blackboard Collaborate*

Themes	Students' comments
Interaction	<p>Interaction among peers is important, "misery loves company", but good to know our shortcomings exist and learn from one another in rectifying them.</p> <p>Interaction with colleagues. This aspect was lonely. I was unable to communicate with colleagues from other groups, so these live meetings made the course feel alive and human.</p> <p>It was nice hearing the voices of other participants.</p> <p>I learned to use the Illuminate setting. It was comforting hearing the voices of colleagues and my supervisor</p>
Knowledge building	<p>Clarification with areas of doubt.</p> <p>Meaningful feedback from supervisor and classmates .</p> <p>An opportunity to communicate verbally with the group New ideas on how to proceed.</p> <p>I was able to understand more clearly the concepts involve in research methods.</p> <p>Measure my progress as it relates to my colleagues. Garner the support needed to move forward.</p> <p>I was able to receive immediate feedback from my supervisor and constructive criticisms from other students. I was also able to give feedback to other students. There was great clarity on the way forward having participated in online meetings</p>
Response time	<p>Being able to ask questions and receive immediate feedback.</p> <p>Immediate responses to my questions.</p>

On reflection, the synchronous mode of communication enhanced the learning experiences of online research students. The data in the table suggests that synchronous sessions can enhance student experiences by providing spaces for interaction. Ultimately, the design of these live sessions improved social presence and created a zone for learning and enhanced the intellectual exchanges within the learning environment (Whiteman, 2002; Newberry, 2001; and Rourke et al., 1999).

## Theme II: Improving Interaction

The issue of communicating online was also examined in this research. Twenty-nine percent of the students who did the survey stated that they found the online learning environment challenging. Based on the data collected, students had technical problems and difficulties with communicating with their research supervisors at some point during the course. For online students, this level of support is essential to keep them motivated and focused on their research project, particularly in the Caribbean where Internet service is not consistent.

The data analysis established that all research supervisors supported their students in the preparation of their online presentations (two sessions were held). However, it became apparent that this support was not consistent for both planned sessions held in June and October. In June, the seminar sessions were compulsory, but, in October, the guidance given to both supervisors and students did not indicate that the seminar sessions were compulsory. Therefore, some supervisors and students may have approached the second seminar in a more casual manner. Regardless of this discrepancy between the level of support given to students in seminars one and two, it is clear that 30 (88%) of the students were satisfied with the level of support given throughout the research process. Four (11%) of the thirty-four students believed that this support was inadequate. In a follow up statement on support, students were asked whether or not communication with their supervisors assisted with their research progress. Four of the thirty-four students indicated that online communication did not assist them with the research process.

The inclusion of the live online learning session created various opportunities for the students. Thirty of the thirty-four students agreed that the October seminar sessions helped motivate them and kept them focused on their research project. The issue of motivation is essential for the online learner because most of our online students are from different geographical regions of the Caribbean.

In contrast to earlier findings in the live online session, students who responded to the benefits of using email and online discussion made limited connections to social interaction within their responses. Since teaching and learning is a social activity, it is important to engage students and sustain this level of engagement (Yankee & Baylor, 2006). As a result of this finding, strategies will be developed to foster better interaction in the online environment between research supervisors and their students to prevent students from feeling isolated. Kelly (2012) highlights this importance by stating that the humanized classroom leads to improved learning experiences, student accomplishment, and student retention. Moore and Kearsley (1996) stress that the learning space address the possible gaps between the learner and the instructor to develop interaction.

## Conclusion

One of the significant findings to emerge from this study is that the inclusion of synchronous and asynchronous strategies improved the learning experiences and interaction among research students and their supervisors by creating social interaction; these sessions also created the space for interaction between all 17 groups involved in writing their research projects.

The study has also shown that interaction with online research students will require different skill levels and aptitude to simulate and motivate students within the online learning environment. According to Fein and Logan (2003), online tutors need to be creative, have the ability to motivate and monitor their students, and help their students develop into critical learners so that they may provide “a style of education that excites and engages students” (Girard et al., 2007, p. 46).

Evidence from this study suggests that the preferred method of feedback for most students is email; therefore, research supervisors need to improve their support when using this form of communication. Live seminar sessions also benefitted students. Analyzed data established that the seminar sessions allowed the building of confidence within the learning environment and created a structure for students to manage their work effectively; some students also used these sessions to assess their own work and research progress.

The implementation of the synchronous and asynchronous strategies created a structure for the research coordinator to obtain ongoing feedback on students’ progress and the support given by research supervisors. Therefore, the research coordinator should standardize the procedures used to ensure that the strategies employed become common practice when monitoring students and their supervisors online.

The research results also established that the synchronous and asynchronous strategies helped develop intellectual learning spaces for students. These learning spaces (online discussions and live web conferences) created a place for students to engage in discourses relevant to the research process. Research supervisors, therefore, should encourage student participation in all online discussions and web-based conferences. Additional web-based conferences could be a key tool in motivating and managing students’ research projects.

In general, most research supervisors were supportive, although four students indicated that they had an unsupportive supervisor. Based on this finding, the research coordinator will need to create a monitoring tool with a design that addresses issues relating to student support.

The technological difficulties experienced by some students included the inability to log on for the live conference sessions, which could have affected their ability to communicate online and impeded their learning.

This research has highlighted the importance and the need for a standardized use of synchronous and asynchronous strategies for monitoring students' and research coordinators' interaction and the development of online learning spaces to manage students' progress at various points in the research process. These findings also highlight the need to increase the number of online discussions and live presentations during the graduate research project course. The author recommends that further research solicits data from the research supervisors about their perception of synchronous and asynchronous strategies.



## References

- Banks, F., Moon, B., & Wolfenden, F. (2009). New modes of communication technologies and the reform of open and distance learning programmes: A response to the global crisis in teacher education and training. In *23rd ICDE World Conference on Open and Distance Learning*, 8-10 June 2009, Maastricht, The Netherlands. Retrieved from <http://oro.open.ac.uk/18345/>
- Baecher, H. (2011). The online “supplemental” workshop: Course enrichment to support novice teachers’ analysis of classroom video. *Merlot Journal of Online Learning and Teaching*, 7(1), 108-117.
- Fein, A., & Logan, M (2003). Preparing instructors for online instruction. In R. Aragon & J. Bass, *Facilitating learning in online environments*. San Francisco: Wiley Periodicals.
- Girard, J., Willoughby, L., & Berg, K. (2007). Video, voice and virtual collaboration: The 3v’s of asynchronous education . In Buzze-More, *Principles of effective online teaching*. California: Informing Science Press.
- Johnson, S., & Aragon S. (2003). An instructional strategy framework for online learning environments. In R. Aragon R & J. Bass, *Facilitating learning in online environments*. San Francisco: Wiley Periodicals.
- Perkins, D. N. (2001). Person-plus: A distributed view of thinking and learning. In G. Salomon (Ed.), *Distributed cognition: Psychological and educational considerations* (pp. 88–110). Cambridge University Press.
- Kelly, R. (2012). Tips for humanizing your online course. *Online Classroom*, 4-5.
- Leung, H., Li, Q., & Lau R., (2006). *Advances in web based learning*. ICWL 5<sup>th</sup> International Conference, Penang, Malaysia, July 19-21
- McPherson, M., & Nunes, M. (2004). *Developing innovation in online learning: An action research framework*. London: RoutledgeFalmer.
- Mok, M., & Cheng, Y. (2000). Global knowledge, intelligence, and education for learning society. Invited plenary speech at the 6th UNESCO-ACEID International Conference “information Technologies in Educational Innovation for Development: Interfacing Global and Indigenous Knowledge”. Thailand.
- Newberry, B. (2001). Raising student social presence in online classes.” In WebNet 2001. *Proceedings of the World Conference on the WWW and Internet*. Norfolk, Va.: AACE

- Ragan, P., Lacey, A., & Nagy, R. (2002). Web-based learning and teacher preparation: Stumbling blocks and stepping stones. *Teaching with Technology Today*, 8(5). Retrieved from <http://www.uwsa.edu/ttt/articles/ragan.htm>
- Rourke, L., Anderson, T., Garrison, D., & Archer, W. (1999). Assessing social presence in asynchronous text-based computer conferencing. *Journal of Distance Education*, 14(2), 50-71.
- Zhao, Y., Pugh, K., Sheldon, S., & Byers, J. (2002). Conditions for classroom technology innovations. *Teachers College Record*, 104(3), 482-515.
- Vannatta, R. (2000). Evaluation to planning: Technology integration in a school of education. *Journal of Technology and Teacher Education*, 8(3), 231-246.
- Wei, C., Chen, N., Kinshuk. (2012). A model for social presence in online classrooms. *Educational Technology Research And Development [serial online]*, 60(3), 529-545. Available from ERIC, Ipswich, MA.
- Yanghee, K., & Baylor, A. (2006). A social-cognitive framework for pedagogical agents as learning companions. *Association for Educational Communications and Technology*, 8(54), 569-596.

Athabasca University 



## Two Perspectives on E-Learning Design: A Synopsis of a U. S. and a European Analysis



Stefanie A. Hillen<sup>1</sup> and Melodee Landis<sup>2</sup>

<sup>1</sup>University of Agder, Norway, <sup>2</sup>University of Nebraska at Omaha, USA

### Abstract

This article seeks to examine e-learning design arising from two educational traditions: the United States of America and Europe. The research question is: Broadly, what kinds of pedagogy, instructional design models, or didactical models are established and proposed for e-learning design on the two continents? Two researchers examined multiple articles and texts in an effort to discern the prominent approaches in their respective regions. The analysis is tripartite: First, the educational philosophies, which have guided e-learning design on each continent, will be presented; second, specific theories about learning influencing e-learning design will be discussed; and finally, e-learning design, which arises from innovative instructional strategies, will be investigated. The resulting analysis brings to the surface not only how the values that underpin e-learning development in each region differ but also how specific perspectives influence the respective fields. The researchers acknowledge these differences but also remark on the historic and contemporary symbiosis that has endured even in this relatively new field of e-learning.

**Keywords:** E-learning design; instructional design; educational philosophies; media-didactics; general didactics

## Introduction

For those who undertake the design of e-learning experiences, navigating through the multiple approaches and models can be daunting. It is hoped that, by studying the various approaches and comparing them across the continents, we can gain some insight into the overarching schools of thought that have been driving e-learning design. Thus, the purpose of this paper is to compare how two analysts view e-learning design in their respective regions: the United States and Europe.

The analysts focus on those interactions among students, teachers, and the subject matter respectively that are supported, enabled, or guided by electronic technology. This includes both synchronous and asynchronous approaches.

To gather data, the authors each conducted extensive searches of existing periodical literature and consulted numerous texts on instructional technology working to identify the underlying theory and guiding principles used by e-learning designers in their respective spheres of operation. Nearly two hundred publications, electronic and print, were examined using a grounded theory approach to analyze the data. The U.S. information was analyzed by a scholar experienced in instructional design; the European material was analyzed by an expert in media and comparative education. These two perspectives are evident in the reports and will be considered in the resulting analysis.

## Framework for the Analysis of European and U.S. E-Learning Design

To compare the approaches and processes used in the two countries, the levels of research activity articulated by Arthur Ellis and Jeffrey Fouts in their book *Research on Educational Innovations* (1997) were helpful. An adaptation of their levels of research, spanning from philosophies to theories to practice, has been created to organize this study. Since broad educational philosophies have served as the basis for instructional design in both regions, they will be discussed first. Then the content in each region will approximate a general to specific approach as follows:

### U.S.

- How educational philosophies have guided e-learning design in the U.S.
- Specific theories and models influencing e-learning design in the U.S.
- E-learning design arising from innovative instructional strategies in the U.S.

## Europe

- How educational philosophies have guided e-learning design in Europe
- Specific theories and models influencing e-learning design in Europe
- E-learning design arising from innovative instructional strategies in Europe

As the authors applied this tripartite structure, they found they needed to adapt to the specific educational traditions and philosophies of the data they uncovered. This led to subtopics that are themselves revealing. It must be stressed that these analyses are made from the viewpoints of each of the authors in the hope they will shed some light on general approaches used on each continent.

## Philosophies and Broad Learning Theories Beneath E-Learning Design

Many principles guiding today's e-learning design spring from Europe's and America's common heritage over the centuries. While these schools of thought are not specific to e-learning, they have deeply influenced all instructional design. From the philosophical roots of idealism, realism, and existentialism established by such philosophers as Plato and Aristotle through the existentialism and empiricism of Sartre and Kant, three broad learning theories appear most commonly in the literature: behaviorism, cognitivism, and constructivism. It is assumed that most readers are familiar with the tenets of these philosophies so this analysis will concentrate on how they appear to manifest in e-learning design.

## E-Learning Design in the U.S.

### How Educational Philosophies have Guided E-Learning Design in the U.S.

In the United States, the progression of e-learning design in recent decades appears to have roughly progressed from behaviorism to cognitivism to constructivism. Early on, computers were used as a supplemental way to reinforce teaching. First efforts stressed behaviorist approaches such as drill and practice activities and quizzes corrected by the computer. It was common to present expository slides that used images and simple language to introduce the learner to content, then to follow that with quiz questions calling for the user to select an answer. Correct answers prompted rewards such as rudimentary images or sounds. Incorrect responses were rejected or looped the learner back to the expository slides to cover the content again. Out of this evolved more

sophisticated, independent learning systems. These systems sought to differentiate learning by branching to the most appropriate next step after each response (Squire, Johnson, & Bichelmeyer, 1998).

The behaviorist and cognitivist approaches were largely co-mingled in early e-learning. Content was logically organized (cognitivist) and learners were led through the material using operant conditioning techniques along the way (behaviorist). The rise of the “information processing” approach complemented the capability of the computer as an information management system (McLeod, 2008).

Cognitivists were impressed with the computer’s power to more vividly illustrate material through graphic images and highly structured simulations/situations. Discussion groups were also introduced during this period though conversations were often confined to specific questions. Most early e-learning courses were highly structured along content lines. In most online courses, learners were guided through the same path of learning in order for them to acquire the knowledge as organized and prescribed by the e-learning designer(s). No differences were made between learners’ needs or prerequisites. Today, this phenomenon is captured by the idea of individualization (personalization) in e-learning.

The constructivist push came as more flexible mind-mapping tools and social networking possibilities became prevalent. Some designers broke from the strictures of traditional cognitivism to become more learner-centered using individual and group tools for digesting and organizing information. The constructivist approach is still evolving but generally involves more activities that call for the learner to research, organize, and communicate as they learn, often choosing their own sources and products along the way. Though most e-learning today is still highly structured by content, some designers are seeking to provide alternate routes to achieve higher levels of autonomy, comprehension, and critical analysis.

The move away from defining learning as knowledge acquisition and organization to the development of functional skills and judgment has deepened what American scholars require of e-learning designers. No doubt, technology’s power is somewhat responsible for this deeper agenda.

## Specific Theories and Models Influencing E-Learning Design in the U.S.

The lines separating educational philosophies, learning theories, and planning models are often difficult to discern. There are, however, a few theoretical approaches that are noteworthy because they are frequently cited by those developing modern e-learning design models.

### **Situationist perspective.**

As Erica de Vries (2003, p. 161) states, “Today, different theoretical perspectives on learning and instruction co-exist partly inspired by technological developments.” To the behaviorist, cognitivist, and constructivist perspectives, she adds the “situationist perspective”.

The situationist perspective on learning highlights the idea that the learned knowledge has to be used in real life (Brown, Collins, & Duguid, 1989). According to the proponents of the situationist perspective, authentic activities, that is, the ordinary practices of a domain culture rather than traditional classroom activities, are needed for knowledge to be constructed in a form that will be exploitable in the future (Lave & Wenger, 1991, p. 163). The tenets of situationism are popular in some e-learning design models that appear in American literature.

### **Chaos theory.**

One other broad approach that bears discussion is chaos theory. Educational designers with this perspective perceive the full complexity of the learning environment, the instructor(s), the content, and the learners (Lorenzen, 2008). The intent is to remind designers that it is virtually impossible to plan for all variables in a learning situation and trying to control them may in fact inhibit learning. Supporters of chaos theory join the situational learning advocates in promoting the design of learning activities that resemble real-world experiences (Gollub & Solomon, 1996). Simulations, gaming, problem-based learning, and project-based learning are receiving increased attention by e-learning designers who ascribe to the chaos perspective.

### **Information processing theory.**

Many e-learning designs still hold to the “teaching as delivery” model when designing e-learning programs (de Vries, 2003). These designers consider learning to be the intake of information through the well-designed presentation of information using media designed to enhance the perception process (p. 160). One perspective on this approach is the “elaboration theory” developed by Reigeluth (1987, 1999), who proposes three organizations for designing content:

- the conceptual elaboration sequence (when there are many related concepts to be learned),
- the theoretical elaboration sequence (when there are many related principles to be learned), and
- the simplifying conditions sequence (when a task of at least moderate complexity is to be learned).

### **Cognitive load.**

This theory warns that overloading the brain with too much information can be counterproductive (Sweller, 1999). This is at odds with some of the extravagant multimedia productions and excessive hyperlinking. The dual processing theory by Schneider and Shiffrin (1977) portrays the mind as having two modes of functioning, automatic and controlled, and has become the basis for research on whether and how multimedia can enhance learning. For example, research by Mayer and Moreno (1998) found that learners could assimilate words and pictures better when using their dual processing (auditory and visual) capabilities. It seems comprehension is enhanced when the words are presented auditorily rather than visually. Clark and Mayer's studies (2011) and those of others (Baylor & Kim, 2005; Jones, et al., 1994) have used new research on perception and retention to establish many other reliable principles for multimedia design.

### **Cooperative learning theory.**

The large body of cooperative learning research by the Johnson brothers (1988, 1994) and others have had a significant impact on the design of e-learning as well. As the internet has become more ubiquitous, designers have incorporated more instructor-learner, learner-learner, and expert-learner interaction through the use of discussion boards, group work, and chat functions.

### **Generative learning theory.**

The Cognition and Technology Group at Vanderbilt (1991, NA) called for designs that respond to their generative learning theory. This perspective acknowledges the importance of building on the past learning experiences of the individual learner by providing learning situations that call for experimentation, creativity, and open-mindedness. The group's work calls for situated cognition, anchored in real-life replications (Cognition and Technology Group at Vanderbilt, 1990, 1991). One example was the Adventures of Jasper Woodbury, a series of adventures provided on an optical video disc (Nipper, ND) with realistic video and specialized technology that challenge students to analyze data, define problems, formulate strategies, and implement solutions.

### **Instructional design models.**

The most common term used in the United States to describe a prescriptive, methodical approach to planning teaching and learning experiences is instructional design (ID). Many instructional design models work to classify and encompass nearly all variables involved in the instructional process prior to instruction. The field is so broad that many American institutions of higher education offer entire programs of study in instructional design. Gustafson and Branch (2002) offer a general description that seeks to encompass the many forms of the process: "Instructional design is a system of procedures for developing education and training programs in a consistent and reliable



fashion. Instructional design is a complex process that is creative, active and iterative” (p. 17).

The systematic procedures developed by such theorists as Smith and Ragan (1999), Dick et al. (2004), and Morrison, Ross, and Kemp (2004) are complex and rigorous; these models work to guide the designer to anticipate almost all possibilities, before and during instruction.

Gustafson and Branch (1997) discovered that instructional design models have at least four components: analysis of the setting and learner needs; design of a set of expectations for an effective, efficient and relevant learner environment; development of all learner and management materials; and evaluation of results of the development (formative and summative) (p. 8f).

In keeping with behaviorist and cognitivist philosophies, there is the underlying assumption that one can anticipate learners’ behaviors or cognitive processes and pre-design their learning. ID proponents claim the method produces a well-organized, systematic course of study using the technology. While much of the work is done ahead of the presentation of a course, teacher reflection and adjustment is also encouraged throughout the process.

ID is not without critics, however. Some contend that design of some types of instruction before experiencing the learning environment and experimenting with the actual learners is premature (Hokanson & Miller, 2009). Others maintain systematic instructional design creates study that is inflexible and directed to superficial learning goals (Prensky, 2001; Rowland, 1992). Another obvious drawback cited by critics is the amount of time and effort involved in approaching design this way.

### **Rapid prototyping.**

Another approach that has been gaining traction among those designing for electronic media is that of rapid prototyping. This process works to address the shortcomings of traditional instructional design by sketching a preliminary framework and then dynamically gathering information as instruction occurs.

The process is described as ‘iterative’ since it advocates early testing of activities, often starting with ‘low tech’ experiments before moving to other media (Piskurich, 2006). Richard Culatta (2011) has sketched the difference between classic instructional design and rapid prototyping (see Table 1).

This trial and error method of development appears to be especially relevant for learning programs that rely on animation, artificial intelligence, and complex interactions between the material and the learner. Those who produce advanced digital learning materials attest to the speed and cost-saving advantages of the model (Creative Industries Research Institute, 2007).

Table 1

*Classic Instruction Design and Rapid Prototyping*

Classic design	Rapid prototyping
1. concept definition	1. concept definition
2. requirements definition	2. implementation of a skeletal system
3. preliminary design	3. user evaluation and concept
4. detailed design	4. implementation of refined requirements
5. code implementation	5. user evaluation and concept refinement
6. test and acceptance	6. implementation of refined requirements
7. [gripping because you now realize that there was something that got left out back in step 2]	7. [etc., etc., in a continuous cycle]

## E-Learning Design Arising from Innovative Instructional Strategies in the U.S.

Some advocates of e-learning design base their methods on innovative or research-proven instructional strategies. The last few decades have been an exciting time of experimentation stimulated by the promise of emerging digital and Web-based technologies.

### **Problem-based learning.**

The work of David H. Jonassen has promoted the use of technology applications as 'mind tools'. He points to the many ways blogging, concept-mapping, presentations, image creation, and social media can be used to inspire individual reflection and analysis as well as group discussion and collaboration. Jonassen sees power in organizing reality-based problems for learners to attack. He feels learning is deepest when students are part of investigatory teams in which they have a defined role (Howland, et al., 2011; Jonassen, 2011, 2006, 2000; Jonassen, Carr, & Yueh, 2007).

### **Virtual worlds, field trips.**

More and more virtual spaces are being created to provide simulations of authentic learning experiences that are being sought by those stressing reality-based, situated learning. From macro-contexts to micro-worlds, designers are working to create online environments where learners can create alter egos (avatars), explore exotic places, and interact with others from around the world (Schank, 1997). As examples, the application of 'Second Life' can be named. Such an approach is offered by the Seminole County Public Schools (SCPC, 2014). "Virtual worlds might be useful tools in online teaching because of their ability to engage students in interactions to build a sense of

community in classes ...” (Baker et al., 2009). Moreover, virtual worlds create a learning environment where experiences can be made which are otherwise too dangerous or too time- or cost intensive, or they can change pupils’ established roles by choosing an avatar’s role, which might lead to different or expanded learning experiences.

### **Gaming and simulations.**

There is a growing community of e-learning designers who are convinced that gaming and simulations are especially suited to today’s youthful learners (e.g., Prensky, 2001). They label many of the traditional e-learning design methodologies as static approaches that disregard how contemporary youth process information, using click games, apps, and simulations. They defend the glitzy, rapid-paced, thrilling effects as effective ways to motivate modern learners. Some of these designers provide suggestions for design principles as well (Deterding, 2013). Cohen’s (2011) approach is the gamification of education. He stresses that online social games may be poised to replace textbooks in schools. Examples he refers to are the PBS KIDS’s interactive whiteboard games, which teach basic subjects to very young children, and the Learning Company’s hugely popular historical learning game, *The Oregon Trail* (Cohen, 2011, p. 16). An approach named ‘Quest to Learn’ (Thomas & Brown, 2011) is used for example in New York City public charter schools, which has practically eliminated textbook-based learning and largely replaced it with game-based learning. The key for successful learning is seen in rule-based learning systems, in which players actively participate, and use strategic thinking to make choices, solve complex problems, seek content knowledge, receive constant feedback, and consider the point of view of others (Cohen, 2011, p. 17). This applies for adult and professional training situations too.

### **Communities of learning.**

Pursuant to existing research on cooperative learning, many designers have exploited the tools of social networking, often calling for online groupings or communities of learners. Course management systems and Web tools provide ample opportunities for using chats, discussion boards, Facebook-like sites, or blogs in online courses. The notion of providing a community of learners and guided discovery advocated by Ann Brown and others has given rise to the creation of virtual learning spaces that encourage constant and effective collaboration in online learning activities (Brown & Campione, 1994). Current research focuses on effective strategies raising questions on technical and social prerequisites to build and support these kinds of learning communities (Charalambos, Michalinos, & Chamberlain, 2004; Carlén & Jobring, 2005; Palloff & Pratt, 2007).

A survey about K–12 online learning in 2007 came to one general conclusion: The trends of online learning which can be observed in postsecondary education that approximately three million students are enrolled in fully online courses or blended courses will follow in private as well as in public primary and secondary education too (Picciano & Seaman, 2007). A follow up study in 2009 confirmed this assumption. The result was that the overall number of K–12 students engaged in online courses show a

47% increase since 2005-2006. In addition, the respondents report that online learning is meeting the specific needs of a range of students, from those who need extra help and credit recovery to those who want to take Advanced Placement and college-level courses (Picciano & Seaman, 2009).

It should be noted that some of the above approaches were abandoned in the last decade in response to the political pressures of the No Child Left Behind (NCLB) movement. Some e-learning designers have expressed concern with the goals of the NCLB, claiming that they regress teaching and learning to more shallow learning outcomes.

## E-Learning Design in Europe

### How Educational Philosophies have Guided E-Learning Design in Europe

#### **General didactics.**

Before focusing on e-learning models, one should address the general didactics models and didactics itself, which has a long tradition in Europe in the context of education. This school of thought is having a strong influence on e-learning approaches, too. The very first time the concept was mentioned was 500, B.C.E., in ancient Greece. The word “didactics” is derived from the Greek word *didaskhein* and can be translated as “the art of teaching”, whereas the word *didaskaleion* (ca. 1127) means the location to show something (to someone).

A didactic model is a theoretical framework for the analysis and planning of didactic activities, actions, and interaction in institutionalized and non-institutionalized educational contexts. A didactical model is striving for the comprehensive enlightenment of the prerequisites, opportunities, and limitations of teaching and learning. A didactical model is often connected to one or several specific traditions in the philosophy of science (Jank & Meyer, 2010).

Central to didactics is the triangulation among the student, the teacher, and the content. Hence, it is called the didactic triangle (Figure 1). In most of the didactic approaches, specifically the newer ones, the reflective role of the teacher is central to the teaching process (Westbury, et al., 2000). The reflective activity requires that the teacher select, depict, and enrich the content (matter) of the given curriculum, for example, with the help of a didactical analysis (Klafki, 2002). The aim of a didactical analysis is to make the content meaningful to the learner. That is, the teacher is responsible for stressing topics that, from the teacher’s reflective perspective, will be essential to the students’ present and future lives. This is the so-called professional teacher’s liberty as it stresses the teacher’s duty to act in a self-reliant fashion. In a nutshell, the reflective teacher has

to make meaning out of the subject matter for the benefit of students' learning and development.

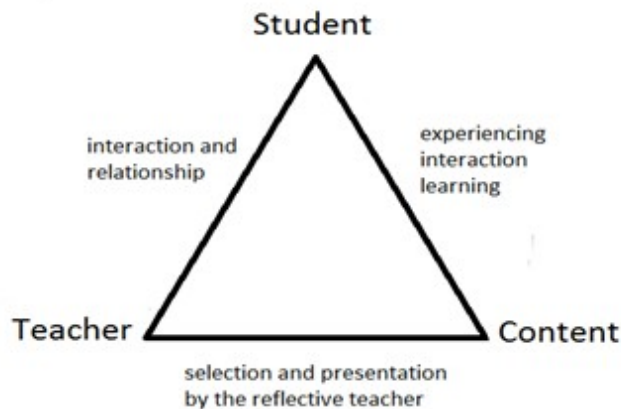

*Figure 1.* The didactic triangle.

There are over 13 different approaches (families) to didactics (Kron, 2008; Terhart, 2009; Kammerl, 2011) that can be subdivided into several models and concepts. Because of the emphasis on online teaching and learning in this paper, we will only address those approaches, models, and concepts that relate most directly to technology-based teaching and learning.

The use of information technology (IT) is considered more than just an additional or alternative teaching approach in education. Currently, IT is an integral part of most students' literacy: a meaningful element of their everyday life. Hence, it affects the matter of *Bildung* in a society (von Humboldt, 2000). The term *Bildung* is briefly translated as "formation" and is strongly related to the idea of didactics. Westbury et al. (2000) explain that this formation implies both the forming of the personality into a unity as well as the product of this formation and the particular "formedness" that is presented by the person. Thus, there is a need to critically reflect on how the opportunities and risks of using technology affect the overall development of the individual. The central question emerges as "What is the role of technology in teaching and learning?"

There are established models of general didactics, which include the use of technology as an integrated or framing element in teaching. An example is the Hamburg model, which is a normative, descriptive model. The Hamburg model, seen below (as translated by Gundem, 2011), takes into account students' need to be free to evaluate critically the influences of the system they are part of. It stresses media as a mediation variable named MV (see inner circle of the model, Figure 2), that is, technology as an auxiliary tool (MV mediation variable) for supporting or controlling the teaching and learning processes.

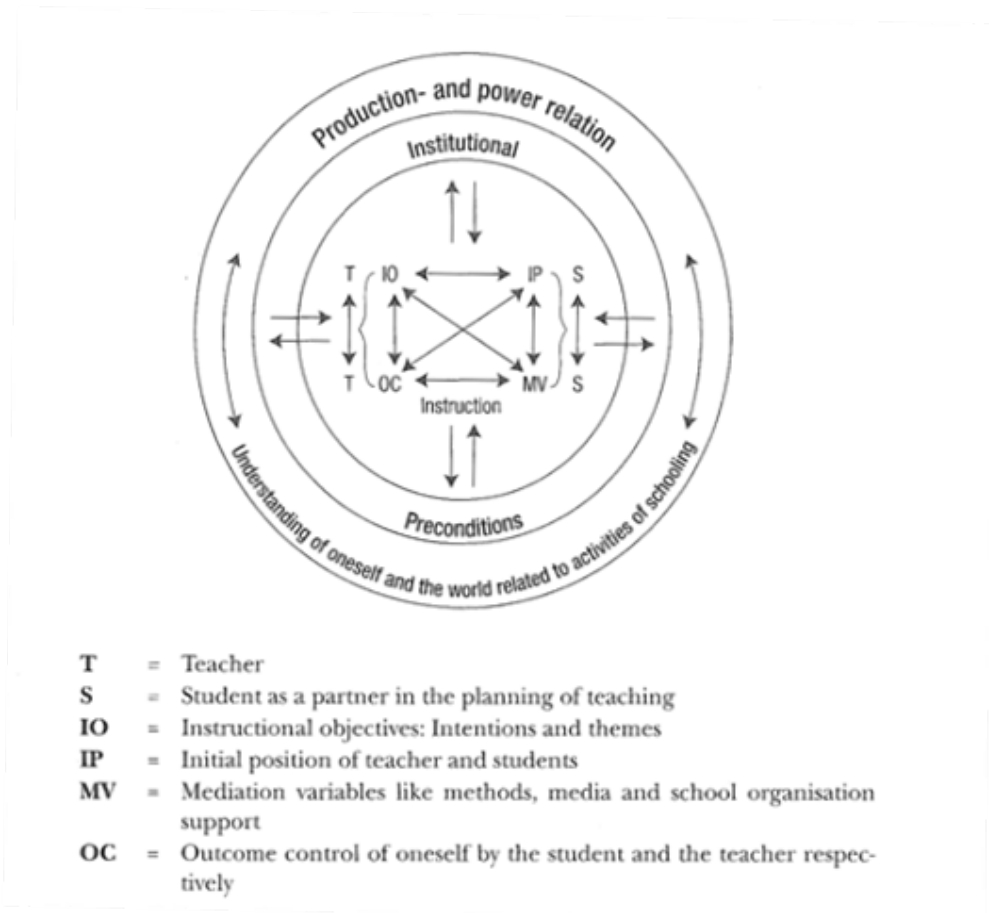

Figure 2. Hamburg model (Schulz, 1997; translated by Gundem, 2011).

The student (S) is seen as a partner in the planning of the instruction and the evaluation of the learning outcomes (OC). The model respects the institutional preconditions as well. The elements, methods, content, media, and intentions are seen as interrelated.

A related model in Norway is called 'relasjonsmodellen' (Bjørndal & Lieberg, 1978), which is used in adult education (Lodgaard, et al., 2001). Newer publications stress the meaning of the relational model as a framework for schooling (Østerud & Knudsen, 2009, p. 41) and criticize the missing support for objectives in teaching. The relational model asks the teacher to fill that gap. A general criticism of didactic approaches compared to instructional design approaches are that they do not respect enough the perspectives of the curriculum (Gundem, 2011) and the educational system. That is, didactic models are primarily designed from an individual's perspective (micro level) in teaching and learning. Other Scandinavian approaches to media didactics focus more on the subject-related application of media as a tool for teaching and learning (Iversen, et al., 2002).

## Specific Theories and Models Influencing E-Learning Design in Europe

### Media didactics.

In Europe, one can say that media didactics established its own discipline in the 1960s. The learning theory model of Heimann, Otto, and Schulz (1965) was one milestone followed by the later Hamburg model (Schulz, 1997). Media didactics can be described as a function and a consequence of applying media in teaching and learning processes (Issing, 1987, cited in Kron & Sofos, 2003, p. 48). An alternative classification by Tulodziecki and Herzig (2010, p. 110) describes media didactics as the relationship between instruction and the use of media. Hillen (Figure 3) depicts an overview of the different approaches to media didactics: teaching tool approach, learning tool approach, building block concept (elements), learning environment concept, and finally the systems concept, which is inspired by the approaches of programmed instruction. One perspective, of the systems approach, is based on the work of teams of instructional designers. The teachers themselves decide its usage. It is expected that students show a receptive and reactive learning behavior. Self-regulated learning is possible. The learning environment concept is primarily based on the idea of learning with learning management systems. Self-regulated and self-directed learning is expected and supported by the learning environment concept (Tulodziecki & Herzig, 2004, p. 112ff).

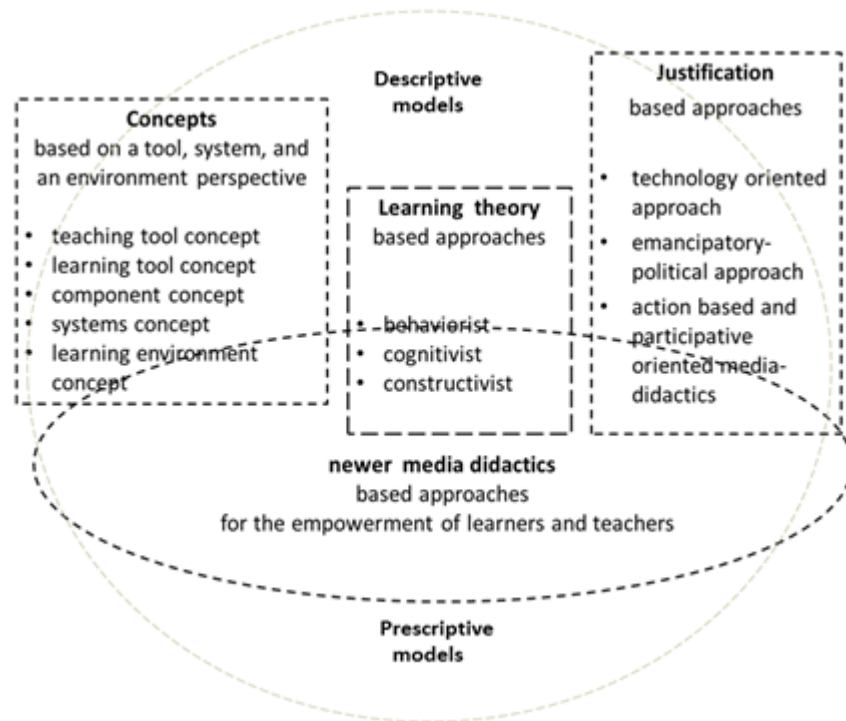

Figure 3. Approaches in media didactics (Hillen, 2013).



Another approach offers a classification of learning theories for media didactics orientation: behaviorist, cognitivist, and constructivist (Kron & Sofos, 2003, p. 54; Tulodziecki & Herzig, 2010, p. 128). The newer media didactics approaches are based on a constructivist paradigm, which calls for the proper use of media for the acquisition of knowledge in a meaningful way (Kron & Sofos, 2003). An additional approach was derived to offer justification for applying technology in educational and didactical contexts. The justification classification can be divided into a) technology oriented approach, b) emancipatory-political approach and, finally, c) the action based and participatory oriented media didactics (Kron & Sofos, 2003, p. 55).

Another European trend in media didactics is the so-called didactic design (Gissel, 2011, p. 17; Ballstaedt, 1997; Kerres, 2006). This has a strong affinity to the instructional design approach discussed above. One explanation is that media based learning needs explicit, advance planning for the application of media. Educators seek to prescribe the opportunities for interaction between the learner and the media, which has to be determined a priori (Kerres, 2006).

This tendency to construct planning oriented models for e-learning is common (see section below e.g., DO-ID) while neglecting the reflection of the (media-)didactics models. Media-didactic models inherently support paradigms for planning, conducting, and reflecting on Bildung. Despite newer developments, Tulodziecki (2005) criticizes the missing theoretical foundations in research and development in the context of media didactics. A statement from Haft (1988), even if it's over twenty years old, depicts the contrast between the two approaches: "Online-technology is speeding up but didactics is creeping slowly behind".

To summarize, media didactics comprises a variety of approaches that exist parallel to each other. Media didactics, its models and approaches, are influenced by general didactics, instructional design models, as well as by trends like didactic design that make the influences of instructional design models literally visible.

It has to be said that, because of the discussed trends above, one cannot generalize what the educational strategies in e-learning are. Instead, three general trends are chosen to reflect the diversity and breadth of strategies for e-learning and e-learning design one can find in Europe.

## E-Learning Design Arising from Innovative Instructional Strategies in Europe

### **Student empowerment – a descriptive model.**

As described above, new approaches in media didactics are working for the empowerment of learners and teachers (Tulodziecki & Herzig, 2004, 2010). Tulodziecki (2005) characterizes this as a transition from the use of technology as an auxiliary tool to that of complex learning environments (see Figure 2). The learning environment approach should support learners' interaction with complex tasks and problems. A



curriculum/educational initiative in Switzerland exemplifies the empowerment of students and teachers using information technology (IT). They name it the potential by teaching with information and communication technology (ICT). It focuses on skills like computer literacy as well as on media education (SFIB, 2007).

The theoretical framework for these powerful or rich learning environments is manifold. The well-known learning theories (behaviorist, cognitivist, and constructivist) are used as well as the didactical approaches named “action-based” (Jank & Meyer, 2010) and approaches that are participation-based (Kron & Sofos, 2003) are developed and applied as well (Tulodziecki, 2005).

In addition, the concept of situated learning appeared in the European educational landscape of learning environments (Mandl, et al., 2002) that was influenced, for example, by the Anglo-American cognitive flexibility theory, anchored instruction, and the cognitive apprenticeship approach (Straka & Macke, 2002).

### **Didactic design and the model of configuration-oriented media didactics – a prescriptive model.**

A prescriptive model of didactic design includes the development of an environment that supports learning from its conceptualizing phase until its evaluation. This constructivist oriented approach by Kerres (translated from Kerres “gestaltungsorientierte Mediendidaktik”, 2005, 2007) is seeking to use new, digital media to add value to classical forms of transfer and learning (Ballstaedt, 1997). The configuration-oriented media didactics model offers a framework, which justifies the use of new media even if more effort is needed. The following principles guide the model (Kerres & de Witt, 2004; Kerres, 2007, p. 173):

- A project always needs to address an educational and formative problem.
- The question is not to find and apply the ultimate best didactic method.
- An educational project has to be adjusted to the parameters of the didactic field, that is, the given situation (prerequisites).
- The specific media-configured learning approach must add value compared to other already existing solutions.

This framework is based on the opinion that the one ideal solution for media based teaching does not exist, but that a situational selection of the instructional means, for example media, is useful. The determining parameters are, for example, the media and method competencies of the teachers and students, the expectations of the people involved, societal trends, and so on (Kerres, 2005, 2007). Kerres’ approach follows the prescriptive idea for planning and conducting teaching with media. This assumes that specific learning results or learning events can be accomplished under different circumstances and conditions.

Applying this assumption one has to conclude that formation can be fabricated but this is orthogonal to the principles of a 'geisteswissenschaftliche' (humanistic) education, which states that Bildung (formation) cannot be created, configured, or induced. This is what makes the approach of Kerres inconsistent with the ideal of Bildung.

**The decision oriented instructional design model, Do-ID – a prescriptive model.**

The decision oriented instructional design model is an example of a model influenced by instructional design theory and project management approaches (see Figure 4). The decision-oriented instructional design model (Do-ID) seen below performs a prescriptive function. As in Niegemann et al. (2008, p. 85), this has the advantage of making contradictions in e-learning design visible as well as making general research gaps visible.

The Do-ID model can be described as a tool for systematic, project oriented planning for multimedia learning environments.

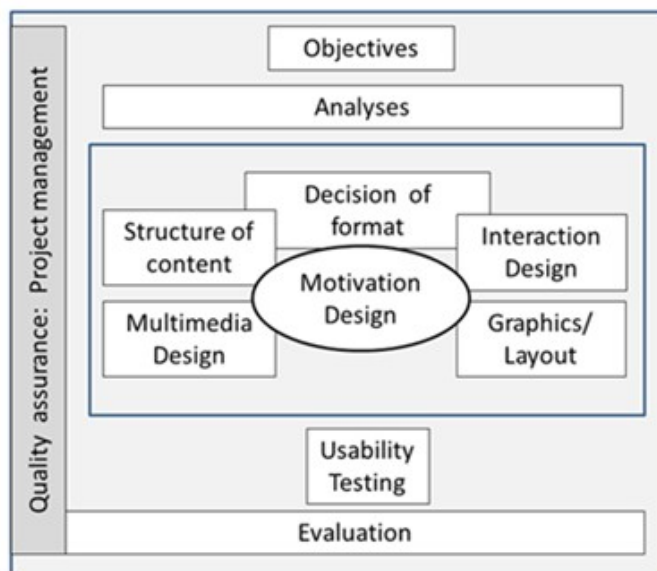

Figure 4. DO-ID model (in orientation to Niegemann, et al., 2008, p. 85).

The Do-ID model combines ideas of ID and project management to address concerns of quality management and evaluation. The model contains six decision components in which several design elements are to be addressed. These are the format, the structuring of the content, the selection and combination of media, the motivation of students, and the layout, the user interface with the software and hardware as well as respect for ethical constraints. The design decisions are interdependent.

The Do-ID model contributes to quality management by defining the objectives of the multimedia product. It also can be used for a critical reflection respecting its complexity within the whole.

Formats for e-learning design are expository, explorative, constructive, and the communicative e-learning system (Schübach, et al., 2003). The didactic structure reflects the learning theories used for the course.

## Analysis of the Two Educational Analyses

### Distinct Characteristics

It must be stressed that a comprehensive analysis over time is not in the scope of this paper, which nevertheless will not neglect the view of historical educational paradigms influencing the ongoing development of e-learning instruction.

#### **Roots, influences, and developments.**

The U.S. perspective started from a classical and instructional technology point of view (Oakes & Lipton, 1999), whereas the European is derived from a didactics and later a media-didactics perspective (Klafki, 2002; Schulz, 1997). While both approaches share some ground related to the educational philosophies, the Norwegian report goes more deeply into the abstract notion of *Bildung*, an intense valuing of the formation of the individual. While American theorists are devoted to the importance of personal learning programs, their arguments appear to lack ardor when compared to the European shared value of *Bildung*.

The U.S. analysis shows some of the newest approaches as advocating a more severe departure from existing learning theory. Advocates of chaos theory tenets and major shifts to accommodate the digital generation call for techniques using simulation in virtual worlds to gaming. Newer approaches in the European analysis appear to retain a relationship with traditional theories from the didactics and *Bildung* traditions even if some liberties are taken with prescriptive and ID models. Even quite different prescriptive and descriptive models, however, are trending toward similar objectives: the empowerment of the learner applying media for learning purposes.

### Affinities Between the Analyses of Both Regions

#### **Learning theories, methods, and the learners' growth.**

Both regions acknowledge the power of behaviorism, cognitivism, and constructivism as guiding principles with constructivism moving to the fore in many recent models. The concepts of active (Howland, et al., 2011) or participant-based learning (Kron & Sofos,

2003) are currently stressed in both arenas. Even as the instructional design models have become more diverse in both countries, the underlying paradigms have undergone changes from design of strongly behavioristic oriented programs (e.g., drill and practice) to cognitivist and constructivist oriented ones. Both describe an affinity for more authentic, situation-based learning.

It is apparent that European and American traditions have influenced each other. The analyses show that specific U.S. e-learning design theories presented have become a meaningful part in rich or complex learning environments in Europe. Likewise, the record of Europe's open learning experience has provided a legacy for newer American distance learning programs.

Both analyses describe planning and reflecting approaches which seek to consider the many complexities of a given learning environment prior to delivery of instruction. Though both traditions have struggled between prescriptive and descriptive models, over time both have opened up to the importance of the empowerment of learners and teachers. Careful analysis and flexibility are encouraged to better insure quality management and to maximize the learner's growth.

#### **Acknowledgement of the challenges and potentials for e-learning.**

Both analyses recognize the potential and the challenges inherent in e-learning. They work to respond to research results from other disciplines (e.g., direct teaching, rapid prototyping, chaos theory, project management) to improve the development and implementation of e-learning. Several emerging trends in e-learning, such as the globalization of distance education, the availability of informal learning opportunities, the ubiquity of cyberspace connections around the world, and the presence of technology in everyday life and learning have unleashed the control of e-learning design from professional instructional designers. With or without them, learners are gaining access to all forms of information and learning experiences in an unstructured, personalized fashion. It has become the task of designers to deal with learners with wildly different entry skills and learning needs. Modern online capacities have challenged e-learning designers to develop drastically new learning-teaching strategies such as communities of learners, gaming, artificial intelligence, and global collaboration. Happily, both continents are simultaneously seeing the importance of providing communication between the students and others (Johnson & Johnson, 1994; Fogarty, 1999, p. 76; Schüpbach, 2003).

#### **'Multi-theory' approach.**

Both traditions have started to acknowledge that a 'multi-theory' approach serves better the needs of learners and teachers than striving after a single best e-learning design approach or single e-learning theory. Approaches exist in parallel – choose the best.

## Conclusions and Outlook

This overview of e-learning design on the two continents has tried to capture the broad patterns of the two regions and educational traditions. While both reports acknowledge common guiding educational philosophies (behaviorism, cognitivism, and constructivism), differing political pressures and values have influenced the progression of e-learning design approaches in each region. Recent e-learning design in the United States appears to have been guided by goals related to learners' competencies in basic skills and professional readiness. Europe appears to have retained a central allegiance to the development for the whole individual (*Bildung*).

These statements are over-generalizations, of course. We acknowledge that there are strong movements on each continent that swim against the current. For example, there is evidence that Europe is now moving to standardize competencies (similar to the NCLB movement in America) and the U.S. is rediscovering the importance of skills beyond testable competencies. Perhaps this paradox is worth noting. One continent may be at odds with the other at a given time but, interestingly, the swings of the pendulum appear ultimately responsive to each other.

There are trends common to both regions that are worth discussion. Both reports note that in early e-learning planning technology was used as a relatively minor tool to support existing teaching and learning processes used to master content goals. As testing became more dominant in the U.S., exposing the weaknesses of existing instructional design, and as the power of the Internet to free the learner to pursue individual curiosities and learning paths became undeniable, instructional designing began to shift from more prescriptive modes of e-learning design to more spontaneous, collaborative, and action-based learning.

The wave of online learning swept over from higher education to secondary and primary education in both continents. In the U.S., this trend is visible in public and in private education as well. This applies for European education too, whereas in European education systems this differentiation has not played a very important role in the past (Debande, 2004). This is due to the fact that in most of the European educational systems public schools were predominant. This is based on the idea of free access to schools and on the idea of 'Bildung for all', even though a change can be observed by the arrival of the 'accountability concept' in the public sectors in Europe.

On both continents, e-learning models have emerged which acknowledge the power of technology to fundamentally change how and what learning takes place. These models seem to adopt a multi-theory approach to design. What's more, these models identify expanded goals and competencies resulting from modern societal demands and the unbridled opportunities offered by the Web. Many new media design models include the provision of an online infrastructure that provides content information, multiple resources, collaborative opportunities, and sometimes even alternate paths for achieving objectives. What's more, the re-commitment to more critical thinking and

problem solving is manifest in the refinement of situational learning approaches (problem-based learning, case studies, simulations, etc.).

In most programs, the role of the e-learning designer or e-teacher is increasingly complex. Providing a balance between identifying clear central objectives and designing activities that are open enough to respond to autonomous learning needs is a tricky prospect. Yet, it appears to be the only choice if we are to embrace the remarkable potential of electronic access to unlimited data and expertise. One can recognize a trend toward a higher level of customized learning (personalization, individualization, contextualization, and adaptive learning). Student involvement is often required throughout to promote autonomy and transfer. Collaboration and communication are no longer centered on the teacher and e-learning design must acknowledge this. It is obvious that e-learners can now pursue their own paths with or without the instructor and the challenge is for the design to allow for a variety of learning paths for the benefit of individual learners.

Thus, we can assume that the e-learning landscape will become even more diverse. Some learners are not ready for learning environments where they are asked to take charge of their own growth. Some professions and disciplines rely on the mastery of critical content and competencies. Thus, there will continue to be prescriptive, content-centered design needs in the e-learning environment. Still, we must recognize the importance of newer forms of e-learning design and their potential to meet essential human and societal needs.

The identification of a historical framework has helped the researchers to reflect on how e-learning design has developed over recent decades and how newer approaches have emerged in both regions. It is hoped that the observance of common emerging trends has contributed to a better understanding of the broad scope of e-learning design. Recognizing the parallelism of newer multi-theory design options undergirded by shared educational philosophies but differing cultural ethics may help designers to operate in our newly global design environment. More importantly, it is hoped that increased awareness of newer modes of design might help to avoid limiting design options to simplistic, prescriptive patterns that have, in the past, limited opportunities for ever-expanding learners' and teachers' needs.

## References

- Baker, S. C., Wentz, R. K., & Woods, M. M. (2009). Using virtual worlds in education: Second Life as an educational tool. *Teaching of Psychology, 36*(1), 59-64.  
Retrieved from <http://edtc6325teamone2ndlife.pbworks.com/f/VitruaWorldsSLI+.pdf>
- Ballstaedt, S. P. (1997). Wissensvermittlung. Die Gestaltung von Lernmaterial [Transfer of knowledge. The creation of learning material; in German]. Weinheim: Beltz Psychologie Verlags Union.
- Baylor, A. L., & Kim, Y. (2005). Simulating instructional roles through pedagogical agents. *International Journal of Artificial Intelligence in Education, 15*(1), 95-115.
- Bjørndal, B., & Lieberg, S. (1978). Nye veier i didaktikken?: en innføring i didaktiske emner og begreper [New ways towards didactics?: an introduction in topics and concepts of didactics; in Norwegian]. Oslo: Aschehoug.
- Brown, A. L., & Campione, J.C. (1994). Guided discovery in a community of learners. In K. McGilly (Ed.), *Classroom lessons: Integrating cognitive theory and classroom practice* (pp. 229-270). Cambridge, MA: MIT Press/Bradford Books.
- Brown, J. S., Collins, A., & Duguid, P. (1989). Situated cognition and the culture of learning. *Educational Researcher, 18*(1), 32-41.
- Carlén, U., & Jobring, O. (2005). The rationale of online learning communities. *International Journal of Web Based Communities, 1*(3), 272-295.
- Charalambos, V., Michalinos, Z., & Chamberlain, R. (2004). The design of online learning communities: Critical issues. *Educational Media International, 41*(2), 135-143.
- Clark, R., & Mayer, R. (2011). *E-learning and the science of instruction: Proven guidelines for consumers and designers of multimedia learning*. New York: Pfeiffer.
- Cognition and Technology Group at Vanderbilt (1990). Anchored instruction and its relationship to situated cognition. *Educational Researcher, 19*(6), 2-10.
- Cognition and Technology Group at Vanderbilt (1991). Technology and the design of generative learning environments. *Educational Technology Journal, 31*(5), 34-40.
- Cognition and Technology Group at Vanderbilt (NA). Cognitive flexibility theory.  
Retrieved from [http://otec.uoregon.edu/learning\\_theory.htm](http://otec.uoregon.edu/learning_theory.htm)



- Cohen, A. M. (2011). The gamification of education. *The Futurist*, 45(5), 16-17. Retrieved from <http://search.proquest.com/library.sheridanc.on.ca/docview/884627174?accountid=3455>
- Creative Industries Research Institute (2007). *Introduction to rapid prototyping*. AUT University. Retrieved from <http://www.ici.qut.edu.au/researchdomains/designfuture.jsp>
- Culatta, R. (2011). *Rapid prototyping*. Instructional Design.org. Retrieved from [http://www.instructionaldesign.org/models/rapid\\_prototyping.html](http://www.instructionaldesign.org/models/rapid_prototyping.html)
- Debande, O. (2004). Icts and the development of elearning in europe: The role of the public and private sectors. *European Journal of Education*, 39(2), 1465-3435. <http://dx.doi.org/10.1111/j.1465-3435.2004.00175.x>
- Deterding, S. (2013). Gameful design for learning. *T+D*, 67(7), 60-63.
- de Vries, E. (2003). Educational technology and multimedia from a cognitive perspective: Knowledge from inside the computer, onto the screen and into our heads? In H. van Oostendorp (Ed.), *Cognition in a digital world* (pp. 155-174). Mahwah, NJ: Lawrence Erlbaum Associates
- Dick, W.O., Carey, L., & Carey, J. O. (2004). *Systematic design of instruction*. Boston, MA: Allyn & Bacon.
- Ellis, A. K., & Fouts, J. T. (1997). *Research on educational innovations* (2<sup>nd</sup> ed.). Princeton Junction, N.J.: Eye on Education.
- Fogarty, R. (1999). Architects of the intellect. *Educational Leadership*, 57(3), 76-78.
- Gissel, S. T. (2011). *Mediedidaktik i teori og praksis* [Media didactics: theory and practice, in Danish]. København: Academia Forlag.
- Gollub, J., & Solomon, T. (1996). Chaos theory. In K. A. Ranson (Ed.), *Academic American encyclopedia* (V. 4, pp. 282- 283). Danbury, CT: Grolier Incorporated.
- Gundem, B. B. (2011). *Europeisk Didaktikk. Tenkning og viten* [European didactics. Thinking and knowledge; in Norwegian]. Oslo: Universitetsforlaget.
- Gustafson, K. L., & Branch, R. M. (1997). *Survey of instructional development models* (3<sup>rd</sup> ed.). Syracuse, NY: ERIC Clearinghouse of Information and Technology.
- Gustafson, K. L., & Branch, R. M. (2002). What is instructional design? In R. A. Reiser & J. V. Dempsey (Eds.), *Trends and issues in instructional design and technology* (pp. 16-25). Columbus: OH, Merrill Prentice Hall.



- Haft, H. (1988). Einführung: "Neue Medien und Sozialisation - Die Technik rennt, die Forschung humpelt [Technology is running, research is hobbling]. *Unterrichtswissenschaft*, 16(4), 2-6.
- Heimann, P., Otto, G., & Schulz, W. (1965). Unterricht-Analyse und Planung [Teaching, analysis and planning]. Hannover: Schroedel.
- Hillen, S. (2013). What can research in technology and learning teach media didactics? In K. Beck & O. Zlatkin-Troitschanskaia, (Eds.), *From diagnostics to learning success. Proceedings in vocational education and training* (pp. 101-113). Rotterdam: Sense.
- Hokanson, B., & Miller, C. (2009). Role-based design: A contemporary framework for innovation and creativity in instructional design. *Educational Technology*, 49(2), 21-28.
- Howland, J., Jonassen, D.H., & Marra, R.M. (2011). *Meaningful learning with technology* (4<sup>th</sup> ed.). Columbus, OH: Merrill/Prentice-Hall.
- Issing, L. (Ed) (1987). Medienpädagogik im Informationszeitalter [Media education in the information age; in German]. Weinheim. Deutscher Studienverlag.
- Iversen, G. B., Asmussen, J., Carlsen, B. B., & Nelson, C. (2002). Mediedidaktik [Media didactics; in Danish]. Frederiksberg: Dansklærerforeningen Forlag.
- Jank, W., & Meyer, H. (2010). Didaktiske Modeller [Didactic models; in Danish]. København: Gyldendal.
- Johnson, D., & Johnson, R. T. (1988). *Cooperative learning. Transforming education*. Context Institute. Retrieved from <http://www.context.org/iclib/ic18/>
- Johnson, D. W., & Johnson, R. T. (1994). *Cooperative, competitive, and individualistic learning* (4th ed.). Needham Heights, MA: Allyn and Bacon.
- Jonassen, D. H. (2000). Toward a design theory of problem-solving. *Educational Technology Research and Development*, 48(4), 63-85.
- Jonassen, D. H. (2006). On the role of concepts in learning and instructional design. *Educational Technology Research & Development*, 54(2), 177-196.
- Jonassen, D. H. (2011). *Learning to solve problems: A handbook for designing problem-solving learning environments*. New York: Routledge.
- Jonassen, D. H., Carr, C., & Yueh, H. (2007). Computers as mindtools for engaging learners in critical thinking. *TechTrends*, 43(2), 24-32.

- Jones, B., Valdez, G., Nowakowski, J., & Rasmussen, C. (1994). *Designing learning and technology for educational reform*. Oak Brook, IL: North Central Regional Educational Laboratory.
- Kammerl, R. (2011). Media, Bildungstheorie and Didactics. In S.Hillen, T. Sturm & I. Willbergh (Eds.). *Challenges facing contemporary didactics: Diversity of students and the role of new media in teaching and learning* (pp. 129-142). Münster: Waxmann.
- Kerres, M. (2005). Gestaltungsorientierte Mediendidaktik und ihr Verhältnis zur Allgemeinen Didaktik [Configuration oriented media didactics and its relationship to general didactics, in German]. In P. Stadtfeld, & B. Dieckmann (Eds.), *Allgemeine Didaktik im Wandel* (pp. 214-234). Heilbrunn: Klinkhardt Verlag.
- Kerres, M. (2006). Didaktisches Design und E-Learning [Didactic design and E-Learning; in German] (pp. 156-182). In D. Miller (Ed.), *eLearning. Eine multiperspektivische Standortbestimmung*. Bern: Hauptverlag.
- Kerres, M. (2007). Zum Selbstverständnis der Mediendidaktik—eine Gestaltungsdisziplin innerhalb der Medienpädagogik [The self conception of media didactics - a discipline within media education; in German]? In W. Sesink, M. Kerres, & H. Moser (Eds.), *Jahrbuch Medien-Pädagogik 6*. (pp. 161-178). Wiesbaden: VS Verlag für Sozialwissenschaften.
- Kerres, M., & de Witt, C. (2004). Pragmatismus als theoretische Grundlage für die Konzeption von e-learning [Pragmatism as theoretical platform for the conception of e-learning; in German]. In H. O. Meyer, & D. Treichel (Eds.), *Handlungsorientiertes Lernen und eLearning* (pp. 77-99). München: Oldenburg.
- Klafki, W. (2002). Characteristics of critical-constructive didaktik. In B. B. Gündem & S. Hopmann (Eds.), *Didaktik and /or curriculum. an international dialogue* (pp. 307-330). Frankfurt: Peter Lang.
- Kron, F. W. (2008). *Grundwissen der Didaktik* [Basic principles in didactics; in German]. (5th ed.). München, Basel: Reinhardt.
- Kron, F. W., & Sofos, A. (2003). *Mediendidaktik. Neue Medien in Lehr- und Lernprozessen* [Media didactics. New Media in teaching and learning processes; in German]. München: Ernst Reinhardt.
- Lave, J., & Wenger, E. (1991). *Situated learning: Legitimate peripheral participation*. Cambridge: Cambridge University Press.

- Lodgaard, E., Melbye, P. E., Torgersen, G.-E., & Loeng, S. (2001). *Voksenpedagogikk i kompetansesamfunnet* [Adult education in a competence society; in Norwegian]. Skarnes: Compendius.
- Lorenzen, M. (2008). Chaos theory and education. The information literacy land of confusion. Retrieved from <http://www.information-literacy.net/2008/04/chaos-theory-and-education.html>
- Mandl, H., Gruber, H., & Renkl, A. (2002). Situiertes Lernen in multimedialen Lernumgebungen [Situating learning in multimedia learning environments; in German]. In L. J. Issing & P. Klimsa (Eds.), *Information und Lernen mit Multimedia und Internet* (pp. 139–148). (2nd ed.). Weinheim: Beltz Psychologie Verlags Union.
- Mayer, R., & Moreno, R. (1998). Split-attention effect in multimedia learning: Evidence for dual processing systems in working memory. *Journal of Educational Psychology, 90*(2), 312-320.
- McLeod, S. (2008). Information processing. *Simply Psychology*. Retrieved from <http://www.simplypsychology.org/information-processing.html>
- Morrison, G., Ross, S., & Kemp, J. (2004). *Designing effective instruction*. Hoboken, NJ: John Wiley & Sons, Inc.
- Niegemann, H. M., Domagk, S., Hessel, S., Hein, A., Hupfer, M., & Zobel, A. (2008). *Kompodium multimodales Lernen* [Compendia multimodal learning; in German]. Berlin: Springer.
- Nipper, K. (ND). *Curriculum development project: The adventures of Jasper Woodbury series*. University of Georgia. Retrieved from <http://jwilson.coe.uga.edu/emt668/EMT668.Folders.F97/Nipper/EMAT6690/Jasper/Jasper.html>
- Oakes, J., & Lipton, M. (1999). *Teaching to change the world*. Boston: McGraw-Hill College.
- Østerud, S., & Knudsen, M. (2009). Rom og tid i didaktiske modeller [Space and time in didactics models; in Norwegian]. In S. Østerud (Ed.), *Enter veien mot en IKT-didaktikk*. Oslo: Gyldendal Akademisk.
- Paloff, R. M., & Pratt, K. (2007). *Building online learning communities – effective strategies for the virtual classroom*. San Francisco, CA: Wiley.
- Picciano, A. G., & Seaman, J. (2007). K–12 online learning. Survey of U.S. school district administrators. Retrieved from [http://sloanconsortium.org/publications/survey/K-12\\_06](http://sloanconsortium.org/publications/survey/K-12_06)

- Picciano, A. G., & Seaman, J. (2009). K–12 online learning. A 2008 follow-up of the survey of U.S. school district administrators. Retrieved from <http://www.onlinelearningsurvey.com/reports/k-12-online-learning.pdf>
- Piskurich, G. M. (2006). *Rapid instructional design: Learning ID fast and right*. San Francisco, CA: John Wiley and Sons.
- Prensky, M. (2001). *Digital game-based learning*. New York: McGraw-Hill.
- Reigeluth, C. M. (Ed.) (1987). *Instructional theories in action. Lessons illustrating selected theories and models*. London: Lawrence Erlbaum Associates.
- Reigeluth, C. M. (1999). The elaboration theory: Guidance for scope and sequence decisions. In C.M. Reigeluth (Ed.), *Instructional-design theories and models: A new paradigm of instructional theory* (Volume II, pp. 425-454). Hillsdale, NJ: Lawrence Erlbaum Assoc.
- Rowland, G. (1992). What do instructional designers actually do? An initial investigation of expert practice. *Performance Improvement Quarterly*, 5(2), 65-86.
- Schank, R. (1997). *Virtual learning: A revolutionary approach to building a highly skilled workforce*. New York: McGraw-Hill.
- Schneider, W., & Shiffrin, R. M. (1977). Controlled and automatic human information processing: 1. Detection, search, and attention. *Psychological Review*, 84, 1-66.
- Schüpbach, E., Guggenbühl, U., Krehl, C., Siegenthaler, H., & Kaufmann-Hayoz, R. (2003). Didaktischer Leitfaden für E-Learning [Didactic code of practice for e-learning; in German]. Bern: h.e.p.-Verlag.
- Schulz, W. (1997). Die lehrtheoretische Didaktik [Learning theoretical didactics; in German]. In H. Gudjons (Ed.), *Didaktische Theorien* (pp. 35-56). Hamburg: Winkelverlag.
- Seminole County Public Schools (2014). Retrieved from <http://www.scps.k12.fl.us/Home.aspx>
- SFIB (2007). Educaguides. Guides zur Beratung und Unterstützung von Lehrpersonen, Ausbilderinnen und Ausbildern beim Einsatz von ICT im Unterricht. Schweizerische Fachstelle für Informationstechnologien im Bildungswesen. Retrieved from [http://guides.educa.ch/sites/default/files/Didaktik\\_d\\_kurz.pdf](http://guides.educa.ch/sites/default/files/Didaktik_d_kurz.pdf)
- Smith, P. L., & Ragan, T. J. (1999). *Instructional design* (2<sup>nd</sup> ed.). New York: Merrill, Macmillan Publishing Company.

- Squire, K., Johnson, C., & Bichelmeyer, B.A. (1998). Personalized independent learning systems in high technology environments. *Proceedings of selected research and development presentations at the 1998 National Convention of the Association for Educational Communications and Technology*. St. Louis, MO, USA. (ERIC Document Reproduction Service No. ED423873).
- Straka, G. A., & Macke, G. (2002). Lern-lehrtheoretische Didaktik [Learning-teaching theoretical didactics; in German]. Münster: Waxmann.
- Sweller, J. (1999). *Instructional design in technical areas*. Camberwell, Victoria, Australia: Australian Council for Educational Research.
- Terhart, E. (2009). Didaktik. Eine Einführung [Didactics. An introduction; in German]. Stuttgart: Reclam.
- Thomas, D., & Brown, J. S. (2011). *Createspace, quest to learn. A new culture of learning*. Retrieved from [www.Q2L.org](http://www.Q2L.org)
- Tulodziecki, G. (2005). Zur Situation der Medienpädagogik in der Bundesrepublik Deutschland [About the situation of media education in the German Federal Republic]. Retrieved from <http://www.medienpaed.com/Documents/medienpaed/11/tulodziecki05-1.pdf>
- Tulodziecki, G., & Herzig, B. (2010). Mediendidaktik. Medienverwendung in Lehr- und Lernprozessen [The use of media in teaching and learning]. München: kopäd.
- Tulodziecki, G., & Herzig, B. (2004). Handbuch Medienpädagogik. Band 2: Mediendidaktik. Medien in Lehr- und Lernprozessen [Handbook of Media education]. Volume 2: Media didactics. Media in teaching and learning processes; in German]. Stuttgart: Klett Cotta.
- von Humboldt, W. (2000). Theory of Bildung. In I. Westbury, K. Riquarts & S. Hopmann (Eds.), *Teaching as a reflective practice: The German didaktik tradition* (pp. 57-61). Mahwah, N.J.: Lawrence Erlbaum Associates.
- Westbury, I., Riquarts, K., & Hopmann, S. (2000). *Teaching as a reflective practice: The German didaktik tradition*. Mahwah, N.J.: Lawrence Erlbaum Associates.

Athabasca University 



## Towards Development of OER Derived Custom-Built Open Textbooks: A Baseline Survey of University Teachers at the University of the South Pacific



Deepak Prasad and Tsuyoshi Usagawa  
Kumamoto University, Japan

### Abstract

Textbook prices have soared over the years, with several studies revealing many university students are finding it difficult to afford textbooks. Fortunately, two innovations – open educational resources (OER) and open textbooks – hold the potential to increase textbook affordability. Experts, though, have stated the obvious: that students can save money through open textbooks only if teachers are willing to develop and use them. Considering both the high price of textbooks and the benefits offered by OER and open textbooks, the aim of this study was to assess the University of the South Pacific (USP) teachers' willingness towards development of custom-built OER derived open textbooks for their courses with a focus on providing a foundation for strategies to promote open textbook development at USP. This paper reports the findings of an online survey of 39 USP teachers. The results show that 17 teachers were willing to develop OER derived custom-built open textbooks for their courses. Besides this, there are findings relating to six important areas: teachers' motivation to develop open textbooks; the frequency of more than one prescribed textbook per course; teachers' awareness of the costs of the prescribed textbooks; the average cost of prescribed textbooks in a course; teachers' awareness and utilization of OER and open textbooks; and teachers' perceived barriers to using OER and types of challenges they encounter while using OER. These findings have been discussed in relation to research studies on OER and open textbooks.

**Keywords:** Open educational resources; open textbooks; willingness; awareness; barriers; motivators; University of the South Pacific

## Introduction

Textbook prices have clearly spiralled upward in recent years; between 1978 and 2012 textbook costs in the United States of America have risen an alarming 812% (Perry, 2012). Hallam (2012) pointed out that the textbook industry thrives on the notion of 'prescribed textbooks,' with more students purchasing textbooks when told to do so by their teacher. In a study conducted in the United Kingdom, 83% of students purchased textbooks when prescribed by the teacher, compared with 30% who purchased textbooks simply due to recommendation (Carpenter, Bullock, & Potter, 2006). Sadly, it is not uncommon to see teachers prescribe multiple textbooks when they cannot find a single textbook that meets the learning objectives of their course (Wiley, Green, & Soares, 2012).

Several studies have revealed the difficulty university students face in affording textbooks. In a 2011 survey of 1,905 undergraduate students, 70% of students reported not purchasing at least one prescribed textbook due to cost, despite 78% believing they would do worse in the course without their own copy of the prescribed text (Allen, 2011). Similarly, according to a 2013 survey of 2,039 students from more than 150 different university campuses, 65% of students indicated they had decided against buying a textbook because it was too expensive, 48% said the cost of textbooks had an impact on how many or which classes they took, and 94% of the students who had avoided buying a prescribed textbook said they were concerned that doing so would negatively affect their grade in that course (Senack, 2014). These surveys indicate that when students do not have their own copy of the prescribed textbooks, they lag behind, compromise their learning outcomes, and increase their chances of failing their course (Acker, 2011; Allen, 2011; Graydon, Urbach-Buholz, & Kohen, 2011; Morris-Babb & Henderson, 2012; Senack, 2014). The above discussion illustrates that the high cost of textbooks has a cumulative adverse impact on higher education that requires a solution.

Fortunately, an innovation known as open textbooks holds the potential to increase textbook affordability (Hilton & Wiley, 2011; Okamoto, 2013). Essentially, "Open textbooks are similar to traditional textbooks in terms of content; however, they are generally available for free in digital format, along with low-cost print copies" (Hilton, Gaudet, Clark, Robinson, & Wiley, 2013, p. 38). Several open textbooks initiatives have emerged lately, promising to address the problem of textbook affordability for students. In a survey of open textbook adoption in three high school science courses, Wiley, Hilton, Ellington, and Hall (2012) report that open textbooks cost over 50% less than traditional textbooks without loss of quality of learning outcomes as measured by standardized tests. In the area of higher education, Bliss, Hilton, Wiley, and Thanos (2013), in a survey of over 125 students and 11 teachers from seven colleges, found that the majority of students and teachers were satisfied using open textbooks, valued the cost savings, and acknowledged the texts as being of high quality. These findings were supported in the results of a recently published survey: Senack (2014) reported that 82% of students said free online access to a textbook (with the option of buying a hard



copy) would help them do “significantly better” in a course. Senack argues for widespread use of open textbooks, which he estimates can save students an average of \$100 per course.

Open textbooks are basically a subset of open educational resources (OER) (Hilton et al., 2013). The past several years have seen an exponential increase in the creation and use of OER, which, according to an often-cited definition, are

teaching, learning, and research resources that reside in the public domain or have been released under an intellectual property license that permits their free use and re-purposing by others. Open educational resources include full courses, course materials, modules, textbooks, streaming videos, tests, software, and any other tools, materials, or techniques used to support access to knowledge. (Atkins, Brown, & Hammond, 2007, p. 4)

Experts have recommended that teachers develop OER based custom-built open textbooks that meet their course needs instead of prescribing multiple proprietary textbooks (Bliss et al., 2013; Senack, 2014; Wiley, Green, et al., 2012). The OER based approach to open textbook development has three important benefits: Textbooks can be built upon existing OER rather than developing from scratch; because OER can be edited or abandoned at less cost than commercial adoption, teachers risk less when developing with vetted OER materials (Acker, 2011); and OER reduces the time lag between the development of textbooks and their delivery, and enables reuse, recontextualization, and customization to meet the course learning outcomes (Baraniuk, 2013).

Despite the diversity and obvious benefits of OER, the University of the South Pacific (USP) has yet to take full advantage of such open resources. USP is located in the hub of the Pacific Ocean; it is one of only two regional universities in the world, with over 27,000 students. The University is jointly owned by 12 member countries: Cook Islands, Fiji, Kiribati, Marshall Islands, Nauru, Niue, Samoa, Solomon Islands, Tokelau, Tonga, Tuvalu and Vanuatu. The academic schools, institutes and centres at the USP are organized into three faculties: the Faculty of Arts, Law and Education (FALE); the Faculty of Business and Economics (FBE); and the Faculty of Science, Technology and Environment (FSTE).

Amazingly, as an increasing number of higher education institutions around the globe are developing and offering open textbooks in an effort to increase their affordability, most USP teachers continue to prescribe traditional published textbooks to their students who find it difficult to afford. Bliss et al. (2013) state that students can save money with open textbooks only if teachers are willing to develop them. This



background raises the question of whether USP teachers are willing to develop open textbooks for their courses. While there is no clear answer at present, there is anecdotal evidence of use of OER based learning resources and activities in some courses. It is, therefore, important to go beyond anecdotes in order to strategize possibilities for future development of OER derived custom-built open textbooks at USP. Hence, this study aims to assess USP teachers' willingness towards development of custom-built OER derived open textbooks for their courses. This aim further focused on the following specific objectives:

1. To determine the status of four areas when textbooks are prescribed: frequency with which teachers prescribe textbooks; frequency of more than one prescribed textbook per course; teachers' awareness of textbook prices before prescription; and average cost of prescribed textbooks per course.
2. To investigate teachers' awareness and utilization of OER and open textbooks.
3. To identify teachers' perceived barriers to using OER and types of challenges they encounter while using OER.
4. To identify teachers' motivators to develop OER derived custom-built open textbooks for their courses.
5. To identify teachers willing to collaborate with the primary author to develop OER derived custom-built open textbooks for their courses.

## Method

In pursuit of the above objectives, the overall strategy was to survey USP teachers using a self-administered online questionnaire partly developed for this study and partly making use of questions from *2012 Faculty and Administrator Open Educational Resources Survey* (Florida Virtual Campus, 2012).

## Theoretical Perspective

Open textbooks and OER are a fairly new phenomenon at the USP. A descriptive study is adequate where the research area is relatively new or unexplored (Punch, 2005). Thus, this study adopted the descriptive (survey) study. As a descriptive study, no specific conceptual framework or theory was applied. According to Koul (2009), descriptive studies

constitute a primitive type of research and do not aspire to develop an organized body of scientific laws. Such studies, however, provide information useful to the solution of local problems and at times provide data to

form the basis of research of a more fundamental nature.  
(p. 104)

This descriptive study thus sought to simply find out what the present situation is, with regard to open textbooks and OER, from the teacher perspective at the USP.

## Survey Questionnaire

The first draft questionnaire was content validated by two international experts. Based on their comments, the final version of the questionnaire was drawn up, and was tried out/piloted on five USP teachers. From the feedback of the trial, expressions for two items were modified. The final questionnaire included 20 items divided into four sections: demographics, prescribed textbooks status, awareness and utilization of OER and open textbooks, and willingness towards OER derived custom-built open textbooks development. Figure 1 illustrates the questionnaire design. The questionnaire included skip logic or routing questions. Skip logic “refers to a respondent taking an alternative path through a questionnaire depending on his or her answer to an earlier question” (Schonlau, Fricker, & Elliott, 2002, p. 30). For example, as illustrated in Figure 1, a ‘no’ response to question 10, indicating that the respondent is not aware of OER, prompts the respondent to skip to question 15, past the questions related to OER understanding and usage. The questionnaire comprised both closed- and open-ended questions.

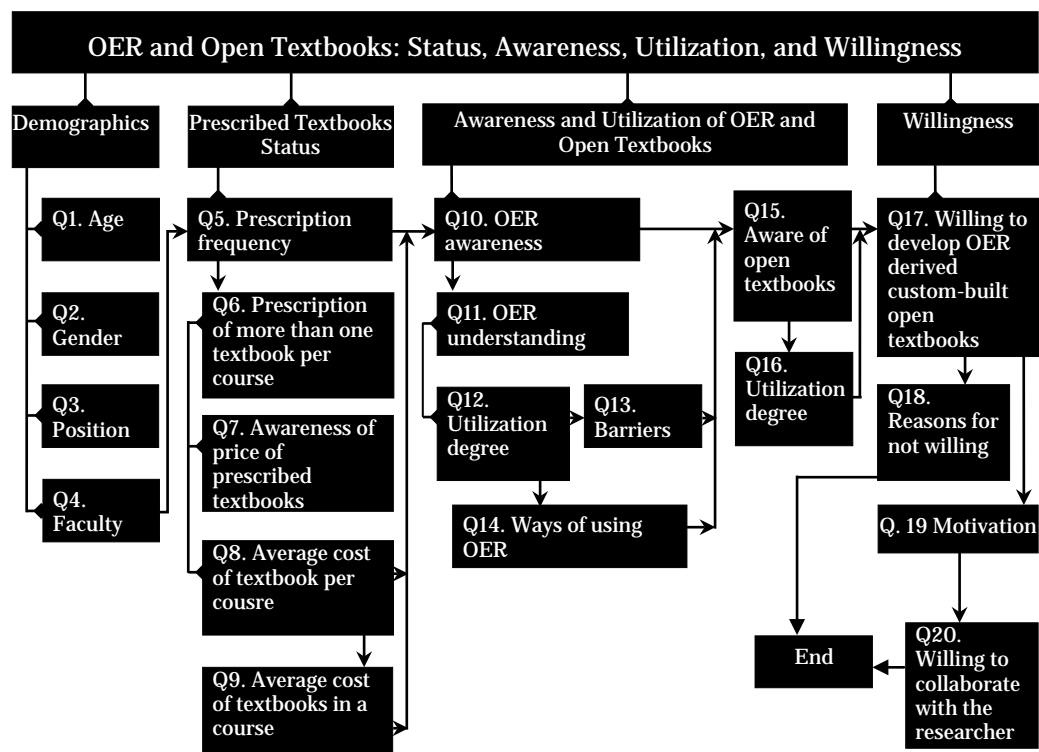

Figure 1. Survey questionnaire framework.

## Sample

The target population for this study was 229 USP teachers including professors, associate professors, senior lecturers, lecturers, and assistant lecturers. These teachers were selected as they coordinate courses and have the authority to prescribe textbooks for their courses. A simple random sampling technique was used to draw 175 samples from the target population as it was the only technique allowing every element of the population the same probability of being selected, in turn reducing sampling bias (Muijs, 2004; Thompson, 2012).

## Survey Procedure

This study was given ethical approval by the USP Research Office. The questionnaire was administered via the tool Google Forms. The primary author sent a hyperlink to the questionnaire along with introductory information through personalised e-mail to 175 university teachers at the USP, encouraging them to respond to the survey. They were informed that their participation in the survey was voluntary and that the survey would take 10-15 minutes to complete. E-mail addresses were obtained for all the participants from the USP website. The data were collected from November 20, 2013 to December 20, 2013. In order to increase the response rate, a reminder to complete the questionnaire was e-mailed on December 9, 2013.

## Survey Analysis

The data gathered through the online questionnaire administered via Google Forms were exported to an MS-Excel worksheet for analysis based on the objectives of the study. The findings of the study are discussed in the next section.

# Results

Out of the 175 questionnaires distributed online, 39 teachers completed the survey, yielding a response rate of 22%. The results from the 39 questionnaires were analysed and are reported according to the four sections noted above: (A) teacher demographics, (B) prescribed textbooks status, (C) awareness and utilization of OER and open textbooks, and (D) willingness towards development of OER derived open textbooks.

## A. Teacher Demographics

Of the 39 teachers who completed the survey, 17 were lecturers, followed by assistant lecturers ( $n = 13$ ), senior lecturers ( $n = 5$ ), associate professors ( $n = 3$ ), and subject coordinators ( $n = 1$ ). The gender distribution of the respondents was 67% male ( $n = 26$ ) and 33% female ( $n = 13$ ). Fifty-one percent of the respondents were between 26 and 40 years old, 33% were between 41 and 55 years old, and the rest, 15%, represented age

groups older than 56, with the mode falling in the 26–40-year age group. Of the total respondents, 15 each came from the FSTE and FBE, and 9 from FALE.

## B. Prescribed Textbooks Status

In the second section of the survey, questions were designed in such a way that the frequency of textbooks prescribed, frequency of more than one prescribed textbook per course, teachers' awareness of the costs of the prescribed textbooks, and average cost of prescribed textbooks in a course could be revealed.

### **Frequency with which teachers prescribe textbooks for their course.**

Teachers were asked how often they prescribed textbooks for their courses; the data showed that 36 out of 39 teachers were involved in the practice of prescribing textbooks. An inspection of Table 1 will further reveal that 69.24% ( $n = 27$ ) of teachers 'very frequently/frequently' prescribed textbooks for their courses, while 23.08% ( $n = 9$ ) 'occasionally/rarely' prescribed textbooks, and 7.69% ( $n = 3$ ) 'never' prescribed textbooks for their courses.

Table 1

*Frequency of Textbooks Prescribed by Teachers for their Courses*

Textbooks prescribed by teachers	Frequency	Percentage
Very frequently	11	28.21
Frequently	16	41.03
Occasionally	5	12.82
Rarely	4	10.26
Never	3	7.69

### **Frequency of more than one textbook prescribed per course.**

Those teachers ( $n = 36$ ) who reported prescribing textbooks were asked how often they prescribed more than one textbook per course. As given in Table 2, 47.22% ( $n = 17$ ) claimed that they rarely prescribed more than one textbook per course; a combined total of 30.56% ( $n = 11$ ) reported 'very frequent/frequent/occasional' prescription of more than one textbook per course; and 22.22% ( $n = 8$ ) of teachers stated that they never prescribed more than one textbook per course.

Table 2

*Frequency of More than One Prescribed Textbook per Course*

More than one prescribed textbook per course	Frequency	Percentage
Very frequently	1	2.78
Frequently	3	8.33
Occasionally	7	19.44
Rarely	17	47.22
Never	8	22.22

**Teachers' awareness of textbook prices before prescription.**

Teachers ( $n = 36$ ) who prescribed textbooks were asked how often they were aware of textbook prices before prescribing them. It was found that 27.78% ( $n = 10$ ) of teachers always knew textbook prices in advance, in contrast to 5.56% ( $n = 2$ ) who were never aware of textbook prices before prescribing them for their courses (Table 3).

Table 3

*Teachers' Awareness of Textbook Prices*

Awariness of textbook prices before prescription	Frequency	Percentage
Always	10	27.78
Very often	13	36.11
Sometimes	8	22.22
Rarely	3	8.33
Never	2	5.56

**Average cost of prescribed textbooks per course.**

When asked the average amount students paid for prescribed textbooks in semester 2, 2013 courses, the majority (47.22%) of teachers reported that the average price of prescribed textbooks for their course was between FJD100 to FJD200 (1 FJD is equivalent to 0.55 USD), 16.67% reported average cost within the range of FJD200-300, 11.11% indicated average cost between FJD000-100, while 25% said that they were not sure of the price (Table 4).

Table 4

*Average Cost of Prescribed Textbooks per Course*

Average price of prescribed textbook	Frequency	Percentage
FJD000-100	4	11.11
FJD100-200	17	47.22
FJD200-300	6	16.67
Not sure	6	25

### C. Awareness and Utilization of OER and Open Textbooks

The third section of the survey was designed to elucidate teachers' awareness, understanding and utilization of OER, their views about barriers for using OER and types of challenges they face while using OER, and to identify their awareness and use of open textbooks. These data shall be useful in drawing appropriate plans for facilitating use of OER for developing open textbooks.

#### **OER awareness and understanding.**

To gauge awareness and understanding of OER, teachers were first asked about the former. From the total 39 teachers, 82% ( $n = 32$ ) affirmed that they were aware of OER, while 18% ( $n = 7$ ) admitted that they were not aware of OER. To gauge understanding, those teachers ( $n = 32$ ) who claimed to be familiar with OER were then asked to explain what the term OER meant to them. Open responses indicated that the majority of teachers who claimed knowledge of OER basically had a fair understanding of the OER concept, though without much in-depth erudition on its benefits and convolutions. Below are some of the more precise responses:

Open educational resources - free online resources that can be freely used in the development of a course without infringing copyright.

OER to me is pathway to achieve Education for All.

Free educational materials available online.

Educational materials that are accessible to and can be used by the general public for free of charge.

Resources that can be used for teaching & learning as well as for research purposes and are available free and freely accessible.

### Use of OER.

Teachers ( $n = 32$ ) who claimed familiarity with OER were asked whether they used OER content in their teaching or course delivery. Regardless of their familiarity with OER, 31.25% ( $n = 10$ ) reported to have never used OER, while of the 68.75% ( $n = 22$ ) who claimed to have used OER, only 12.50% ( $n = 4$ ) utilized OER to a great extent (Table 5).

Table 5

#### *OER Use*

Do you use OER content in your teaching or course delivery?	Frequency	Percentage
Yes, to a limited extent.	9	28.13
Yes, to some extent.	9	28.13
Yes, to a great deal.	4	12.5
No, not at all.	10	31.25

### Barriers to using OER.

Those teachers ( $n = 10$ ) who reported awareness of OER but having never used them were asked to identify and rate what they considered to be the most significant barriers to OER use from a list of 12 barrier statements; these are summarized in Table 6 in rank order, frequency, percentage, and barrier strength on a scale of '1' (*strongly disagree*) to '5' (*strongly agree*). The greatest barriers identified were time limitations restricting accessing relevant OER, inadequate training on OER, insufficient multimedia skills to use OER, uncertainties over copyright-related practices, and difficulties with finding appropriate and quality OER. This was followed by lack of instructional design support and incentives to use OER. Lack of OER policies, insufficient support from management, lack of role models, and lack of quality OER were the bottommost barriers.

Table 6

*Barriers to Using OER*

Rank	Barriers	Frequency	Barrier strength (mean)
1	Lack of time to find relevant and quality OER.	9 (90%)	4.5
2	Lack of training on OER.	8 (80%)	3.9
2	Lack of multimedia skills to use OER.	8 (80%)	3.9
3	Lack of understanding about copyright and openness	8 (80%)	3.8
4	Lack of ability to find relevant and quality OER.	7 (70%)	2.8
5	Lack of instructional design support to use OER.	6 (60%)	2.6
6	Lack of incentives to use OER.	5 (50%)	2.3
7	Lack of policies at the university to support the use of	4 (40%)	1.5
8	Lack of support from management.	3 (30%)	1.3
9	Lack of interest in using OER.	2 (20%)	1
10	No role models to follow.	3 (30%)	0.5
10	Lack of quality OER in my subject area.	1 (10%)	0.5

**Ways of using OER.**

Amongst the teachers ( $n = 22$ ) using OER, it was found that 68.18% ( $n = 15$ ) were involved in the practice of reusing OER content in its original form, while 18.18% ( $n = 4$ ) were revising the content, and only 13.64% ( $n = 3$ ) were remixing the content with other open content to create something new (Table 7). This exhibits that USP teachers are more comfortable with using OER in an 'as is' form. This situation may exist due to their lack of ability to repurpose OER for more contextualized use.

Table 7

*Ways Teachers Use OER*

Statements	Frequency	Percentage
I reused the content in its unaltered/verbatim form.	15	68.18
I adapted, adjusted, modified, or altered the content itself.	4	18.18
I combined the original or revised content with other content to create something new.	3	13.64

**Challenges using OER.**

Those teachers ( $n = 22$ ) who had used OER were asked to describe challenges they most often encountered during its use. The challenges disclosed were common to the top four ranked barriers to using OER, namely, insufficient time to search for OER, lack of knowledge about OER, confusion with open licenses, and software compatibility issues. Conversely, three teachers reported that they did not face any difficulty using OER. Upon further investigation, the data revealed that these teachers ( $n = 3$ ) were primarily



involved in the practice of reusing OER in its original form and using OER to a limited extent. This suggests that these teachers may most likely come across hurdles once they start making frequent use of OER.

### **Open textbooks awareness and use.**

Teachers were asked to indicate their familiarity with open textbooks. To ensure accurate interpretation, the questionnaire included a definition of “open textbook” as follows:

Open Textbooks are freely accessible digital textbooks that can be read online, self-printed or download via any computer with Internet access at no or low cost. In addition, students may often be able to order a commercial “print on demand” copy of an open textbook at a modest cost. (Florida Distance Learning Consortium, 2011)

From Table 8, it is revealed that 25.64% ( $n = 10$ ) of teachers were not aware of open textbooks compared with a majority 74.36% ( $n = 29$ ) who were. Among those who were aware of open textbooks, 23.08% ( $n = 9$ ) reported having used part of or an entire open textbook in their courses. Teachers who reported having used open textbooks were further asked to list the course(s) in which they had used open textbooks and to indicate whether they had used part of or an entire open textbook. The results reveal that 12 open textbooks were utilized in 12 courses and further show that, of these 12 open textbooks, one entire and two partial open textbooks were used in three postgraduate courses, while three entire and six partial open textbooks were used in nine undergraduate courses. This demonstrates that some USP teachers are using open textbooks to some extent, though their utilization of open textbooks may be confined to ‘as-it-is’ use.

Table 8

#### *Open Textbooks Awareness and Use*

Statements	Frequency	Percentage
I have not heard of open textbooks.	10	25.64
I have heard of open textbooks.	5	12.82
I have heard of open textbooks but have never searched for any.	8	20.51
I have looked at some open textbooks.	7	17.95
I have used part or an entire open textbook in my course(s).	9	23.08

The overall response to this question was quite surprising. The data showed four teacher types: those aware of both OER and open textbooks; aware of one but not the other; or unaware of either, as Figure 2 illustrates. Out of 29 teachers who reported to know about open textbooks, three of them had earlier reported that they were not aware of OER. In contrast, six teachers who had previously reported to know about OER were not aware of open textbooks, while 24 teachers were aware of both open textbooks and OER, and eight were unaware of both. These results offer compelling evidence that some USP teachers lack awareness in regards to the diversity of OER and confirm that most have surface-level understanding of the concept of OER.

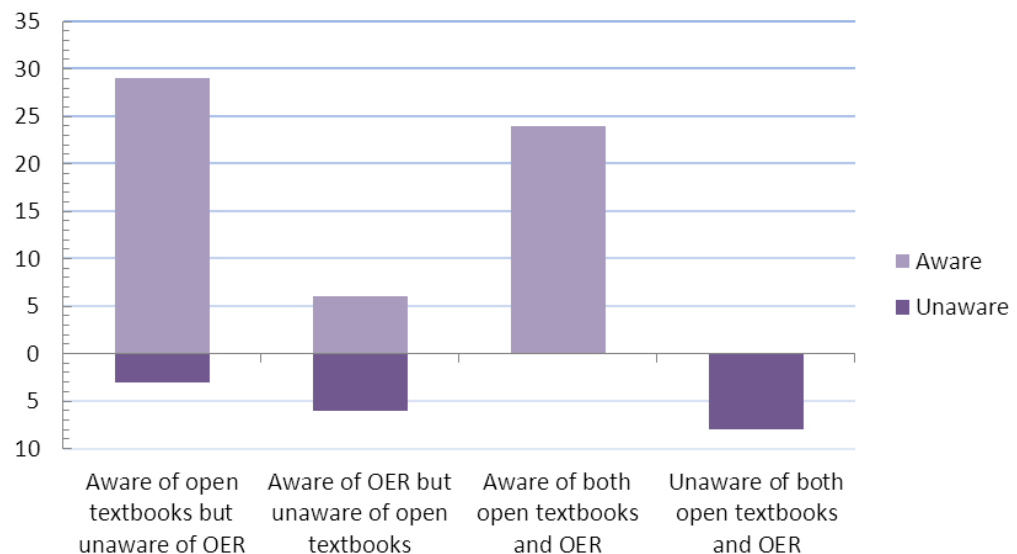

Figure 2. Awareness on open textbooks and OER over four teacher types.

#### D. Willingness Towards Development of OER Derived Custom-Built Open Textbooks

The final section of the survey was designed to identify teachers willing to develop OER derived custom-built open textbooks for their courses. Those teachers who were willing to develop were asked to identify possible motivating factors, while the unwilling teachers were asked to give reasons for their unwillingness. Such information shall be useful in formulating strategies for preparing teachers for OER based custom-built open textbook development.

##### Willingness to develop OER derived custom-built open textbooks.

As Table 9 illustrates, 43.59% ( $n = 17$ ) of teachers reported they planned to develop custom-built OER derived open textbooks for some or all of their courses in the near future, while a small minority of 7.69% ( $n = 3$ ) said that they would not be willing to

develop custom-built OER derived open textbooks for their courses. A combined total of 48.72% ( $n = 19$ ) for 'maybe' and 'undecided' reflected teachers' indecisiveness towards development of OER derived custom-built open textbooks. Upon further analysis, the data revealed that amongst the willing teachers ( $n = 17$ ), 11 of them were aware of both OER and open textbooks, two were unfamiliar with either, one knew about open textbooks but did not know about OER, and three were aware only of OER prior to the survey. The significance of this revelation is that it demonstrates teachers who prior to this survey were unacquainted with OER or open textbooks are still willing to develop OER derived open textbooks. It appears that the survey acted as a medium to introduce the potential of OER and open textbooks to those who were previously uninformed.

Table 9

*Willingness to Develop Open Textbooks*

Willingness to develop OER derived custom-built open textbooks	Frequency	Percentage
No	3	7.69
Maybe	16	41.03
Undecided	3	7.69
Yes, for some of my courses.	14	35.9
Yes, for all my courses.	3	7.69

**Motivators towards OER derived open textbook development.**

Those teachers ( $n = 17$ ) who stated willingness to develop open textbooks were asked to identify and rate the strength of motivating factors that influenced their decision from a preselected list of 10 possible motivator statements. Table 10 outlines the frequency, percentage, motivator strength, and the rank of these 10 items. As illustrated, on a scale of '1' (*strongly disagree*) to '5' (*strongly agree*), the motivator strength ranged from a high of 4.88 for the item 'Bring down cost for my students' to a low of 1.59 for the item 'Personal interest to develop open textbooks'.

Table 10

*Motivators to Develop OER Derived Custom-Built Open Textbooks*

Rank	Motivators	Frequency	Motivator strength (mean)
1	Bring down cost for my students.	17 (100%)	4.88
2	Open textbooks will better fit my instructional needs.	17 (100%)	4.47
3	Become independent of publishers.	17 (100%)	4.35
3	Possibility of credit towards promotion.	17 (100%)	4.35
4	Provide more current materials than traditional	17 (100%)	4.24
5	Good for my professional development.	17 (100%)	4
6	Peer recognition, prestige and status.	17 (100%)	3.65
7	I believe in the open sharing of educational resources.	17 (100%)	3.41
8	Insufficient copies of textbooks in university. bookshop.	13	2.65
9	Personal interest to develop open textbooks.	9	1.59

**Reasons for unwillingness.**

Those teachers ( $n = 3$ ) who said that they would not be willing to develop custom-built OER derived open textbooks for their courses were asked to provide explanations for their decisions. Exact responses from each teacher are given below.

Teacher 1: I'm not convinced that the content that we teach are not being addressed through joint use of prescribed texts and supplemental books.

Teacher 2: It's all dependent on time as most of us are very busy given our own workload.

Teacher 3: I am still not sure about copyright issues and how much I can use online text books. I would like to have these questions answered before I use this in my courses.

**Teachers willing to collaborate with the researcher.**

The intention of this item was to identify teachers with whom the primary author could collaborate to initiate an OER derived open textbook development project at the USP. Teachers ( $n = 17$ ) who conveyed their willingness to develop custom-built OER derived open textbooks for some or all of their courses were asked whether they would be interested in collaborating with the primary author to develop custom-built OER derived open textbooks for their course(s). Out of 17 expectant teachers, 13 teachers affirmed that they would be willing to cooperate with the primary author, while four declined. Teachers who answered affirmatively were asked to email the primary author for further discussions. All 13 agreeable teachers emailed the primary author, expressing

their interest in working together for the development of OER derived open textbooks for their course(s).

## Discussion

Bliss et al. (2013) claimed that significant cost savings are possible by displacing traditional publisher textbooks with open textbooks; however, they also cautioned that students can save money with open textbooks only if teachers are willing to develop them. In light of this postulation, this paper is a modest contribution toward the ongoing discussions on OER and open textbooks. The present study has made an attempt to assess the state of prescribed textbooks and possibilities to initiate custom-built OER derived open textbook development at the USP.

In regard to textbooks, it was found that 92.30% (36/39) of USP teachers prescribed publisher textbooks for their courses. As expected, 28 of them were involved in the practice of prescribing more than one textbook per course. Mostly, the average cost of textbook per course was found to fall in the range of FJD100-200 (1 FJD is equivalent to 0.55 USD). Not surprisingly, only 10 out of 36 teachers were found to be consistently aware of the price of textbooks before prescribing them for their courses. In the light of these findings, we estimate that USP students are likely to spend approximately FJD400 on textbooks each semester.

Regarding OER awareness, while most teachers had heard of the term OER, most lacked a clear understanding of its concept. Out of 39 teachers, 82% ( $n = 32$ ) conveyed that they knew about OER. However, closer examination of the results revealed that six out of the 32 teachers who reported familiarity with OER were not aware of open textbooks, while three out of seven who had not heard of OER were aware of open textbooks. On the other hand, amongst the total 39 teachers, 29 (74%) knew of open textbooks, but three did not know about OER, while amongst the 10 who had not heard of open textbooks, six knew about OER. These findings indicate that there are four types of teachers at USP: those aware of both OER and open textbooks (two types); aware of one but not the other; or unaware of either. The analysis confirms that some USP teachers are not well versed with the concept of OER. This finding is consistent with those of Chen and Panda (2013) who found that most teachers “were acquainted with OER, but at a rather superficial level, without much in-depth understanding of the intricacies involved in it” (p. 13). In their study, they found teachers were not familiar with different types of resources available as OER, which seems to be the case at USP. This calls for OER awareness raising initiatives at USP.

Regarding utilization of OER and open textbooks, only limited use was found. Of the 32 teachers who knew about OER, 22 used OER, and of these, only four utilized it to a great extent. Similar results were reported by Gunness (2011). The findings of the current study show that teachers mainly used OER in unaltered forms. With regard to open

textbook usage, while increasing adoption by teachers was encouraging, the number of teachers using open textbooks remains small, with only 23.08% (9/39) of teachers found to have used open textbooks. Limited use of open textbooks was also reported in the *2012 Faculty and Administrator Open Educational Resources Survey* (Florida Virtual Campus, 2012). USP teachers' lack of awareness and understanding of OER and open textbooks is likely a reason for this low extent of utilization.

Turning to the question of what inhibits teachers from using OER, this study found that lack of time to find relevant and quality OER, insufficient training, inadequate multimedia skills, confusion over copyright-related matters, and lack of ability to find relevant and quality OER ranked as the top-most barriers. Those teachers who were using OER encountered similar obstacles. This finding is in agreement with Atenas, Havemann, and Priego (2014), who showed that time consumption, search ability, lack of training, licensing issues, and technical skills were the main barriers. Interestingly, lack of OER policies as a barrier to using OER was ranked only seventh and thus much lower than previous research has reported (Andrade et al., 2011). Nevertheless, on reflection, all the top-ranking barriers had a skill element incorporated within them. It could be argued that the teachers were more concerned about 'know-how' of using OER than policy matters, meaning that continuous training and support is required in order to widen participation in OER practice at USP.

The results showed that a high proportion of the USP teachers surveyed are willing to develop OER derived custom-built open textbooks for their courses. Amongst the total 39 teachers who responded to the survey, 43.59% ( $n = 17$ ) showed willingness towards OER derived open textbook development, and 13 of these 17 teachers are willing to jointly work together with the primary author to develop OER derived open textbooks for their courses. These teachers appear keen in developing open textbooks for their courses to address textbook affordability despite a lack of incentives and absence of an OER policy at the USP. The list of motivating factors identified in the current study was in line with a previous study by Pegler (2012). The current study reveals that reducing cost for students, customizability to meet instructional requirements, becoming independent of publishers, and possibility of credit towards promotion are the dominant motivating factors to teachers.

The most striking result to emerge from the study is that amongst the 17 teachers who affirmed their intention to develop OER derived open textbooks, two were aware of neither OER nor open textbooks, one was familiar with open textbooks but did not know about OER, and three were aware only of OER prior to the current study. This finding was unexpected, indicating that the current study made them aware of the concept and potential of OER which may have influenced their decision. Also it could be that the motive for these teachers to become engaged in open textbook development is for publicity and to gain first-mover advantage (OCED, 2007).

Bliss et al. (2013) noted that students can save money with open textbooks only if teachers are willing to develop them, and the fact that a good number of teachers ( $n = 17$ ) are willing to do so for their courses is a good indicator to start open textbook initiatives at USP. One approach to kick-starting such an initiative is to begin by developing one textbook at a time (Morris-Babb & Henderson, 2012). The primary author is currently working with nine USP teachers to develop a custom-built OER derived open textbook for a postgraduate course entitled “AL400 Research Methodologies in the Humanities and Social Sciences”. These nine teachers team teach this course and were identified as a result of this study. In actuality, the coordinator of this course was one of those teachers who agreed to cooperate with the principal author to develop an OER derived custom-built open textbook for his course. Later, the course coordinator convinced the rest of the teaching team to join the project. Apart from producing an open textbook, the result of the ongoing project is anticipated to provide design principles and ‘how-to’ guidelines for developing custom-built OER derived open textbooks to the teachers of the case study university. The experiences of this project will be disseminated through future publications and shall be built on the research findings reported in this paper.

## References

- Acker, S. R. (2011). Digital textbooks: A state-level perspective on affordability and improved learning outcomes. *Library Technology Reports*, 47(8), 41–52.
- Allen, N. (2011). High prices prevent college students from buying assigned textbooks. *Student PIRGs*. Retrieved from <http://www.studentpirgs.org/news/ap/high-prices-prevent-college-students-buying-assigned-textbooks>
- Andrade, A., Ehlers, U.-D., Caine, A., Carneiro, R., Conole, G., Kairamo, A.-K., ... Holmberg, C. (2011). *Beyond OER: Shifting focus to open educational practices*. Due-Publico, Essen. Retrieved from <http://www.oerasia.org/OERResources/8.pdf>
- Atenas, J., Havemann, L., & Priego, E. (2014). Opening teaching landscapes: The importance of quality assurance in the delivery of open educational resources. *Open Praxis*, 6(1), 29–43.
- Atkins, D. E., Brown, J. S., & Hammond, A. L. (2007). A review of the open educational resources (OER) movement: Achievements, challenges, and new opportunities. Retrieved from <http://www.hewlett.org/uploads/files/ReviewoftheOERMovement.pdf>
- Baraniuk, R. G. (2013). Opening education. *The Bridge*, 43(2), 41–47. doi:10.1126/science.1168018
- Bliss, T., Hilton, J., Wiley, D., & Thanos, K. (2013). The cost and quality of online open textbooks: Perceptions of community college faculty and students. *First Monday*, 18(1). Retrieved from <http://firstmonday.org/ojs/index.php/fm/article/view/3972/3383>
- Carpenter, P., Bullock, A., & Potter, J. (2006). Textbooks in teaching and learning. *Brookes eJournal of Learning and Teaching*, 2(1). Retrieved from [http://bejlt.brookes.ac.uk/paper/textbooks\\_in\\_teaching\\_and\\_learning-2/](http://bejlt.brookes.ac.uk/paper/textbooks_in_teaching_and_learning-2/)
- Chen, Q., & Panda, S. (2013). Needs for and utilization of OER in distance education: a Chinese survey. *Educational Media International*, 50(2), 77–92. doi:10.1080/09523987.2013.795324
- Florida Distance Learning Consortium. (2011, September). *Florida student textbook survey*. Tallahassee, FL: Author. Retrieved from [http://www.openaccesstextbooks.org/%5Cpdf%5C2010\\_FSTS\\_Report\\_01SEP2011.pdf](http://www.openaccesstextbooks.org/%5Cpdf%5C2010_FSTS_Report_01SEP2011.pdf)



- Florida Virtual Campus. (2012, August). *2012 faculty and administrator open educational resources survey*. Tallahassee, FL: Author. Retrieved from [http://www.openaccesstextbooks.org/%5Cpdf%5C2012\\_Faculty-Admin\\_OER\\_Survey\\_Report.pdf](http://www.openaccesstextbooks.org/%5Cpdf%5C2012_Faculty-Admin_OER_Survey_Report.pdf)
- Graydon, B., Urbach-Buholz, B., & Kohen, C. (2011). A study of four textbook distribution models. *Educause Quarterly*, 34(4). Retrieved from <http://www.educause.edu/ero/article/study-four-textbook-distribution-models>
- Gunness, S. (2011). Learner-centred teaching through OER. In A. Okada (Ed.), *Open educational resources and social networks: Co-learning and professional development*. London: Scholio Educational Research & Publishing. Retrieved from [http://oer.kmi.open.ac.uk/?page\\_id=2329](http://oer.kmi.open.ac.uk/?page_id=2329)
- Hallam, G. (2012). Briefing paper on eTextbooks and third party eLearning products and their implications for Australian university libraries. Retrieved from <http://eprints.qut.edu.au/55244/3/55244P.pdf>
- Hilton, J., Gaudet, D., Clark, P., Robinson, J., & Wiley, D. (2013). The adoption of open educational resources by one community college math department. *The International Review of Research in Open and Distance Learning*, 14(4). Retrieved from <http://www.irrodl.org/index.php/irrodl/article/view/1523/2652>
- Hilton, J., & Wiley, D. (2011). Open-access textbooks and financial sustainability: A case study on Flat World Knowledge. *The International Review of Research in Open and Distance Learning*, 12(5). Retrieved from <http://www.irrodl.org/index.php/irrodl/article/view/960/1860>
- Koul, L. (2009). *Methodology of educational research* (4<sup>th</sup> ed.) VIKAS Publishing House Pvt Ltd.
- Morris-Babb, M., & Henderson, S. (2012). An experiment in open-access textbook publishing: Changing the world one textbook at a time. *Journal of Scholarly Publishing*, 43(2), 148–155. doi:10.3138/jsp.43.2.148
- Muijs, D. (2004). *Doing quantitative research in education with SPSS*. London, GBR: SAGE Publications Inc. (US). Retrieved from <http://site.ebrary.com/lib/unisouthernqld/docDetail.action?docID=10080884>
- OCED. (2007). *Giving knowledge for free: The emergence of open educational resources*. Paris. Retrieved from <http://www.oecd.org/edu/ceeri/38654317.pdf>

- Okamoto, K. (2013). Making higher education more affordable, one course reading at a time: Academic libraries as key advocates for open access textbooks and educational resources. *Public Services Quarterly*, 9(4), 267–283. doi:10.1080/15228959.2013.842397
- Pegler, C. (2012). Herzberg, hygiene and the motivation to reuse: Towards a three-factor theory to explain motivation to share and use OER. *Journal of Interactive Media in Education*, 1–18. Retrieved from [http://www-jime.open.ac.uk/jime/article/viewArticle/2012-04/html](http://www.jime.open.ac.uk/jime/article/viewArticle/2012-04/html)
- Perry, M. (2012). *The college textbook bubble and how the “open educational resources” movement is going up against the textbook cartel*. American Enterprise Institute. Retrieved January 03, 2014, from <http://www.aei-ideas.org/2012/12/the-college-textbook-bubble-and-how-the-open-educational-resources-movement-is-going-up-against-the-textbook-cartel/>
- Punch, K. (2005). *Introduction to social research: Quantitative and qualitative approaches* (2<sup>nd</sup> ed.). SAGE Publications Inc. (US).
- Schonlau, M., Fricker, R. D., & Elliott, M. N. (2002). *Conducting research surveys via e-mail and the Web*. Santa Monica, CA, USA: RAND Corporation. Retrieved from <http://site.ebrary.com/lib/unisouthernqld/docDetail.action?docID=10425077>
- Senack, E. (2014). *Fixing the broken textbook market: How students respond to high textbook costs and demand alternatives*. Washington, DC. Retrieved from [http://www.washpirg.org/sites/pirg/files/reports/1.27.14 Fixing Broken Textbooks Report.pdf](http://www.washpirg.org/sites/pirg/files/reports/1.27.14%20Fixing%20Broken%20Textbooks%20Report.pdf)
- Thompson, S. K. (2012). *Wiley Desktop Editions: Sampling* (3<sup>rd</sup> ed.). Somerset, NJ, USA: Wiley. Retrieved from <http://site.ebrary.com/lib/unisouthernqld/docDetail.action?docID=10630536>
- Wiley, D., Green, C., & Soares, L. (2012). Dramatically bringing down the cost of education with OER. *Center for American Progress*. Retrieved October 13, 2013, from <http://www.americanprogress.org/issues/labor/news/2012/02/07/11167/dramatically-bringing-down-the-cost-of-education-with-oer/>
- Wiley, D., Hilton, J. L., Ellington, S., & Hall, T. (2012). A preliminary examination of the cost savings and learning impacts of using open textbooks in middle and high school science classes. *The International Review of Research in Open and Distance Learning*, 13(3). Retrieved from <http://www.irrodl.org/index.php/irrodl/article/view/1153/2256>

Athabasca University 



## Characteristics and Activities of Teachers on Distance Learning Programs that Affect Their Ratings

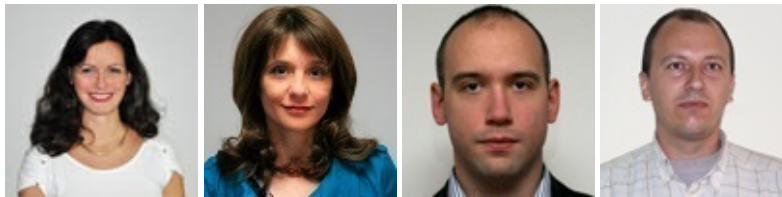

Svetlana M. Stanišić Stojić, Gordana Dobrijević, Nemanja Stanišić, and Nenad Stanić  
Singidunum University, Serbia

### Abstract

This paper presents an analysis of teachers' ratings on distance learning undergraduate study programs: 7,156 students enrolled in traditional and 528 students enrolled in distance learning studies took part in the evaluation questionnaire, assessing 71 teachers. The data were collected from the Moodle platform and from the Singidunum University information system, and then analysed with SPSS statistical software. The parameters considered as potentially affecting teacher ratings are: number of teachers engaged in a particular course, total number of courses in which the teacher is engaged, teacher's gender and age, total number of the available resources, and so forth. The results imply that scores assigned to individual teachers are consistent in both traditional and distance learning programs. The average rate was perceived to be lower when there were several teachers in a single course; such an effect was enhanced in cases where there was a significant age discrepancy among them. The other factors considered did not show a significant association with teacher ratings. Students' main remarks about the work of the teachers have been summarised at the end of this paper. Possible explanations and implications of the results are discussed and recommendations are given.

**Keywords:** Distance learning; teacher rating; student satisfaction

## Introduction

Distance learning is becoming increasingly recognised as a suitable and valuable educational experience (Davies, Howell, & Petrie, 2010). Many universities across the globe offer distance learning courses through the introduction of learning management systems that allow them to have both on- and off-campus students. Since recruitment and retention of students has a significant financial impact on today's universities, there have been numerous studies on student satisfaction and academic achievements from distance learning programs (e.g., Endres, Chowdhury, Frye, & Hurtubis, 2009; Eom, Wen, & Ashill, 2006).

One of the main factors influencing student satisfaction is the quality of teaching. This is an especially important consideration for university managers and decision makers, who can organise distance learning in a way that allows them to provide ongoing guidance and improvement strategies for teaching staff. On the contrary, some other factors are not easily influenced and managed, such as student self-motivation, student learning style, required/elective courses ratio, and so forth. Rating teachers should be a valuable procedure for students as well, because it can lead to improvement of teaching quality, based on the stated opinions of the students (Marzano, 2012; Nargundkar & Shrikhande, 2012). The study of Taylor and Tyler (2012) strongly confirms the opinion that teachers develop skills and otherwise improve due to student evaluation. They found that teachers were more successful at improving student achievement during the school year when they were evaluated than in the years before the evaluation, and were even more successful in the years after the evaluation. However, some reports (e.g., Toch & Rothman, 2008) show that teacher evaluations have not helped in the formation of highly skilled teachers. We presume that teachers' ratings could influence their skills development provided that their tenure depends on the rating, the rating is publicly announced (which puts additional pressure on the teacher), and there are some consequences for the teachers with lowest scores. Since there are no widely accepted standards of teacher performance, universities around the world mainly use student evaluation of teachers as the principal source of data on teachers' performance and quality of teaching (Lalla, Frederic, & Ferrari, 2011; Carr & Hagel, 2008). Some previous studies have dealt with the issue of whether and to what extent the evaluation results truly reflect students' attitudes. According to most authors, teacher rating proved to be a good indicator of teaching effectiveness (e.g., Beran & Violato, 2005; Nargundkar & Shrikhande, 2012; Wiers-Jenssen, Stensaker, & Groggaard, 2003). Beran and Violato (2005) also found that teacher rating is, to a lesser extent, biased by some factors that are not related to the teachers themselves, such as students' grade expectations, attendance, and types of courses being evaluated. For example, teachers of elective courses have always been rated higher than teachers of compulsory courses, as shown by all findings to date. In previous research on teacher-related factors that affect ratings, interaction, teacher feedback, and communication appear most often (e.g., Kuo, Walker, Belland, & Schroder, 2013; Loveland, 2007; Rothman, Romeo, Brennan, & Mitchell, 2011). Some other factors having the highest impact on learner satisfaction in online

education are: teacher knowledge and facilitation, course structure (Eom et al., 2006), appropriateness of readings and tasks, technological tools, course organisation, clarity of outcomes and assignments, and content format (Rothman et al., 2011). According to the community of inquiry framework (Garrison, Anderson & Archer, 2000, 2010), a deep and meaningful online learning experience happens through the evolution of three interconnected elements: cognitive, social, and teaching presence. In an educational environment, teaching presence is normally the main responsibility of the teacher. It includes selection, organization, and presentation of the course content, and the design and development of learning activities. Although the teacher's personality is known to be a crucial factor in establishing a successful online learning atmosphere (Northcote, 2010), the most apparent teachers' characteristics, such as their qualification experience, do not always appear to be associated with teaching quality (Hanushek & Rivkin, 2010). Still, expressing the personality beyond the provision of mere resources is important because just the interaction is not enough to achieve a sense of teacher presence in online learning contexts (Garrison, Cleveland-Innes, & Fung, 2010).

Our research was aimed at defining the characteristics and activities that will influence the rating of teachers on distance learning study programs. The data from the evaluation questionnaire, conducted regularly for the quality control of teaching and study processes at Singidunum University, have been used for the research. Singidunum University is the largest private university in Serbia, with more than 10,000 students enrolled in degree programs in the fields of finance, banking, accounting, marketing and trade, tourism and hotel management, engineering management, computer science, and electrical and computer engineering. Six percent (about 600 students) of this number attend distance learning programs from all the abovementioned fields except computer science and electrical and computer engineering. The research results are expected to benefit teaching staff as well as the management of higher education institutions, which aims to improve the quality of teaching delivery and increase satisfaction of students on distance learning programs.

## Method

The research covered all four years of various study programs. The data were collected from both the University information system and the Moodle platform, then cross-analysed by using the SPSS statistical software.

Numerous parameters were analysed as potential correlates of teacher rating, some of them being the number of teachers engaged per course, number of courses assigned to a particular teacher, gender and age of a teacher, total number of the available resources, and students' activities, and so forth. Available resources and students' activities were considered collectively as well as individually against the following categories: files, quizzes, forums, lessons, assignments, labels, and dictionaries. The Pearson correlation was used to measure the ratio between the two variables. Linear regression was used to

define the relationships between the variables, while  $t$  test was used to test the differences in the average values. The method of Spearman's rank-order correlation was used to determine the association between variables that are not normally distributed. In order to test for association between two non-normally distributed variables while simultaneously controlling for the effect of already known confounders, the method of partial Spearman's rank correlation was used.

In order to create a comparison with the traditional studies, this research was conducted on a sample of 71 teachers, simultaneously engaged with both traditional classroom programs and distance learning studies. The total number of students that assessed the work of teachers in traditional classroom programs was 7,156, whereas 528 students assessed the work of teachers on distance learning studies. Each student rated the teachers only during the term s/he was currently in attendance, awarding grades from 1 to 5, 1 being the *lowest*, and 5 the *highest*. The total number of polls completed was 36,151 on traditional studies and 2,675 on distance learning study programs. The evaluation questionnaire comprised five questions:

- Did the teacher provide appropriate learning resources that were prepared in a clear and understandable fashion?
- Is communication with the teacher appropriate, relevant and timely?
- Has the teacher provided you with the necessary theoretical and practical knowledge?
- Is the teacher encouraging critical thinking?
- Is the teacher encouraging inclusion of students into the study process?

Students were also able to leave a comment at the end of the poll, related to the teacher's performance. As the mean evaluation score for the teachers involved more than one course, we used the grand mean they received for all the courses they were involved in. At the end of this paper, we also summarised students' remarks, which were usually given descriptively in the polls.

## Results and Discussion

Because of the differences between online and traditional courses, some researchers have examined if and to what extent the same student ratings can be used in online courses. For example, students of traditional studies establish more frequent personal contact with their teachers, as opposed to the students of distance learning studies. Due to the lack of personal contact and empathy, the rating of distance learning teachers is often more reflective of the quality of the course content than the quality of the overall work of the teacher. This can provide misleading results, particularly with the courses

involving more than one teacher. For these reasons, we divided the courses into modules, with the name of the author clearly given for each online resource. A large number of recorded lectures were also uploaded; the communication on each of the courses was personalised so that the students could easily master the materials and have a clear idea of whom they were communicating with.

Figure 1 represents the distribution of scores that the students awarded to the teachers on traditional studies and distance learning studies. The average values, standard deviations and the sample size are shown in this graph. The obtained results show that there is a positive association between the score awarded to the teacher on traditional studies and the score awarded to the teacher on distance learning studies ( $r(69) = 0.575$ ,  $p < 0.01$ ).

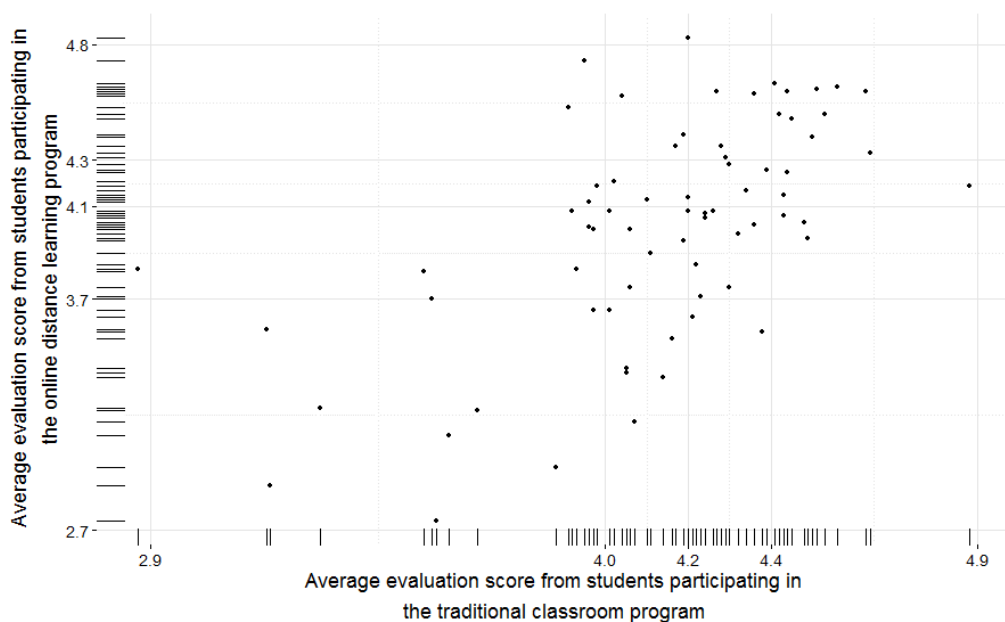

*Figure 1.* Scatter plot of mean evaluation scores received from students participating in the two programs with “rug” density plots on margins.

The linear model has the following form:

Average evaluation score from students participating in the online distance learning program =  $0.880 + 0.756 \times$  average evaluation score from students participating in the traditional classroom program

The reliability analysis has also confirmed that the evaluation scale items are reasonably interrelated (5 items; Cronbach's  $\alpha = 0.82$ ). However, Sijtsma (2009) reminds us that a high value of Cronbach's alpha does not provide evidence of unidimensionality.



Although distance learning involves reduced learner-tutor interaction due to asynchronous computer-mediated (ACM) conferences, it is obvious that certain teachers are able to meet the requirements, regardless of format or mode of delivery. This points to a very important conclusion: "good teaching" is just "good teaching" regardless of the medium. Comparing traditional and online courses, Beattie, Spooner, Jordan, Algozzine, and Spooner (2002) found similar results across course, teacher, and general ratings, regardless of the mode of delivery. Also, in the IDEA survey 2002-2008 by Benton, Webster, Gross, and Pallett (2010), students' ratings of teachers, both of online and traditional courses, as well as ratings of the courses themselves, were all very much alike. They found some minor differences (e.g., that teachers of online courses were perceived as using educational technology more effectively), which is expected given the specifics of the mode of educational material delivery.

According to Alonso Díaz and Blázquez Entonado (2009), teachers' roles in online education are not very different from those of traditional courses. In both teaching modes teachers still have to deal with facilitating the teaching/learning process, combining activities with theoretical content, and encouraging student interaction. Kelly, Ponton, and Rovai (2007) also compared students' ratings of overall instructor performance and overall satisfaction of online and traditional courses. They found no significant difference in students' ratings between online and traditional courses. The authors propose that teachers of online courses should be fair and unbiased, and enthusiastic and helpful, and they should show real interest in student progress and needs.

Based on the data from Table 1, which shows that the average teacher rating on traditional studies is higher than on distance learning studies by 0.13, and the results of paired samples of  $t$  test shown in Table 2, it can be concluded that such a difference is statistically significant ( $t(70) = -2.68, p < 0.01$ ). The effect size for this analysis ( $d = 0.31$ ) is moderate according to the general conventions (Cohen, 1992). One of the reasons for this difference may be the lack of personal contact and empathy. It is well known that communication is experienced differently through different forms of communication media. It is much easier to develop personal understanding and empathy in face-to-face communication than in online communication, which cannot convey delicate social cues beyond the literal meaning of the words from the text (Lewicki, Barry, & Saunders, 2010).

Table 1

*The Mean Evaluation Scores Received from Students Participating in the Online Distance Learning Program and the Traditional Classroom Program*

	Mean	N	Std. deviation	Std. error mean
Distance learning program	4.00	71	0.47	0.055
Traditional program	4.13	71	0.366	0.042

Table 2

*Paired T-Test for Difference in Means between Evaluation Scores Received from Students Participating in the Online Distance Learning Program and the Traditional Classroom Program*

Paired differences							
Mean	Std. deviation	Std. error mean	95% confidence interval of the difference		<i>t</i>	<i>df</i>	Sig. (2-tailed)
			Lower	Upper			
-0.12	0.39	0.047	-0.22	-0.03	-2.68	70	0.009

The second part of our research shifts the point of view from course-oriented to a rather more teacher-oriented one. The results showed that the number of teachers engaged per course is negatively associated with their average score. This association is significant, even when it is controlled for the score on traditional studies, which can be seen in Table 3 ( $rs(173) = -0.196$ ,  $p < 0.01$ ). We assume that this is because of the lack of coordination among different teachers, due to their different ages, personalities, backgrounds, communication styles, and preferences. Another problem in these cases may be an excess of learning material and too many activities on the online platform, because each teacher supplies his/her own resources.

Table 3

*Correlation between Mean Evaluation Scores for Specific Online Courses and the Number of Teaching Staff Involved in these Courses*

	Average evaluation score from students participating in the online distance learning program	Number of teaching staff involved
Correlation	1.00	-0.19
Significance (2-tailed)	-	0.009
<i>df</i>	0	173
Correlation	-0.19	1.00
Significance (2-tailed)	0.009	-
<i>df</i>	173	0

The results also showed that the age difference of the teachers engaged in a particular course reduced the overall average score ( $rs(172) = -0.177$ ,  $p < 0.05$ ). The age difference

is measured by the coefficient of variation (standard deviation of age divided by the average age of the teaching staff).

Table 4

*Correlation between Mean Evaluation Scores for Specific Online Courses and Disparity in Age among Teaching Staff Involved in these Courses*

	Average evaluation score from students participating in the online distance learning program	Coefficient of variation of teaching staff age
Correlation	1.00	-0.18
Significance (2-tailed)	-	0.02
<i>df</i>	0	172
Correlation	-0.18	1.00
Significance (2-tailed)	0.02	-
<i>df</i>	172	0

It is interesting that no statistically significant correlation between other variables has been perceived. The average teacher rating on distance learning studies, for example, is neither related to the number of uploaded teaching resources nor to the number of teachers' activities on the online platform. These results lead to a conclusion that the mere number of the uploaded resources does not indicate their quality, and has no influence on student satisfaction. Estelami (2012), who tested student satisfaction in both hybrid-online courses (a combination of online and traditional classroom teaching) and purely online courses, reached similar conclusions. He defined several key factors that influence student satisfaction and that depend on teachers either directly or indirectly: course content, student-teacher communication, the use of effective learning tools, and the teacher him/herself. Considering the importance of learning tools, he concluded that the usefulness of textbooks and other support material, and not the number of resources, greatly influence students' general feelings and attitudes. Carr and Hagel (2008) also confirm that good quality teaching resources and higher levels of online activity are associated with higher satisfaction levels.

Benton, Cashin, and Kansas's (2012) review of literature and empirical studies revealed that the teacher's personality does not influence student evaluation of teachers, and neither does the teacher's race, gender, age, or research productivity. Paechter, Maier, and Macher (2010) investigated the factors that students regard as important for their satisfaction and performance. The teacher's expertise in online learning and his/her level of support offered seem to be the best predictors for student satisfaction and learning achievements.

The fact that no correlation between the average rating and the age of the teacher was observed also speaks in favor of older generations of teachers being capable of adjusting successfully to the new teaching trends. Table 5 shows the average values and standard deviations of scores on distance learning study programs for two age groups of teachers, while Table 6 shows the results of *t* test, both of which confirm that difference in the average score does not depend on the teacher's age.

Table 5

*Mean Evaluation Scores Received from Students Participating in the Online Distance Learning Program, Categorised by Teaching Staff Age Groups*

The age of a teacher	<i>N</i>	Mean	Std.deviation	Std. error mean
< 40 years	36	4.00	0.43	0.07
>=40 years	35	4.01	0.51	0.09

Table 6

*T-Test for Difference in Mean Evaluation Scores between Teaching Staff Age Groups, Received from Students Participating in the Online Distance Learning Program*

Levene's test for equality of variances		<i>t</i> -test for equality of means						
<i>F</i>	Sig.	<i>t</i>	<i>df</i>	Sig. (2-tailed)	Mean diff.	Std. error diff.	95% confidence interval of the difference	
							Lower	Upper
1.03	0.31	-0.03	69.00	0.97	-0.004	0.11	-0.23	0.22
		-0.03	66.62	0.97	-0.004	0.11	-0.23	0.22

It was not observed that the teachers engaged in more than one course had an average score lower than the mean value, which indicates that the workload of teachers, as long as it is within acceptable limits, is not a factor that affects the quality of work.

Finally, we have summarised the most common objections to the work of teachers, which the students presented descriptively in the evaluation questionnaire. We believe that these remarks may help to understand the factors that affect students' satisfaction, and may also help to improve the teaching quality in distance learning study programs. As Kelly, Ponton, and Rovai (2007) posit, if there are differences between quantitative ratings of online and traditional courses, analysis of qualitative comments can provide us greater insight into those differences.

First of all, some teachers delay responses to students' messages without apparent reason, and communication is sometimes scant, without necessary details. Communication with students on distance learning programs requires special attention, due to the fact that this type of study involves the increasing use of asynchronous video communication, as well as a lack of personal contact, which is essential for the development of trust (Dennen, Aubteen Darabi, & Smith, 2007). According to Wade, Cameron, Morgan, and Williams (2011), distance education students desire relationships with group members more than their colleagues enrolled in traditional study programs, and we can add that the same applies to their relationships with teachers. Furthermore, it has been established that facilitating students' participation is one of the essential pedagogical competencies specific for e-learning practices (Muñoz Carril, González Sanmamed, & Hernández Sallés, 2013).

Second, students find that some teachers do not upload enough learning and testing resources suitable for distance learning. The Moodle platform, which is nowadays used in many countries, offers a wide variety of content, applications, and forms of communication available in the e-learning environment, with a detailed description of options (Akhmetova, Vorontsova, & Morozova, 2013). Therefore, distance learning can rely on many technologies and features such as multimedia, streaming audio and video, web conferencing, instant messaging, peer-to-peer file sharing, and so on (McGreal & Elliott, 2008). However, apart from video tutorials and assessment tests with automatic feedback, such possibilities are rarely used, fully due to the omission in work of the teaching staff.

The third objection, which is frequently encountered, is that most teachers set deadlines for the preparation of tests, mid-terms and finals, which do not fit all the students. The cause of the problem probably lies in the fact that the flexibility of online learning is too often taken for granted, and students interpret it as doing online assignments whenever it suits them. Although this interpretation is true of most online courses, sometimes students can have problems resulting from regular absence from online classes. Learners need to rely on stable terms and tasks, so that they can plan for their absence in advance. On the other hand, it is essential that the teachers provide more support to the students when they (the students) underestimate the time and effort required in online learning, since the lack of support is shown to be one of the main reasons for dropping out of university (Conrad, 2009).

In the end, we should consider certain constructive remarks given by some authors with respect to teacher evaluations. Wiers-Jensen et al. (2003) state that evaluating student satisfaction remains controversial due to the contextual factors that can influence students' perception of teaching quality. Several other authors (e.g., Becker & Watts, 1999; D'Apollonia & Abrami, 1997) also found that students' ratings are often influenced by teacher characteristics that have nothing to do with effectiveness, such as popularity or grading style. Still, many universities use student evaluation of teachers as the main factor in faculty promotion and salary, which raises a number of issues (e.g., Olivares, 2003), including the validity (whether the results can accurately predict student

learning) and external biases (whether some other unrelated factors could influence student opinion) of such evaluations. It can also induce teachers to manipulate their grading policies, in order to boost their evaluations, which can ultimately lead to deterioration of education quality (Johnson, 2002). Griffin, Hilton, Plummer, and Barret (2014) analysed the grade point averages (GPAs) and teacher ratings over 2,073 courses at a large private university. They found a moderate correlation between GPAs and teacher ratings, although this overall correlation did not hold true for individual teachers and courses. Although student ratings are useful in assessing the quality of teaching and of overall courses, they are not sufficient and therefore should not be used as a sole factor in determining teacher salary and promotion.

## Conclusions

In this paper we analysed the main teacher-related factors that affect student evaluation of teachers on distance learning programs. The results show only a small reduction in ratings on DL studies, compared to traditional studies. The reason for this may be the lack of personal contact between students and teachers. We also found that the number of teachers engaged per course, as well as their age difference, lowered the average rating of the teachers involved in the course. On the other hand, no correlation was found between teacher ratings and teachers' activities on the online platform, or the number of resources they uploaded. It shows that students appreciate more the quality and suitability than the quantity of learning materials. In order to improve distance learning education, teachers should devote special attention to communicating with students. When it comes to learning materials, teachers should use the advantages of the Moodle platform and give priority to the resources adapted to online learning, such as online tutorials and feedback on assignments.

## References

- Akhmetova, D., Vorontsova, L., & Morozova, I. G. (2013). The experience of a distance learning organization in a private higher educational institution in the Republic of Tatarastan (Russia): From idea to realization. *International Review of Research in Open & Distance Learning, 14*(3).
- Beattie, J., Spooner, F., Jordan, L., Algozzine, B., & Spooner, M. (2002). Evaluating instruction in distance learning classes. *Teacher Education and Special Education: The Journal of the Teacher Education Division of the Council for Exceptional Children, 25*(2), 124-132.
- Becker, W. E., & Watts, M. (1999). How departments of economics evaluate teaching. *American Economic Review, 89*(2), 344-349.
- Benton, S. L., Webster, R., Gross, A. B., & Pallett, W. H. (2010). *Technical report No. 15: An analysis of IDEA student ratings of instruction in traditional versus online courses 2002-2008 data*. The IDEA Center: Manhattan, Kansas.
- Benton, S. L., Cashin, W. E., & Kansas, E. (2012). *IDEA paper No. 50: Student ratings of teaching: A summary of research and literature*. The IDEA Center: Manhattan, Kansas.
- Beran, T., & Violato, C. (2005) Ratings of university teacher instruction: How much do student and course characteristics really matter? *Assessment & Evaluation in Higher Education, 30*(6), 593-601.
- Carr, R., & Hagel, P. (2008, January). Students' evaluations of teaching quality and their unit online activity: An empirical investigation. In *ASCILITE 2008 Melbourne: Hello! Where are you in the landscape of educational technology?: Program and abstracts for the 25th ASCILITE conference* (pp. 152-159). Deakin University: ASCILITE.
- Cohen, J. (1992). A power primer. *Psychological Bulletin, 112*(1), 155-159.
- Conrad, D. (2009). Cognitive, instructional, and social presence as factors in learners' negotiation of planned absences from online study. *International Review of Research in Open & Distance Learning, 10*(3).
- D'Apollonia, S., & Abrami, P. C. (1997). Navigating student ratings of instruction. *American Psychologist, 52*(11), 1198.
- Davies, R. S., Howell, S. L., & Petrie, J. A. (2010). A review of trends in distance education scholarship at research universities in North America, 1998-2007. *International Review of Research in Open & Distance Learning, 11*(3).

- Dennen, V. P., Aubteen Darabi, A., & Smith, L. J. (2007). Instructor–learner interaction in online courses: The relative perceived importance of particular instructor actions on performance and satisfaction. *Distance Education, 28*(1), 65-79.
- Díaz, L. A., & Entonado, F. B. (2009). Are the functions of teachers in e-learning and face-to-face learning environments really different? *Journal of Educational Technology & Society, 12*(4), 331-343.
- Endres, M. L., Chowdhury, S., Frye, C., & Hurtubis, C. A. (2009). The multifaceted nature of online MBA student satisfaction and impacts on behavioral intentions. *Journal of Education for Business, 84*(5), 304-312.
- Eom, S. B., Wen, H. J., & Ashill, N. (2006). The determinants of students' perceived learning outcomes and satisfaction in university online education: An empirical investigation. *Decision Sciences Journal of Innovative Education, 4*(2), 215-235.
- Estelami, H. (2012). An exploratory study of the drivers of student satisfaction and learning experience in hybrid-online and purely online marketing courses. *Marketing Education Review, 22*(2), 143-156.
- Garrison, D. R., Anderson, T., & Archer, W. (2000). Critical inquiry in a text-based environment : Computer conferencing in higher education. *The Internet and Higher Education, 2*(2-3), 87-105.
- Garrison, D. R., Anderson, T., & Archer, W. (2010). The first decade of the community of inquiry framework: A retrospective. *The Internet and Higher Education, 13*(1), 5-9.
- Garrison, D. R., Cleveland-Innes, M., & Fung, T. S. (2010). Exploring causal relationships among teaching, cognitive and social presence: Student perceptions of the community of inquiry framework. *The Internet and Higher Education, 13*(1), 31-36.
- Griffin, T. J., Hilton III, J., Plummer, K., & Barret, D. (2014). Correlation between grade point averages and student evaluation of teaching scores: Taking a closer look. *Assessment & Evaluation in Higher Education, 39*(3), 1-10.
- Hanushek, E. A., & Rivkin, S. G. (2010). Generalizations about using value-added measures of teacher quality. *The American Economic Review, 267*-271.
- Johnson, V. E. (2002). Teacher course evaluations and student grades: An academic tango. *Chance, 15*(3), 9-16.



- Kelly, H. F., Ponton, M. K., & Rovai, A. P. (2007). A comparison of student evaluations of teaching between online and face-to-face courses. *Internet and Higher Education, 10*, 89-101.
- Kuo, Y. C., Walker, A. E., Belland, B. R., & Schroder, K. E. (2013). A predictive study of student satisfaction in online education programs. *International Review of Research in Open & Distance Learning, 14*(1).
- Lalla, M., Frederic, P., & Ferrari, D. (2011). Students' evaluation of teaching effectiveness: Satisfaction and related factors. In *Statistical Methods for the Evaluation of University Systems* (pp. 113-129). Physica-Verlag HD.
- Lewicki, R.J., Barry, B., & Saunders, D.M. (2010). *Negotiation* (International edition). Singapore: McGraw-Hill.
- Loveland, K. A. (2007). Student evaluation of teaching (SET) in web-based classes: Preliminary findings and a call for further research. *Journal of Educators Online, 4*(2), n2.
- Marzano, R. J. (2012). The two purposes of teacher evaluation. *Educational Leadership, 70*(3), 14-19.
- McGreal, R., & Elliott, M. (2008). Technologies of online learning (e-learning). In T. Anderson (Ed.), *Theory and practice of online learning*, 2<sup>nd</sup> ed. (pp. 143-166). Edmonton, AB: AU Press.
- Muñoz Carril, P. C., González Sanmamed, M., & Hernández Sellés, N. (2013). Pedagogical roles and competencies of university teachers practising in the e-learning environment. *International Review of Research in Open & Distance Learning, 14*(3).
- Nargundkar, S., & Shrikhande, M. (2012). An empirical investigation of student evaluations of instruction: The relative importance of factors. *Decision Sciences Journal of Innovative Education, 10*(1), 117-135.
- Northcote, M. T. (2010). Lighting up and transforming online courses: Letting the teacher's personality shine. *Education Papers and Journal Articles*, Paper 33.
- Olivares, O. J. (2003). A conceptual and analytic critique of student ratings of teachers in the USA with implications for teacher effectiveness and student learning. *Teaching in Higher Education, 8*(2), 233-245.
- Paechter, M., Maier, B., & Macher, D. (2010). Students' expectations of, and experiences in e-learning: Their relation to learning achievements and course satisfaction. *Computers & Education, 54*(1), 222-229.

- Rothman, T., Romeo, L., Brennan, M., & Mitchell, D. (2011). Criteria for assessing student satisfaction with online courses. *International Journal for e-Learning Security*, 1(1-2), 27-32.
- Sijtsma, K. (2009). On the use, the misuse, and the very limited usefulness of Cronbach's alpha. *Psychometrika*, 74(1), 107-120.
- Taylor, E. S., & Tyler, J. H. (2012). Can teacher evaluation improve teaching? *Education Next*, 12(4), 10.
- Toch, T., & Rothman, R. (2008). *Rush to judgment: Teacher evaluation in public education*. Washington DC: Education Sector.
- Wade, C. E., Cameron, B. A., Morgan, K., & Williams, K. C. (2011). Are interpersonal relationships necessary for developing trust in online group projects? *Distance Education*, 32(3), 383-396.
- Wiers-Jensen, J., Stensaker, B. R., & Grogard, J. B. (2002). Student satisfaction: Towards an empirical deconstruction of the concept. *Quality in Higher Education*, 8(2), 183-195.

Athabasca University 



## Learning in an Introductory Physics MOOC: All Cohorts Learn Equally, Including an On-Campus Class



Kimberly F Colvin<sup>1</sup>, John Champaign<sup>1</sup>, Alwina Liu<sup>1</sup> (not shown), Qian Zhou<sup>2</sup>, Colin Fredericks<sup>3</sup>, and David E Pritchard<sup>1</sup>

<sup>1</sup>Massachusetts Institute of Technology, USA, <sup>2</sup>Tsinghua University, China, <sup>3</sup>Harvard University, USA

### Abstract

We studied student learning in the MOOC 8.MReV Mechanics ReView, run on the edX.org open source platform. We studied learning in two ways. We administered 13 conceptual questions both before and after instruction, analyzing the results using standard techniques for pre- and posttesting. We also analyzed each week's homework and test questions in the MOOC, including the pre- and posttests, using item response theory (IRT). This determined both an average ability and a relative improvement in ability over the course. The pre- and posttesting showed substantial learning: The students had a normalized gain slightly higher than typical values for a traditional course, but significantly lower than typical values for courses using interactive engagement pedagogy. Importantly, both the normalized gain and the IRT analysis of pre- and posttests showed that learning was the same for different cohorts selected on various criteria: level of education, preparation in math and physics, and overall ability in the course. We found a small positive correlation between relative improvement and prior educational attainment. We also compared homework performance of MIT freshmen taking a reformed on-campus course with the 8.MReV students, finding them to be considerably less skillful than the 8.MReV students.

**Keywords:** MOOC; edX; item response theory; learning gain

## Introduction

The recent release of hundreds of free online courses in MOOCs (massive open online courses) by organizations such as Coursera, edX, and Udacity has been so dramatic that an article in the New York Times proclaimed 2012 the “Year of the MOOC” (Pappano, 2012). These MOOCs, often digitizations of standard, relatively introductory courses from top 50 universities (and especially MIT, Harvard, Berkeley, and Stanford), have provoked multidimensional discussions and special issues of various publications. Nevertheless, few studies have attempted to use MOOC data to address the central question: “is there learning in MOOCs?” Even though documenting learning is a stated goal of some institutions offering MOOCs, there have been few developments in answering this question (Hollands & Tirthali, 2014). In their thorough treatment of the current state of MOOCs and related research, Hollands and Tirthali point out that the lack of consistent data and the voluntary nature of the student participants, who aren’t forced to take a pre- and posttest, for example, has been a roadblock. Hollands and Tirthali did find research on student retention, motivation, and behaviors within a MOOC.

In this paper, we report an initial study of learning in a MOOC, 8.MReV – Mechanics ReView – offered from June 1 to August 27, 2013 on the open source platform edX.org. The course materials were written by the RELATE education group (Research in Learning, Assessing, and Tutoring Effectively, <http://RELATE.MIT.edu>). This is a “second course” in introductory Newtonian Mechanics, designed to help students familiar with the topic at a high school level gain a more expert-like perspective on the subject by learning a categorization scheme for the domain and applying it to work through sophisticated problems that typically involve several physics principles simultaneously (e.g., conservation of both momentum and energy). In addition, we made a concerted effort to attract high school physics teachers to enroll in our course.

We emphasize that measurements of learning in a MOOC are made in an online environment that allows students to consult reference materials both inside the course (e.g., course resources available to students at that point in time) and outside the course (e.g., Google, Wikipedia, or a textbook). This applies to homework as well as to the pre- and posttesting, in contrast to on-campus pre-post testing which is done in a closed-book, no Internet environment. Furthermore, because on-campus assessments are done on paper, students are usually restricted to only one response. In contrast, online students are usually allowed several attempts to get the answer correct and are told whether each response is correct. (We only analyzed the first attempt to make it more similar to a traditional pre- and posttest.) Thus, our definition of learning involves improvement in answering questions *with*, rather than *without*, outside assistance. While this may be a more authentic activity than closed-book examinations, it blurs the comparison of our pre- to posttest results with those from on-campus students.

We used two major approaches to evaluate learning in our MOOC. The first was to give an identical pretest and posttest using the same set of mostly conceptual questions

(Hestenes, Wells, & Swackhamer, 1992). The results were analyzed in terms of the fractional reduction in the number of incorrect answers on the pretest as measured by the posttest. This quantity is referred to as the normalized gain by Hake (1998).

The second approach involved using item response theory (IRT) to analyze the pre- and posttest results as well as the weekly performance of the students. IRT establishes an “ability” for each student based not on total score, but on the difficulty and discrimination of the questions (items) that that student attempted (Meyer & Zhu, 2013). (Discrimination, or slope, is related to the difference in performance of high versus low ability students on that item.) This is especially important in MOOCs where not all students respond to the same set or number of items. We selected cohorts based on education level, preparation in calculus and physics, and on overall skill in the course. The weekly performance of selected cohorts of MOOC students were compared with each other as well as with students in an on-campus course (8.011). The 8.011 IRT analysis was based on homework assignments containing roughly two-thirds of the same questions as the MOOC, also delivered on the same edX platform.

## Data

### Description of Mechanics ReView MOOC: 8.MReV

The 8.MReV course grew from a short Mechanics ReView course that runs at MIT during January for students who received a D in MIT’s large-enrollment fall Mechanics course. The key feature of the ReView course was that faculty and staff interact with two-person groups of students to help them focus on problem solving using our modeling applied to problem solving pedagogy (Pawl, Barrantes, & Pritchard, 2009). This in-class work required preparing the students for class, a need that RELATE met by developing an online eText and assigning pre-class homework at different levels of difficulty. These online materials, augmented by additional problems and weekly quizzes, were offered as a free open online course twice in 2012 using the LON-CAPA platform. Development of the 8.MReV course studied here involved transferring much of this course to the edX platform and supplementing it with more problems (Fredericks et al., 2013). 8.MReV was run in the summer of 2013 with both general and teacher-targeted publicity.

8.MReV includes three basic types of problems: (1) checkpoint questions embedded in the eText for the purpose of guiding the reader and checking for understanding, (2) homework problems at different levels of difficulty (Teodorescu, Pawl, Rayyan, Barrantes, & Pritchard, 2010), and (3) weekly test questions. In the course, the tests are referred to as quizzes, in part, to lower student anxiety. Because there is no final exam the quizzes count heavily toward earning the certificate. Students must obtain at least

60% of the total credit available to earn a certificate; 1,030 students earned certificates in the summer 2013 8.MReV.

The online course included 288 homework items and 115 quiz items. These common questions allowed us to easily compare performance in the two courses. There were three optional units at the end of 8.MReV; because these units were not required to earn a certificate they were not included in this analysis. Although approximately 17,000 people signed-up for 8.MReV, most dropped out with no sign of commitment to the course; only 1500 students were “passing” or on-track to earn a certificate after the second assignment. For the IRT analysis we included only the 1,080 students who attempted more than 50% of the questions in the course, 95% of whom earned certificates. Most of those completing less than 50% of the homework and quiz problems dropped out during the course and did not take the posttest, so their learning could not be measured.

For most homework and quiz items students were allowed multiple attempts at a correct answer: several for multiple-choice items and typically ten attempts for symbolic, free-response items. Informing a student of an incorrect response and allowing additional attempts improves test information and affords a more reliable ability estimate than only using the student’s first response (Attali, 2010). We only modeled up to eight attempts, since very few students used more than eight attempts for quiz and homework items. Most items only needed three or four attempts to accurately model student behavior.

## Methods and Theoretical Framework

### Pre- and Posttesting in the MOOC

A pretest was given before students started working with the materials in 8.MReV. The pretest consisted of 15 questions, three of which came from the Mechanics Baseline Test (Hestenes & Wells, 1992) and four of which came from the Mechanics Reasoning Inventory (Pawl et al., 2011). The posttest contained the same 15 questions plus two multiple-choice items from the Mechanics Baseline Test. See Table 2 in the Appendix for a list of pre- and posttest problems.

The pretest, called Quiz 0, was given at the beginning of the course with this note from the instructor, Professor Pritchard.

### Why Quiz 0?

It may seem strange to start a course with a quiz, but it is important for you to take this quiz, especially because this course is for people with “some knowledge of mechanics.”

It will give us important insight into what you and the class bring to the course in terms of various skills.

It will give you practice taking a quiz (and will not count in your grade).

It will give you an idea of the variety of problem types you’ll experience in this course.

In the future analysis of these data we will be able to give new students guidance on whether they’re ready for this course.

So we hope you will make a conscientious effort to do well on this quiz.

This pretest was then hidden from the students several weeks into the course, so that they could neither review these questions nor refer to them when answering the posttest. The posttest questions were contained in the last two weekly tests, although some of the better students had amassed sufficient points for a certificate and didn’t take these tests. Of the 3,899 students who attempted at least one item on the pretest, the mean number of items attempted was 10.0; of the 1,117 students who attempted at least one item on the posttest, the mean number of items attempted was 8.2.

These 15 questions weighed conceptual knowledge more heavily than algebraic ability. With the exception of two questions requiring symbolic entries, all of the items were multiple choice questions. Two questions were given only on the posttest as part of a study on the residual effects of student memory on pre- and posttesting, and are not included in this analysis.

### Item Response Theory (IRT)

IRT judges student ability by taking into account a student’s specific performance on each item. An item is a single question that demands a unique student response that generally can be judged right or wrong. We considered each item separately, even where two items are from the same multi-part problem. IRT stands in contrast to classical test theory where the unit of analysis is the entire test, usually scored as the total number of items correct (Mellenbergh, 2011; Crocker & Algina, 1986).

An advantage of IRT is that it gives accurate estimates of students’ abilities even when students have not taken the same set of items. This is particularly important in this study because students do not need to complete all of the homework and quiz questions in 8.MReV or 8.011 to pass the course, so students do not generally attempt all available



problems. IRT is also preferable because it extracts more information than simply using the total number of items correct by accounting for the difficulty of each item and each item's ability to discriminate between students of higher and lower abilities (Hambleton, Swaminathan, & Rogers, 1991).

IRT relates a student's performance on a set of items to the student's ability (skill) on an underlying trait or proficiency, referred to as  $s$ , in this study. Many IRT models exist; all contain at least one parameter related to the item and at least one parameter related to the student (Hambleton et al., 1991). IRT allows students and items to be placed along the same proficiency scale, where higher numbers indicate more difficult items and more proficient students. IRT's 2-parameter logistic model (2PL) is a common example:

$$P_i(s) = \frac{e^{a_i(s-d_i)}}{1 + e^{a_i(s-d_i)}} \quad (\text{Hambleton et al., 1991}),$$

where  $a_i$  and  $d_i$  are the parameters for item  $i$  and  $s$  is the examinee's ability, also referred to as proficiency or ability.  $P_i(s)$  is the probability that an examinee with ability  $s$  will correctly respond to item  $i$ . The  $d$ -parameter is the item difficulty parameter. The  $a$ -parameter is the discrimination parameter and can be thought of as the correlation between performance on an item and performance on the test or complete set of items as a whole. An assumption of IRT is unidimensionality, that there is only one dimension or factor affecting the likelihood of a student's correct response, namely, the student's underlying ability. If unidimensionality holds, the probability of correctly answering an item should increase as the level of ability increases.

IRT is sophisticated "grading with respect to a curve": Student abilities are constrained in an IRT analysis to have a mean of 0 and a standard deviation of 1. Thus a time series of IRT scores of a student in a class that is learning does not show absolute learning (as measured above by pre-post testing), but rather improvement relative to "class average." However, weekly IRT ability is a good measure for comparing two different cohorts undergoing two different pedagogical treatments, or even different cohorts of students undergoing the same pedagogical treatment, for example, to investigate the effects of demographics or study patterns on relative learning rates.

## Multiple Attempts

To incorporate multiple attempts (IRT), we modeled student ability with an extension of item response theory that accounts for ordered response categories, not just binary (right or wrong) responses. Samejima's graded response model (1997) is an extension of IRT's 2-parameter-logistic model described earlier and was developed to model ordered scores or responses to an item. This could be an essay scored with a point-based rubric, for example, or the number of correct steps an examinee performs in an algebra problem with a clear set of steps required for a complete response. As suggested by Attali (2010), modeling the number of attempts a student needs before a correct



response is analogous to these ordered categories, with the fewer attempts required indicating more ability.

The graded response model (GRM) models the likelihood that an examinee with a given ability will provide a response in each category. In this study, the categories correspond to the attempt with a correct response. The probability of a correct answer on the second attempt is modeled as the product of the probabilities of correct responses on the third, fourth, and fifth attempts and the probability of an incorrect response on the first attempt. The GRM assumes that a positive response in category  $n$  implies positive responses in all lower, that is, easier categories. This assumption is reasonable in this application where it would be reasonable to assume that an examinee who correctly responds to an item on the 2<sup>nd</sup> attempt (and is so informed in real time) would correctly answer on the third, fourth, and fifth attempts if indeed they were made. The item parameters and student ability estimates are calculated using maximum likelihood estimation via the psychometric software MULTILOG (Thissen, 1991).

## Item Calibration

Using the graded response model, we initially calibrated quiz and homework items separately. We first looked for items not fitting the model, meaning that for a particular item students with less ability were more likely to respond correctly to the item on an earlier attempt than strong students, for example. These items prevented the model from converging such that it was impossible to calibrate the other items. We identified 7 quiz and 32 homework out of 138 and 256, respectively, for removal from the IRT analysis. Because there were so many items in total, this had little to no effect on the final estimates of student ability. Once a decision was made about which items to remove, all homework and quiz items were calibrated simultaneously using the combined student pool from 8.MReV and 8.011. The item parameters from this joint calibration were then used to obtain ability estimates for each student's weekly homework and quiz performances. We calculated each student's ability on each weekly topic. The distribution of student abilities for each week was re-centered such that the mean ability for each week was zero, allowing a week-by-week comparison of changes in ability.

## Pre- and Posttest Results

### Pre- and Posttest Analysis with Normalized Gain

To assess whether students exhibited learning in the MOOC, we analyzed the pre- and posttest results in two different ways: using traditional pre- and posttesting procedures (Hake, 1998) involving normalized gain and using IRT. Item response theory can judge

the ability of students from different subsets of the items, allowing us to include a larger fraction of our students in the pre-post comparison. To effectively compare pre- and posttest scores using the normalized gain technique, students need to have attempted the same set of questions on both tests, which limits the number of students in each cohort. In part to increase the sample size, the pre-post test analysis was performed on two subsets of questions: (1) six questions involving force and motion that could be compared with Hake's study (1998), (2) five purely conceptual questions on more advanced topics, and (3) seven questions consisting of these five plus two questions requiring symbolic responses rather than multiple choice. There were 419 students who attempted all six questions in subset 1 on both the pre- and posttests, 343 students who attempted all five subset 2 questions on both the pre- and posttests, and 176 students for subset 3. Data for these three question sets are presented in Hake's format in Figures 1-3 where the various cohorts are analyzed independently.

The 6,000-student study by Hake (1998), which investigated about 60 different classes ranging from high school to top quality colleges, showed that the normalized gain is typically 0.23 for traditionally taught courses, but increases to about 0.48 for interactively taught courses. The clearest comparison with Hake's numbers is subset 1, questions involving force and motion, as shown in Figure 1.

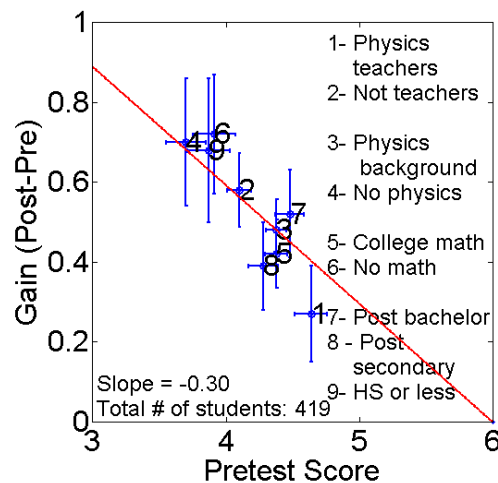

*Figure 1.* The negative slope of the red line, constrained to go through the point (6,0), indicates the normalized gain that best fits the 419 students who answered all 6 force-related items on both pre and post tests. The mean pretest and gain scores, with standard errors, are also shown for various cohorts. “No math” indicates the cohort of students without college-level calculus.

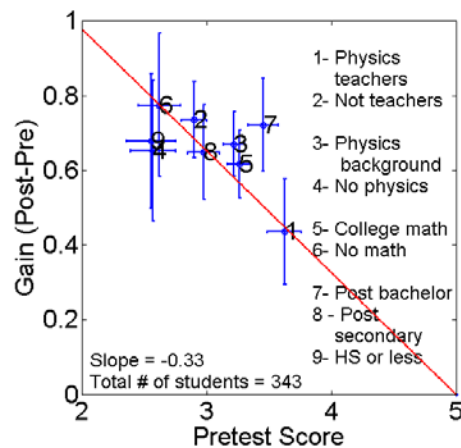

*Figure 2.* The negative slope of the red line, constrained to go through the point (5,0), indicates the normalized gain that best fits the 343 students who answered all 5 non-force-related items on both pre and post tests. The mean pretest and gain scores, with standard errors, are also shown for various cohorts.

Thus we have observed learning as measured by normalized gain that is between these limits. While both of our gains, 0.30 and 0.33 ( $\pm 0.02$ ), are closer to the gains Hake reported for traditional on-campus courses, they lie above *all* of the 14 traditional classes studied by Hake, suggesting that our students learn conceptual topics slightly better than in a traditional, lecture-based, class. This comparison is blunted by the fact that typically 19% of the first responses to a question were *preceded by reference* to in-course resources, about a 1:1 ratio with the percentage of wrong answers. (Previously we found this ratio to be 1:3 in spite of a penalty that served to discourage students from giving wrong answers [Lee, Palazzo, Warnakulasooriya, & Pritchard, 2008].) More investigation shows several differences between student behavior on pre and posttest. Good comparisons of MOOCs and traditional courses with pre- and posttests must await a MOOC testing platform that prevents students from visiting other sites or materials before making their first response.

It is noteworthy that constraining the fit to pass through zero for a perfect score on the pretest does not add significantly to the uncertainty and thus is consistent with the data. We have termed such a situation one of “pure learning” (Pritchard, Lee, & Bao, 2008), which means that the data are consistent with the hypothesis that the number of initially incorrect answers given by each student (or each cohort) is reduced by a fraction equal to the normalized gain. The fact that no cohorts lie significantly below or above the best fit line in Figure 2 and Figure 3 should allay concerns that less well prepared students cannot learn in MOOCs.

Our concept test spanned a wider range of topics than Hake’s study, which concerned topics covered in the first four weeks of 8.MReV. Furthermore, the questions on the Force Concept Inventory are narrow in scope, unlike the non-force questions in our pre-

and posttests that required analyzing answers, providing reasons for conceptual judgments, and finding the mistake in a given solution. However, the normalized gain seems insensitive to the particular questions used. Indeed, Hake's study reached its conclusions by amalgamating results from both the Force Concept Inventory and the Mechanics Baseline Test (which had some non-conceptual problems requiring choice among numerical answers and some questions on topics beyond the FCI). This insensitivity is further emphasized by the similarity of our results for force questions and all other questions (see Figures 1 and 2).

## Relative Performance of Various Cohorts

The large enrollment and diverse demographics of the MOOC student body allow us to separately analyze and compare the relative learning of various cohorts of students in 8.MReV. We have formed and analyzed cohorts according to highest degree attained, academic preparation, and average ability in the course. Specifically, background in introductory physics and first semester calculus were used for academic preparation.

We have found one group that has a significantly higher normalized gain than all the rest. It is those 176 students who answered the two questions (12 and 13) on the pre and posttests that required a symbolic answer. Although their gains on those two questions were both less than 0.3, their gains on the other five non-force questions were sufficiently high that, for the seven questions, they had a normalized gain of 0.41 (+/- 0.03), as shown in Figure 3. The group has members from all previously mentioned cohorts in it, and is not distinguished by any obvious demographics.

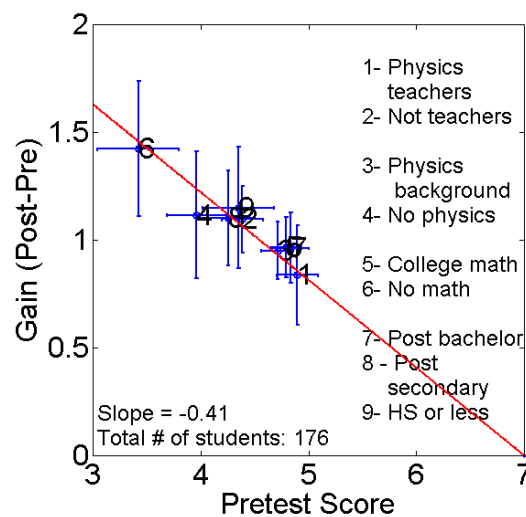

*Figure 3.* The negative slope of the red line, constrained to go through the point (7,0), indicates the normalized gain that best fits the 176 students who answered five non-force-related and two symbolic items on both pre and posttests. The mean pretest and gain scores, with standard errors, are also shown for various cohorts.

Figures 1-3, showing the normalized gain of the students in 8.MReV, display the pretest score and learning gains of the various cohorts just listed. Whether we look at gains on force-related concepts, non-force-related concepts, or examine the subset of each cohort that attempted the questions requiring the use of the symbolic answer interface in edX, we see no cohorts lying significantly below or above the normalized gain lines that fits all students in that sample. This certainly should allay concerns that less well prepared students cannot learn in MOOCs. In fact, the actual score improvement (gain) is *higher* for students with lower scores on the pretest (see Figures 1-3).

## Pre- and Posttest Analysis with IRT

The pre- and posttest items occurred twice in the course, but the calibration process (to find their difficulty and discrimination) assumed they occur only once. For calibration we only used the responses to the posttest items, not the pretest, because the knowledge of the students at pretest would reflect details of the obviously highly variable previous instruction of our students. The resulting IRT discrimination and difficulty estimates were then used to calculate initial ability estimates for the students based on the pretest items.

Unlike the normalized gain procedures, because IRT can compare students who have taken different sets of items, we did not have to exclude as many students for the comparison, as we did with the normalized gain analysis. However, to obtain a reasonable estimate of a student's IRT score on the pretest and posttest, we only included the 578 students who had responded to at least seven pre- and eight posttest items. The gain in IRT score from the pretest to the posttest was 0.41 (standard error = 0.03) and independent of the average ability of the students, as seen in Figure 4.

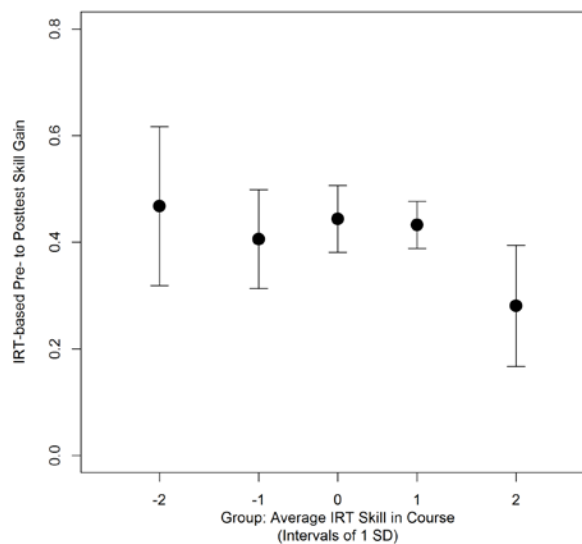

*Figure 4.* The IRT-based pre- to posttest gain for students grouped by their overall ability (skill) in the course.

## Comparing MOOC and On-Campus Class Using Online Homework

Students in 8.MReV answer more homework questions each week than on the pre- or posttest. These responses therefore permit us to find the weekly IRT abilities of the students with reasonable statistical error. These give us an ability to quantify the improvement (or worsening) of the ability of students and cohorts over the semester. Ideally this will lead to insights about the learning habits and resource usage of students who improve relative to those who do not. This also allows us to measure the on-campus students in 8.011 (spring of 2013) on the scale of the 8.MReV MOOC students by using the online homework done by both groups. Of the 403 items, in the 8.MReV MOOC, 253 items had previously been given to the on-campus 8.011 students via the edX platform. The details of homework administration for both groups was highly similar: Both groups were allowed multiple attempts, both used the same platform, and both were done in an open-book, open Internet environment. Before we compare the overall ability and the week-by-week evolution of the abilities of the students in various cohorts of 8.MReV, including the 8.011 students as an additional cohort, we briefly describe the 8.011 course.

### Description of On-Campus Course: 8.011

The on-campus course, 8.011, is the spring version of Introductory Newtonian Mechanics at MIT. This course, together with the subsequent Electricity and Magnetism course, is required of all MIT graduates, and most take it in their first semester. Students who earn less than a C in the fall Mechanics course are required to retake the course before moving on to Electricity and Magnetism; these students make up about 80% of the population of 8.011. In spring 2013, there were 47 students in 8.011, the first time the online segment of the course was run on the edX platform rather than on LON-CAPA. Of these 47 students, 35 attempted more than half of the online problems. Data from these 35 students were used in this study.

The course is designed primarily to help students review their understanding of the various topics in mechanics, but especially to help them organize this knowledge under five core models, which subsequently enables them to decide which core models apply to a particular problem. The pedagogy used is modeling applied to problem solving (Pawl et al., 2009). The first nine weeks of the course review the core topics and concepts in mechanics, and the subsequent six weeks involve topics with problems that require using several physics laws at once.

### Comparative Abilities and Weekly Evolution of Cohorts

Figure 5 shows the distribution of student abilities on the items common between the two courses. The top-performing cohort, physics teachers, is highlighted. The teachers scored about half of a standard deviation above average, with a very few in the low-ability tail. The on-campus 8.011 students' ability averaged about 1.0 standard deviation

below the average in 8.MReV. In retrospect, this may not be surprising as the average 8.MReV student is far better educated, older, and is not juggling three or four other MIT courses.

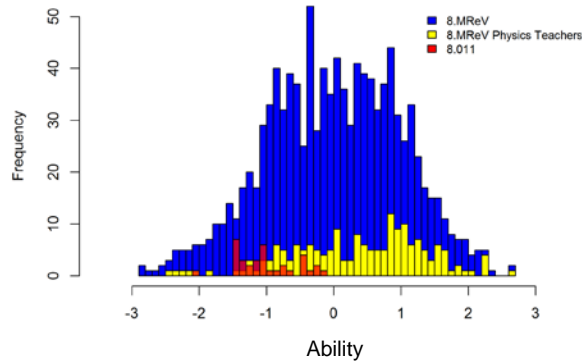

*Figure 5.* The distribution of abilities in 8.MReV overall, the teacher cohort in 8.MReV (yellow), and the on-campus 8.011 students (red).

Table 1 compares the relative abilities of various cohorts of students in 8.MReV with each other and with the on-campus students. We include cohorts based on their levels of education and status as 8.011 on-campus students or physics teachers. The relative improvement is the difference in a student's beginning and ending ability in the class as defined by a line of best fit to the student's weekly ability based on homework and quiz items. The relative improvement of a cohort is the average of the individual improvements.

Table 1

*Average Ability of Various Cohorts*

Cohort	% of 8.MReV	Average ability in 8.MReV			Relative improvement (SE)
		Mean	Standard deviation	Standard error	
PhD	8	0.67	0.93	.10	0.16 (0.06)
Masters	19	0.26	0.91	.06	-0.06 (0.05)
College	29	-0.08	0.99	.06	-0.11 (0.04)
High school	11	-0.20	0.93	.07	-0.11 (0.06)
Less than HS	6	-0.05	0.84	.10	-0.21 (0.10)
No response	23	0.02	1.04	.07	0.01 (0.07)
Physics teachers	17	0.39	0.97	.07	0.00 (0.05)
8.011 students	3	-1.05	0.50	.08	-

*Note.* Degree listed is highest degree attained. For example, “High School” refers to students who have obtained a high school diploma and may be enrolled in college.

The most salient feature of Table 1 is that the magnitude of the relative improvement, or change in relative ability, is small for all cohorts. A change of 0.2 would be less than the change from a B to a B+, for example. There is a small positive correlation between relative improvement and increased educational attainment. This might reflect that obtaining more education either develops or selects for greater learning skills. On the other hand, students with more education may, on average, have forgotten more of the physics they learned at a younger age so that they were able to relearn the material faster than younger students were able to learn it.

The graph in Figure 6 shows the weekly IRT abilities of several cohorts of 8.MReV students compared with the 8.011 on-campus students. Each set of weekly abilities was forced to have a mean of 0 and a standard deviation of 1. Therefore, maintaining the same ability across the course is not an indication of “not learning,” but rather of not changing your ability relative to the class average. None of the cohorts shown in Figure 6 had a statistically significant relative improvement over the course. In particular, there was no evidence that cohorts with low initial ability learned less than the other cohorts.



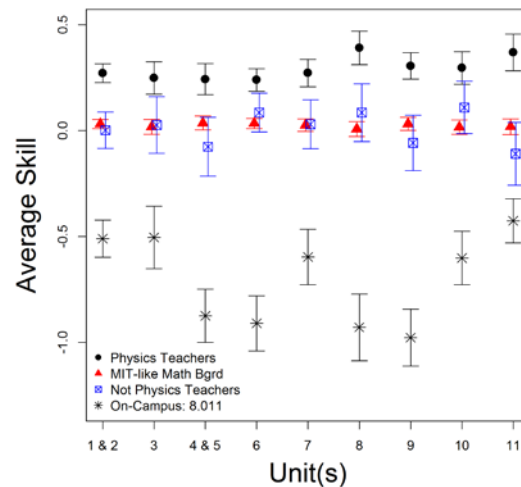

*Figure 6.* Weekly performance of various cohorts in 8.MReV compared with on-campus students in 8.011. Note: MIT-like Math Background refers to students with at least one-semester of calculus.

## Comparison of On-Campus and MOOC Relative Ability

First, we address the question of whether the on-campus students measurably benefit from this environment. On-campus students, unlike the MOOC participants, benefitted from the following: four hours of instruction in which staff interacted with small groups of students (a flipped classroom) each week, staff office hours, helpful fellow students, available physics tutors, and the MIT library. Although the online students had lively discussions on many of the discussion boards that followed each eText page and problem and were required to do about 30% more problems (including more problems in the online tests than the on-campus students did in their weekly in-class tests), we still thought it likely that the on-campus students would show an increase in week-by-week ability relative to the online students. Clearly, this is not the case. The fact that most of the on-campus students had started the fall semester mechanics course (8.01) in 2012, but dropped out or completed it with a failing grade may have given them extra training on the material in the first several units. Note also that the on-campus course extended four weeks beyond the end of the material covered in 8.MReV and included topics like the harmonic oscillator, planetary orbits, a review of important procedures, and a general review of all material. But the bottom line remains: In spite of the extra instruction that the on-campus students had, Figure 6 shows no evidence of positive, weekly relative improvement of our on-campus students compared with our online students.

## Summary and Conclusions

We have studied conceptual learning in a MOOC by analyzing the results of pre- and posttesting in two ways: normalized gain and item response theory (IRT). Both methods show unequivocal evidence of learning. The amount of learning, normalized gain,  $0.31 \pm 0.02$ , was higher than in any of the 14 traditional (i.e., lecture-based) courses studied by Hake 1998, but was in the lowest decile of courses whose classes included “interactive engagement” activities.

The diversity and large sample size of the MOOC enabled us to separate the learning of various cohorts. We divided the sample into cohorts based on educational level, amount of preparation in mathematics, in physics, and by whether they were teachers. None of our nine cohorts had normalized gain that differed significantly from 0.31. This applied to questions involving both force and motion (the most frequently measured concepts in other studies) and all other topics taken together.

An advantage of comparisons of cohorts within our MOOC is that concerns about the MOOCs selecting only highly motivated students, or about the special nature of pre- and posttesting in our online environment, apply equally to all of the students in the MOOC. Thus, comparisons of various cohorts within the same MOOC give reasonably definitive results.

In addition, we have compared the weekly IRT abilities of students in a reformed on-campus course incorporating a flipped classroom relative to those of the 8.MReV class and several cohorts of its students. There is certainly no evidence that the on-campus students’ four hours of intimate contact with teaching staff increased their relative ability over the term.

Now that we can measure the learning in our MOOC, we are in a position to study what correlates with it. Indeed we have made a preliminary investigation (Champaign et al., 2014) finding significant positive correlations with time spent on several different resources, but with little differentiation between them. A second factor that might affect learning is study patterns; for example, we found dramatically different patterns of resource use when students did homework versus exams (Seaton, Bergner, Chuang, Mitros, & Pritchard, 2014). This raises the question of whether students following these (or other) patterns will show more or less learning.

Another interesting area for future research is comparisons with other introductory physics MOOCs that have done pre-post testing to measure conceptual learning. Preliminary results from the Georgia Institute of Technology MOOC, which emphasizes students analyzing videos, show significantly less gain than we find here (G. Schatz, personal communication, June 19, 2014), whereas a video-based MOOC at the University of Colorado, which emphasizes conceptual learning, has significantly more gain than we see here, at least on force and motion (M. Dubson, personal communication, June 20, 2014). Given the different demographics of those registering,

the different objectives of each course, and the significantly smaller percentage of certificate earners in these other MOOCs, direct comparisons will be challenging.

In the future we can sharpen the results of pre- and posttesting by administering the same questions to on-campus students and those in the MOOC, constrained by the concern that too much pretesting in the MOOC may make some students withdraw because they feel like guinea-pigs.

It is also important to note the many gross differences between 8.MReV and on-campus education. Our self-selected online students are interested in learning, considerably older, and generally have many more years of college education than the on-campus freshmen with whom they have been compared. The on-campus students are taking a required course that most have failed to pass in a previous attempt. Moreover, there are more dropouts in the online course (but over 50% of students making a serious attempt at the second weekly test received certificates) and these dropouts may well be students learning less than those who remained. The pre- and posttest analysis is further blurred by the fact that the MOOC students could consult resources before answering, and, in fact, did consult within course resources significantly more during the posttest than in the pretest.

In summary, our MOOC produced significant and roughly equal *learning* for all of the cohorts differentiated along several axes that strongly influence their overall *ability*:

- students with high school or less education versus those with advanced college degrees;
- students lacking good preparation in math and physics – both obviously important for success in this course – versus those with good preparation; and
- students who display low ability versus high ability on the pretest.

In addition, we find a small improvement, relative to the overall class, for cohorts with a more formal education.

## Acknowledgments

We acknowledge support from a Google Faculty Award, MIT, and NSF. We thank Yoav Bergner and Fiona Hollands for their suggestions and thoughtful comments on this manuscript. We thank Yoav Bergner and Daniel Seaton for work on analysis software used for these data.

## References

- Attali, Y. (2010). Immediate feedback and opportunity to revise answers: Application of a Graded Response IRT Model. *Applied Psychological Measurement*, 35(6), 472–479. doi:10.1177/0146621610381755
- Crocker, L. M., & Algina, J. (1986). *Introduction to classical and modern test theory*. New York: Holt, Rinehart, and Winston.
- Fredericks, C., Rayyan, S., Teodorescu, R., Balint, T., Seaton, D., & Pritchard, D. E. P. (2013). *From flipped to open instruction: The Mechanics Online Course*. A paper presented at the Sixth International Conference of MIT's Learning International Networks Consortium.
- Hake, R. R. (1998). Interactive-engagement vs traditional methods: A six-thousand-student survey of mechanics test data for introductory physics courses. *American Journal of Physics*, 66(1), 64-74.
- Hambleton, R. K., Swaminathan, H., & Rogers, H. J. (1991). *Fundamentals of item response theory*. Newbury Park, CA: Sage Publications.
- Hestenes, D. & Wells, M. (1992). A mechanics baseline test. *The Physics Teacher*, 30, 159-165.
- Hestenes, D. Wells, M., & Swackhamer, G. (1992). Force concept inventory. *The Physics Teacher*, 30, 141-158.
- Hollands, F. M. & Tirthali, D. (May, 2014). *MOOCs: Expectations and reality. Full report*. Center for Benefit-Cost Studies of Education, Teachers College Columbia University. Retrieved from [http://cbcse.org/wordpress/wp-content/uploads/2014/05/MOOCs\\_Expectations\\_and\\_Reality.pdf](http://cbcse.org/wordpress/wp-content/uploads/2014/05/MOOCs_Expectations_and_Reality.pdf)
- Lee, Y.-J., Palazzo, D. J., Warnakulasooriya, R., & Pritchard, D. E. (2008). Measuring student learning with item response theory. *Physical Review Special Topics: Physics Education Research*, 4, 010102, DOI: 10.1103/PhysRevSTPER.4.010102
- Mellenbergh, G. J. (2011). *A conceptual introduction to psychometrics: Development, analysis, and application of psychological and educational tests*. The Hague, Netherlands: Eleven International.
- Meyer, J. P., & Zhu, S. (2013). Fair and equitable measurement of student learning in MOOCs: An introduction to item response theory, scale linking, and score equating. *Research and Practice in Assessment*, 8, 26-39.
- Pappano, L. (2012, November 2). The year of the MOOC. *The New York Times*.

- Pawl, A., Barrantes, A., & Pritchard, D. (2009). Modeling applied to problem solving. *Proceedings of the 2009 Physics Education Research Conference*, 51-54.
- Pawl, A., Barrantes, A., Cardamone, C., Rayyan, S. & Pritchard, D. E. (2011). Development of a mechanics reasoning inventory. *Proceedings of the 2011 Physics Education Research Conference*, 1413, 287-290.
- Pritchard, D. E., Lee, Y. J., & Bao, L. (2008). Mathematical learning models that depend on prior knowledge and instructional strategies. *Physical Review Special Topics-Physics Education Research*, 4(1), 010109.
- Samejima, F. (1997). Graded response model. In W. J. van der Linden & R. K. Hambleton (Eds.), *Handbook of modern item response theory* (pp. 85-100). New York: Springer.
- Seaton, D. T., Bergern, Y, Chuang, I, Mitros, P, & Pritchard, D. E. (2014). Who does what in a massive open online course? *Communications of the ACM*, 57(4), 58-65.
- Teodorescu, R., Pawl, A., Rayyan, S., Barrantes, A., & Pritchard, D. (2010). Toward an integrated online learning environment. *Proceedings of the 2010 Physics Education Research Conference*, 1289, 321-324.
- Thissen, D. (1991). MULTILOG: Multiple category item analysis and test scoring using item response theory [Computer software]. Chicago: Scientific Software International.

## Appendix

Table 2

*Pre- and Posttest Problems*

	Problem summary	% Correct		Normalized gain	Attempts allowed
		Pre	Post		
1	identify correct free body diagram, forces labeled	94	93	-0.13	4
2	identify correct free body diagram, forces not labeled	50	55	0.10	4
3	identify forces in free body diagram	63	68	0.15	4
4	answer sense-making: block on ramp attached to massive pulley	57	84	0.63	2
5	inelastic collision, find the error in given solution	46	56	0.19	1
6	explain answer to question above	62	74	0.33	2
7	pendulum swings down, collides inelastically. decomposition	75	67	-0.30	1
8	justify answer to question above	63	64	0.03	2
9	find force of rope pulling elevator at constant speed	76	85	0.40	2
10	direction of acceleration for block at bottom of circular ramp	44	68	0.43	3
11	direction of acceleration after block leaves ramp	84	91	0.43	3
12	find maximum elongation of mass on vertical spring after sudden release	58	65	0.16	3
13	heat generated after above mass comes to rest	55	61	0.13	3
14	find scale reading for mass in elevator given elevator's change in velocity over time interval	NA	63	NA	2
15	find maximum speed of cylinder on turntable, given $m$ , $\mu$ , $r$	NA	81	NA	2
16	find maximum stretch of spring given initial position and velocity of given mass	48	68	0.38	10
17	moving mass approaches fixed mass with mutual attraction; find position where they collide given time of collision (use dynamics of center of mass)	27	44	0.23	10

*Note.* Percent correct based only on those students who attempted the problem.

The first 11 questions on the pre- and posttests are all multiple choice questions, generally involving conceptual issues rather than computations. These may be considered as conceptual tests, like the pioneering Force Concept Inventory (FCI) (Hake et al., 1992). The physics education research community has long compared the effectiveness of different pedagogies by the normalized gain on concept tests, that is, the fractional reduction in the number of incorrect responses to the questions on the posttest relative to the number of incorrect responses on the pretest.

Athabasca University 



# Analytics to Literacies: The Development of a Learning Analytics Framework for Multiliteracies Assessment

Shane Dawson<sup>1</sup> and George Siemens<sup>2</sup>

<sup>1</sup>University of South Australia, Australia, <sup>2</sup>University of Texas-Arlington, USA

## Abstract

The rapid advances in information and communication technologies, coupled with increased access to information and the formation of global communities, have resulted in interest among researchers and academics to revise educational practice to move beyond traditional 'literacy' skills towards an enhanced set of "multiliteracies" or "new media literacies". Measuring the literacy of a population, in the light of its linkage to individual and community wealth and wellbeing, is essential to determining the impact of compulsory education. The opportunity now is to develop tools to assess individual and societal attainment of these new literacies. Drawing on the work of Jenkins and colleagues (2006) and notions of a participatory culture, this paper proposes a conceptual framework for how learning analytics can assist in measuring individual achievement of multiliteracies and how this evaluative process can be scaled to provide an institutional perspective of the educational progress in fostering these fundamental skills.

**Keywords:** Learning analytics; multiliteracies



## Introduction

The development of a literate population is one of the most recognizable goals of public education. Central to this goal has been defining what counts as literacy for contemporary society. In the more traditional sense, literacy was, and continues to be, deeply enmeshed with the written word (Kress, 2003). As Jim Dator (2005) argues, “seldom has a technology been the subject of more worship than the word is in literate cultures” (p. 202). This emphasis on the written word stems from the perceived relationship between basic literacy skills and future economic prospects. Even in the industrial age, the cultivation of a literate population (reading, writing and basic arithmetic) was viewed as an essential ingredient for achieving democracy, economic growth, and social stability (Kalman, 2008). In essence, an individual’s future social and economic prosperity was related to their capacity to read and write (Leadbeater & Wong, 2009). It is little wonder then that literacies have continued to be so intimately linked to economic benefits, such as higher socio-economic status, increased job opportunities, and increased wealth within the community (UNESCO Education Sector, 2004).

Basic literacies are as relevant today in the information age as they were previously, especially given that the Internet and mobile devices remain as heavily text-based technologies (Greenhow & Robelia, 2009; Warschauer, 2007). However, the pervasiveness and pace of change associated with new forms of media and the contexts in which they are applied places additional expectations on what it now means to be “literate” (Anstey & Bull, 2006; Huijser, 2006). That is, the expectation now exists that individuals have at their disposal a diverse set of skills and cultural competencies necessary to navigate the various forms of digital communication and participation in a global society. While not understating the continued importance for reading, writing, and numeracy skills, an emphasis placed solely on those ‘basics’ ignores the broader changes that have occurred in the cultural, social, and economic landscape and the speed of access to technologies and information that are now prevalent in today’s society (Kalantzis, Cope, & Harvey, 2003). A society that is increasingly reliant on technology for information access and communication alongside the globalization of information requires its citizens to effectively utilize a greatly expanded skill set to encompass cultural and new media competencies as well as a recognition of the various contexts in which they are applied (Coiro, Knobel, Lankshear, & Leu, 2014).

If an expanded form of literacy, multiliteracies, is the key to individual and community wealth and wellbeing within a society, then it is crucial to the value of education to establish measures regarding how well students in the education system are mastering these fundamentals. Not only is there a need to assess individual students on their progress and mastery of skills in multiliteracy, but it is important to measure systemic progress and attainment of multiliteracies of the education system and society as a whole. Measurement of the literacy of a population, in the light of its linkage to

individual and community wealth and wellbeing, is an essential and fundamental measure of the success of formal education.

This paper begins with an examination of multiliteracies in order to create a defined set of skills that can be considered essential literacies for today's society. Following this review, the potential assessment and learning activity artifacts that might be generated in the process of learning multiliteracies are discussed. The trend for increasing adoption of online and blended modes of learning continues unabated at a global level and as such there are now unprecedented levels of trace data that can be harnessed to inform teaching and learning practice. Given the potential artifacts that learners generate in these online learning environments, this paper proposes a conceptual framework for using learning analytics to measure the development of multiliteracies across a group of learners. This paper outlines a framework for moving analytics from what has been previously described as the "low hanging fruit" <sup>1</sup> up the ladder to richer and more complex multi-dimensional analytics in education. The conceptual framework proposed in this paper emphasizes the identification of key multiliteracies based on a review of frameworks created by media scholars and then suggests possible data sources and analytics strategies that will enable a means of measuring and determining the impact of those literacies. Validation of the learning analytics/multiliteracy framework is beyond the scope of this paper but it is expected that detailing the relationship between literacies, artefacts, and analytics techniques will lead to empirical work to test, validate, and revise the frameworks offered by media scholars.

## Multiliteracies

Recognition of the dramatically changing nature of what it means to be literate in the so-called 'information age' has seen the rise of discussions within educational research around the importance of students developing "multiliteracy" skills (I. Brown, Lockyer, & Caputi, 2010; Cope & Kalantzis, 2000a; Haythornthwaite & Andrews, 2011). As first described by the New London Group (1996), the term multiliteracies extends the scope of traditional literacy to include the diversity of media and modes of communication that are now available to learners and the varying contexts in which they are utilized. In discussing the genesis of the term multiliteracies, Gee (2009) noted that literacy "needed to be viewed as embedded in multiple socially and culturally constructed practices, not seen as a uniform set of mental abilities or processes" (p. 196). In essence, the New London Group (NLG) challenged the existing singular view of the term literacy recognizing the multiplicity of communications available to learners both as producers and consumers and the increasing cultural and linguistic diversity that is prevalent today (Cope & Kalantzis, 2000b). Simply put, new technologies are changing the way we

---

<sup>1</sup> Learning and Knowledge Analytics (2011): Knewton – the future of education?  
<http://www.learninganalytics.net/?p=126>

communicate and interact. As such, the term multiliteracies is often used interchangeably with new literacies, digital literacies, or media literacies.

Since establishing “a pedagogy of multiliteracies” (Cope & Kalantzis, 2000b; New London Group, 1996), much conceptual and theoretical work has been undertaken in the literacy field (e.g., Gee, 2007; Kress, 2003; Lankshear & Knobel, 2003; Muspratt, Luke, & Freebody, 1998). The goal of this paper is to bring a new perspective of how to assess and evaluate the development of new literacies and the pedagogical activities that underpin such characteristics and skills, rather than to establish an authoritative definition or review of literacies.

## A Participatory Culture

While further theorizing of the changing nature of and intersection between literacy, learning, and digitality needs to continue, there is acceptance that multiliteracies involve an increasing set of social skills that draw upon an ever expanding set of technologies, media, and discourses (Gee, 2007; Unsworth, 2001). In this context, viewing literacy through a sociocultural lens encompasses the fundamentals of literacy (e.g., reading, writing and meaning making) within embedded social practice (Lankshear & Knobel, 2007). Henry Jenkins (2006) emphasizes this point in noting that “the new literacies almost all involve social skills developed through collaboration and networking” (p. 4).

The complexity of the information, media, and technology environment that learners draw on in their day to day academic and social activities, as well as the types of skills necessary to be productive community members, is captured in Jenkins, et al.’s (2006) notion of a participatory culture. Jenkins and colleagues describe a participatory culture as one with “relatively low barriers to artistic expression and civic engagement, strong support for creating and sharing creations, and some type of informal mentorship whereby experienced participants pass along knowledge to novices” (p. xi). Educational engagement in this form of practice is strongly aligned with more Vygotskian-influenced approaches to learning such as social learning (J. S. Brown & Adler, 2008), game-based learning (Gee, 2007), self-directed learning (Garrison, 1997), and communities of practice (Lave & Wenger, 1991). The US Department of Education report, *Transforming American Education: Learning Powered by Technology* (2010), echoes this sentiment in noting that contemporary education practice must embrace technology mediated modes of learning for establishing access to diverse resources and connections to the broader learning community – a community that extends beyond the classroom and beyond national borders. Advocacy for these learning orientations is grounded in the view that knowledge is constructed through an individual’s interactions with the broader social group. To be productive participants in these social learning approaches requires not only the basic literacies but what Jenkins describes as “new media literacies” (Jenkins et al., 2006) or “cultural competencies and social skills” (p. xiii) necessary to be productive participatory citizens.

The competencies and skills necessary for a participatory culture include networking, collaboration, creativity, citizenship, and communication within a multiplicity of modes and mediums. Table 1 outlines Jenkins et al.'s (2006) new media literacies stressing the transition of literacy practice from individual to community. Simply put, for 21<sup>st</sup> century education these skills and attributes are considered to be the 'new basics'. As such, the plurality of these new literacies also calls for new and diverse forms of assessment to be developed and implemented within the formal education context.

Table 1

*Overview of New Media Literacies (Jenkins et al., 2006)*

New media literacies	Description
Play	Capacity to experiment with one's surroundings as a form of problem-solving.
Performance	Ability to adopt alternative identities for improvisation and discovery.
Simulation	Ability to interpret and construct dynamic models of real-world processes.
Appropriation	Ability to meaningfully sample and remix media content
Multitasking	Ability to scan one's environment and shift focus as needed to salient details.
Distributed cognition	Ability to interact meaningfully with tools that expand mental capacities.
Collective intelligence	Ability to pool knowledge & compare notes with others toward a common goal.
Judgment	Ability to evaluate the reliability & credibility of different information sources.
Transmedia Navigation	Ability to follow the flow of stories and information across multiple modalities.
Networking	Ability to search for, synthesize, and disseminate information.
Negotiation	Ability to travel across diverse communities, discerning and respecting multiple perspectives, and grasping and following alternative norms.

## Assessment of Literacies

The availability of an ever expanding wealth of information online, alongside the growth in the adoption of web enabled mobile platforms, impacts on how, when, and where we learn, who we learn with, and how we evaluate the legitimacy of information (Haythornthwaite & Andrews, 2011). Anywhere anytime learning now occurs with potential learners engaging with mentors, peers, and experts with minimal regard to time or place. These learner empowered collaborations complement recent research related to teaching and learning where social learning is viewed as the primary framework for effective pedagogical practice (J. S. Brown & Adler, 2008; Siemens, 2005). While embracing the pedagogical benefits that technology brings to bear to the education context, there is an associated necessity for developing "new and better ways

to measure” learning (U.S. Department of Education Office of Educational Technology, 2010, p.xi).

Government calls for education accountability through standardized testing has in part reinforced the concept of a ‘back to basics’ literacy approach. Standardized testing using more traditional assessment methods drastically limits the evaluation of the social and cultural skills and competencies associated with participatory skills. This point is emphasized by Mary Kalantzis and colleagues (2003) in noting that “accountability and commensurability has focused global attention on producing education outcomes which are simple to interpret, tangible and transparent, and easily comparable” (p. 15). There is a need to examine alternate assessment approaches that can complement calls for accountability and standardization against an imperative for implementing new approaches that can measure the full spectrum of multiliteracies. More recently, Literat (2014) noted that the few studies that have attempted to measure literacy have generally focused on an individual’s understanding of text and or audio. Literat argued that alternate assessment methods are required to evaluate a broader suite of literacies. Literat addressed this methodological problem by demonstrating the potential for more psychometric methods to provide potential indicators of new media literacy skills. Literat’s (2014) new media literacy questionnaire begins to illustrate the capacity for alternate approaches to identify potential lead indicators of literacy development and comprehension. As detailed in Table 1 many of the skills are not readily assessed through standardized testing. Literacies such as “play” or “negotiation” are socially embedded and enabled. As a result, effective assessment requires a more nuanced and diverse approach than is possible through basic knowledge testing.

Alongside the curricular adoption of the skills and competencies associated with multiliteracies, current assessment practices must extend beyond the measurement of outputs to provide greater insight into learning processes (Edwards, 1997). To facilitate this transition, David Boud (2000) maintained that assessment practices cannot remain the “exclusive domain of assessors” (p. 151) as responsibility also resides with the learner. It is only through an individual’s capacity to evaluate, interpret, and make decisions about their learning progress will education foster the skills necessary for capable lifelong learners (Boud, 2000). Boud’s notion of “sustainable assessment” and learner empowerment is in keeping with calls for the development of new assessment practices that address literacies such as creativity, networking, citizenship, and collaboration (Kalantzis et al., 2003). Thus, for education, contemporary assessment practice needs to reflect these community-centric learning models to include measures of learning progression at both the community and individual levels. This is exemplified in Csikszentmihalyi’s (2006) call for creativity to be assessed at the level of community not as an end product derived from a sole individual. However, pressures of accountability, equity, standards, and quality assurance results in a loss of focus on assessment of community in lieu of an individual. It is at this intersection of education accountability and need for collaborative real-time assessment measures that analytics can provide an important role. The following section provides a brief overview of

learning analytics before discussing the alignment of Jenkin's (2006) new media literacies with learning analytics indicators. This example is used to illustrate how analytics can provide insight into individual and community based learning for the 21<sup>st</sup> century.

## What are Learning Analytics?

The field of education has entered the era of “big data”. The McKinsey report (2011) defines “big data” as a “dataset whose size is beyond the ability of typical database software tools to capture, store, manage and analyze” (p. 1). As noted in the report, while the definition is subjective, the ‘big data’ concept relates to the flood of data that is generated and captured as users interact with the myriad of IT systems that support daily activities from iTunes, Twitter, and YouTube through to ecommerce and public services. In an education context, student information systems and learner interactions with various technologies such as learning management systems (LMS) and social media leave a trail of digital breadcrumbs that are accessible for data mining and analysis (Buckingham Shum & Ferguson, 2012; Duval, 2011; Fournier, Kop, & Sitlia, 2011; Macfadyen & Dawson, 2010). The extraction and analysis of the data derived from these technologies has captured the attention of politicians, education leaders, researchers, and day to day education practitioners. This is partly due to the expectation that these relatively new forms of, and processes for, analytics can address some of the more pressing concerns confronting the education sector. These concerns include increasing completion rates, addressing basic curriculum standards, student questionnaire overload, accountability and measuring teaching effectiveness and quality. Although to date the field of learning analytics has largely focused on learner progression and developing lead indicators of student attrition (Campbell, De Blois, & Oblinger, 2007; Fritz, 2011), there is much potential (and some early research) in using student interaction data to establish indicators of more complex concepts such as knowledge construction (Pozzi, Manca, Persico, & Sarti, 2007), sense of community (Dawson, 2006; Gasevic, Adesope, Joksimovic, & Kovanovic, submitted), creativity (Dawson, 2010; Dawson, McWilliam, & Tan, 2011), and self-regulated learning (Biswas, Jeong, Kinnebrew, Sulcer, & Roscoe, 2010; Winne & Hadwin, 2013).

Learning analytics adopts many of the methods and approaches used by “big data” practitioners, but is specifically defined as “the measurement, collection, analysis and reporting of data about learners and their contexts, for the purposes of understanding and optimizing learning and the environments in which it occurs” (Siemens & Long, 2011). Learning analytics uses the data associated with a learner's interactions with content, other learners, and the educational institution to make decisions and evaluations about teaching practices, personalized content, and needed interventions for learner success. The field draws on and integrates research and methodology related to data mining, social network analysis, data visualization, machine learning, learning sciences, psychology, semantics, artificial intelligence, e-learning, and educational



theory and practice. Learning analytics focuses on the interpretation of the educational data from a learner and teacher orientation. This places as much emphasis on understanding the pedagogical context from where the data is derived as developing statistically robust interpretive and predictive models.

The interest in learning analytics is fuelled by increasing calls for accountability, quest for evidence, and the demonstration of what counts as learning and teaching quality alongside decreasing fiscal resources. Similarly, the accessibility to student learning data from various information systems has also contributed to the use of learning analytics as a tool for measuring impact and informing the strategic decision making process within education organizations (Macfadyen & Dawson, 2012). Although the concept of using these forms of analytics for informing education practice has been well received, the majority of educational institutions seldom make optimal use of their available data and analytical resources (Norris, Baer, Leonard, Pugliese, & Lefrere, 2008). Furthermore, as a result of the relative infancy of the field of learning analytics, the level and sophistication of the data analysis performed has to date been limited, with a predominance of studies and reports undertaking simple univariate or bivariate analyses (Dawson, Gašević, Siemens, & Joksimovic, 2014). For instance, low-level analysis such as the reporting of student login times, number of posted messages in a discussion forum, or total time online are common analytics approaches. Bivariate analyses have tended to relate the readily accessible learning management system (LMS) data (e.g., number of messages posted, frequency of logins, time online, etc.) to academic performance as measured by grades.

These early studies have served well to raise the profile of learning analytics and to generate interest in the field as a means to improve student retention and success, including the development of early indicators of academic performance through LMS usage trends. The Purdue University course Signals project<sup>2</sup> is an example of early warning systems. The Signals software incorporates student past academic performance, demographics with LMS activity, and engagement to provide a statistical assessment of an individual learner's probability for success (Arnold, 2010). Watson and Gemin (2008) defined "at-risk" as students with a high probability of withdrawing from the course as a result of academic failure, dropping out, or expulsion for behavioral reasons. In the instance of Signals, success is measured by an individual's overall assessment score. The intent of the software is to provide early warning indicators to learners and instructors regarding an individual's risk of course failure or attrition.

The implementation of practices that focus on improving student retention has a direct and easily measurable return on investment and aligns well with numerous federal government initiatives internationally. For instance, the Australian Bradley Report (Bradley, Noonan, Nugent, & Scales, 2008) emphasized the imperative for increasing graduation rates; Singapore's "Thinking Schools, Learning Nation" (Ministry of Education, 1998) called for evidence based policy making; and the US "Building a Grad

---

<sup>2</sup> Purdue University Course Signals: <http://www.itap.purdue.edu/learning/tools/signals/>

Nation” (Balfanz, Bridgeland, Moore, & Fox, 2010) outlined a strategy for addressing the nation’s increasing level of attrition. These types of reports add further weight to the importance of establishing well-grounded processes and practices for informed decision making practice and quality assurance and accountability. However, stated targets for reducing attrition alone, while admirable, takes a simplistic view of the learning process and does little to measure learning of skills and attributes.

Researchers such as Macfadyen and Dawson (2010) have investigated LMS data to predict student academic performance. While these authors used relatively simple metrics such as student grades as an indicator of success, the study incorporated a more sophisticated modeling process to analyze 15 LMS variables to determine and evaluate a best-fit predictive model. The authors note that social learning (such as in a discussion forum) and formative assessment tasks completed accounted for greater than 30% of the variation in student grade. Macfadyen and Dawson’s study moved beyond the incorporation of simple engagement measures such as number of discussion messages posted towards more complex analytic measures such as social network analysis (SNA). The inclusion of social network methods for determining community participation aligns with the move for new media literacies to be evaluated at the level of community (Jackson, 2006). Combining SNA with other more automated qualitative analytics through machine learning and computational linguistics can further enrich the prospects for establishing a meaningful model for evaluating new literacies. For example, while SNA provides an indication of the strength and diversity of relationships an individual actor establishes in a network there is minimal reference to be able to identify the purpose and value of this relationship. In this context, the inclusion of automated content analysis provides added insight that can determine the extent to which an individual demonstrates good participatory practice. More recently, learning analytics research has started to transition to more sophisticated methods targeting discourse, language, and affective learner attributes<sup>3</sup>.

## Literacies and Learning Analytics

The inclusion of methods such as SNA, epistemic network analysis (Shaffer et al., 2009), and affective learner attributes (Baker, D’Mello, Rodrigo, & Graesser, 2010) merged with computational linguistics moves the focus of learning analytics from the measurement of an end *product* towards an evaluation of the *process* of learning. It is unlikely such a model can be developed through a reliance on extracting student assessment data and LMS activity alone. Grades and LMS activity do not sufficiently represent the diversity of social and cultural based interactions students frequently engage in as learning is not the sole domain of formal institutions. This calls for an examination of how student engagement across multiple educational and social systems can be captured and incorporated, including the more qualitative artifacts such as

<sup>3</sup> <http://machineanalytics.org/schedule/>



student discussion postings, essay writing, blog posts, YouTube, Facebook or Twitter feeds. The inclusion of social network methodologies provides a rich stream of data and an important analytical view to determine the types of relationships and extent of participation in defined communities. In this context, analytics can begin to capture the necessary insights that relate the individual to the community – or in the terms of Jenkins, the individual's active engagement in a participatory culture. The following section outlines possible metrics for evaluating multiliteracies. This is not to suggest that existing forms of student assessment should be replaced, but rather the section outlines additional indicators that can further complement the suite of assessment practices regarding an individual's progression and therefore the broader demonstration of new media literacies.

## Using Analytics to Assess Multiliteracies

As with any kind of evaluative measurement, defining an outcome or process's success indicators will guide the selection of tools for assessment. For the purposes of this paper, Jenkins et al.'s proposed new media literacies and definitions (Table 1) will be used as the basis for the learning analytics framework. Jenkins et al.'s multiliteracies have been clustered in order to refine the types of analytical data that can provide sufficient lead indicators of competency. For example, play, performance, and simulation are closely linked in terms of their affinity with problem solving processes, experimentation, and risk taking. This may be realized through activities such as gaming or role play. However, simulation also corresponds to aspects of appropriation, whereby these skills involve a form of creation or co-creation. Items such as collective intelligence, judgment, and negotiation relate to accessing, sharing, and evaluating information and resources within and across networks. The skill of distributed cognition lies in the intersection between accessing and sharing information and navigation and multi-tasking. Figure 1 presents a visualization of the associated grouping of Jenkins et al.'s (2006) classification of media literacies. The four clusters described above can be measured, monitored, and reported through a diversity of analytics and modified for the specific pedagogical context.

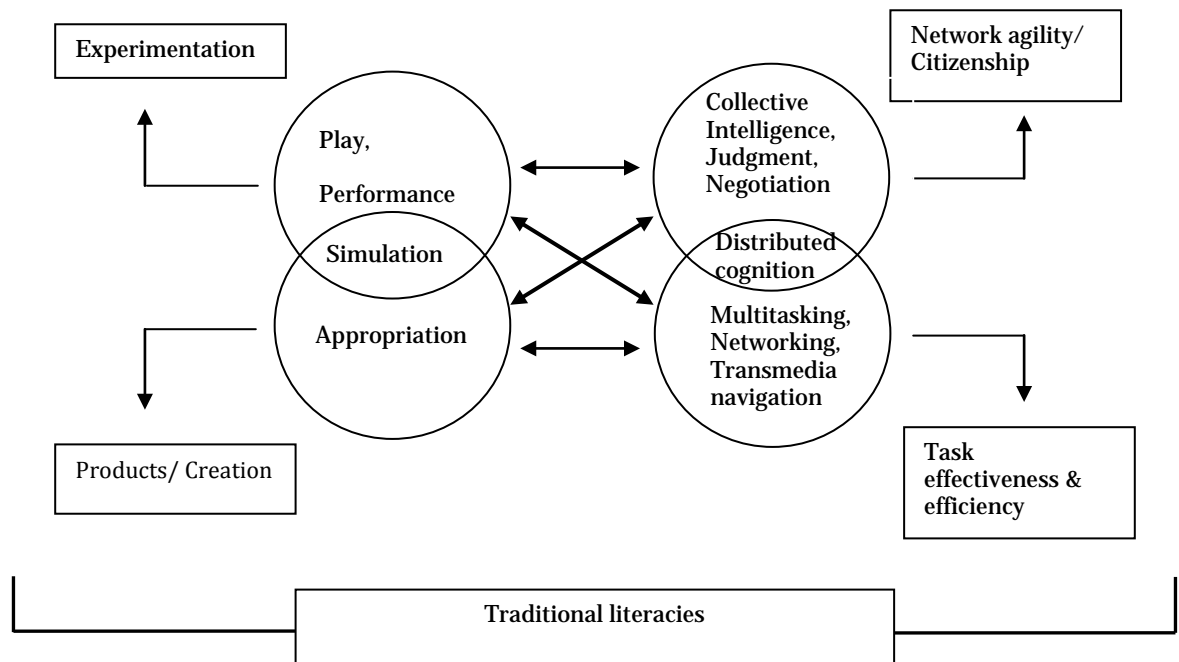

Figure 1. Clustering of media literacies. Adapted from Jenkins et al. (2006).

## Experimentation: Play, Performance, and Simulation

*Experimentation* can be determined through the diversity of user interactions in particular technologies. This may include online games, role playing, or use of assigned simulations. There is a trend for educators to adopt “serious games” and simulations to support the achievement of stated learning objectives (Moreno-Ger, Burgos, Martínez-Ortiz, Sierra, & Fernández-Manjón, 2008). In this context, the use of virtual worlds provides an opportunity for learner experimentation in an immersive environment (De Freitas, Rebolledo-Mendez, Liarokapis, Magoulas, & Poulouvassilis, 2010). User interactions mined from these forms of game based engagement can provide insight into the learner’s competency for play and performance. For example, the degree to which the user engages with the resources, models, pathways, and specific goal oriented outcomes provides an indication of the user’s efficacy for engaging in play activity as well as adopting alternate persona for the purposes of discovery, reflection, and perspective.

## Products/Creation: Appropriation and Simulation

*Products/creation* can be observed directly through the generation of specific artifacts such as multimedia<sup>4</sup>. As such these products, associated methods for creation, and level

<sup>4</sup> See for example <http://ds106.us/> as an artifact-creating online community

of co-creation and engagement can be measured. In Axel Bruns' (2008) terms, the concept of *prod-users* defines a shift away from a model of production to a more collaborative and user-led model of creation. The concept reinforces the notion that any digital product can be remixed and repurposed, and as such is a continual state of flux and evolution. The feedback link from producer to consumer back to producer can be collaborative and completed within an extremely short time frame. Wikipedia illustrates this dynamic and evolving collaborative system. Essentially, the flow and utilization of products as they evolve in both social and cultural importance can act as an indicator of appropriation and simulation.

### Network Agility and Citizenship: Collective Intelligence, Judgment, Negotiation, Distributed Cognition

The skills grouped into *network agility/citizenship* represent an individual's level of competence and capacity for building relationships, participating in networks, and contributing to a community of learners. This cluster relates to a learner's role, position, and contributions to the learning network. This can be readily measured via social network analysis (SNA). The integration of SNA not only provides insight into the strength and diversity of relationships formed but also the types of information or resources shared within the social system (Haythornthwaite, 2002).

In examining the impact of network position and the flow of good ideas Ronald Burt (2004) illustrated the value of SNA to provide insights into network position and information and resource access. In this example, Burt noted that actors bridging two or more previously disparate network clusters demonstrate greater agility and enterprise than peers positioned within an insular network cluster. According to Burt (2004), these individuals "are able to see early, see more broadly, and translate information across groups" (p. 354). Burt sees this 'translating' function as value-adding creativity. This is not just because of the extent to which 'brokers' are able to move knowledge around in value-adding ways, but also their capacity to build, sustain, and expand upon their networks within and outside the existing environment. The skills these "border crossers" (McWilliam & Dawson, 2008) exhibit in order to establish these diverse networks reflect a high level of competence with digital literacies and also demonstrate good participatory practice. Hence understanding can be gained about how social network analysis can assess and provide early indicators of a participatory culture.

Interactions in networks are often more complex than the exchange of information between two or more individuals. Multidimensional networks (Contractor, Monge, & Leonardi, 2011) reflect the more complex interactions that are formed between different technologies and people. As the use of social technologies continues to penetrate the education sector there is an associated increase in opportunity to extract and visualize the relationship data. Aligning SNA or multidimensional network activity with new media literacies, an individual's position in the network and the diversity of relationships formed serves as a measure of their capacity to form relationships, provide and share resources and information (collective intelligence, distributed cognition) as

well as negotiate, adapt, and respect social and cultural community norms (judgment, negotiation). However, while SNA provides a robust approach for ascertaining an individual's network agility there is limited information regarding the quality of the relationships and resources accessed and shared. It is only through an examination of the quality of the exchanges can we begin to evaluate the proficiency of an individual's participatory practices.

The use of content analysis alongside SNA affords rich insights into the quantitative as well as qualitative aspects of a social system. Content analysis is a commonly adopted approach for determining the perceived quality of the knowledge construction process occurring within a learning network (De Laat, 2002; De Laat, Lally, Lipponen, & Simons, 2006). However, the mapping of the captured exchanges to a pre-defined coding scheme has to date been largely a manual and time consuming process. Hence, the level of integration between SNA and content analysis methods has thus far been minimal at best. The adoption of machine learning techniques and tools such as TagHelper (Rose et al., 2007) and Cohere (De Liddo, Buckingham Shum, Quinto, Bachler, & Cannavacciuolo, 2011) demonstrate the potential for automating the coding process and therefore the potential for measuring an individual's network agility and citizenship.

### Task Effectiveness and Efficiency: Multi-Tasking, Networking, Trans-Media Navigation

Measures of *task effectiveness and efficiency* relate specifically to the choice and method for achieving goals and outcomes as well as overall comprehension. For instance, transmedia navigation requires a level of proficiency for interpreting and understanding different representations of information or social and cultural icons and artifacts across and within multiple domains. Networking refers to an individual's competency with various tools and methods for searching, synthesizing, and disseminating information. These characteristics imply a high level of competence and efficiency with accessing tools and resources. As such, the tool selection, search data and techniques, and levels of engagement reflect analytics data to evaluate the characteristics underpinning this cluster. Kennedy and Judd (2011; 2004) examined digital audit trails of a student's activity within various technologies in order to identify specific patterns of behavior. The authors concluded that the audit trails provided significant interpretive power regarding an individual's learning behavior, search process, and tool selection. By further incorporating a level of semantic analysis it is possible to also establish a user's search term technique based on specific request and tasks. These forms of analysis provide a measure of a user's competency with information evaluation and use in different settings and across various media.

Table 2

*Artifacts Generated for Assessment as Exhibited by Different Literacies*

New media literacies	Examples of artifacts produced
Play	Interactions generated in game or simulation settings, evidence of experimentation through novel combinations of game artifacts (Shaffer et al., 2009)
Performance Simulation	Video, creations, digital artifacts, activity in case study Recordings of activity within simulations, ability to review, reflect, and peer critique
Appropriation	Using, combining, and remixing digital artifacts from other learners
Multitasking	Data collected from learners activity in a virtual machine environment (Pardo & Kloos, 2011), recordings made with tracking software
Distributed cognition	Use of range of digital tools for information search, discovery, and sharing
Collective intelligence	Social network interactions, concept development in group work, “on task” contributions in discussions and with artifacts
Judgment	Contrary views presented, tone and sentiment of text/audio/video reflect questioning and critical orientation (De Liddo et al., 2011)
Transmedia navigation	Use of tags, conversation flow across tools/spaces (Rose et al., 2007)
Networking	Trails of interactions, networks and search queries (Judd & Kennedy, 2011)
Negotiation	Debate, discourse tools, give and take interactions in knowledge development (Pozzi et al., 2007)

The media literacies described are still reliant upon an individual student demonstrating a certain level of competency in the more traditional literacies (Jenkins et al., 2006). A student who has limited reading and writing proficiency will continue to struggle with new media literacies. As depicted in Figure 1, the traditional literacies are the foundation for all other literacies. These basics can be evaluated through automated content analysis. Textual passages can be extracted from student activity with blogs, wikis, traditional writing assignments, discussion forum activity, even Twitter posts. However, while this data can be mined and analysed, an understanding of the learning design is essential for establishing meaningful indicators and assessment of an individual’s proficiency within one or more literacy (Lockyer, Heathcote, & Dawson, 2013).

Learning analytics and educational data mining frameworks have been created by researchers to describe the range of activity, in terms of techniques and applications, undertaken by researchers working with learning-related data (Baker & Yacef, 2009; Bienkowski, Feng, & Means, 2012; Siemens, 2013). These suggested frameworks reflect a sequential maturing and refinement of analytics work whereby the more recent work undertaken by Siemens incorporates and builds upon the earlier studies. Siemens’

framework comprises two related components: analytics techniques and applications. Analytic techniques include: modeling; relationship mining; and knowledge domain mapping. Analytic applications involve: applications; prediction; personalization and adaptive learning; and structured mapping. Mapping the proposed four multiliteracies (see Figure 1), experimentation, products/creation, network agility and citizenship, and task effectiveness and efficiency, to an existing framework of learning analytics techniques and applications (Siemens, 2013) can provide the analytics opportunities as described in Table 3.

Table 3

*Mapping Multiliteracies to Learning Analytics Techniques and Applications*

Multiliteracy	Learning analytics techniques & applications
Experimentation	Modeling Knowledge domain mapping
Products & Creation	Personalization Structured mapping Prediction
Network agility & citizenship	Relationship mining Modeling
Task effectiveness and efficiency	Structured mapping Prediction

## Conclusion

With growing interest in data and analytics in the education sector, it is important for researchers, educators, learners, and administrators to have tools and techniques that go beyond surface-level analytics. The complexity of a social process in learning cannot be adequately assessed through basic metrics such as logins, time online, and clicks. Multiliteracies draw attention to the skills and attributes learners require to navigate the increasingly complex technical, social, cultural, and economic worlds. However, traditional models of standardized assessment do little to either promote or effectively measure these multiliteracies (I. Brown et al., 2010; Kalantzis et al., 2003).

This paper builds upon established theoretical models to demonstrate the role learning analytics can play in assisting educators and students in developing real-time feedback and analytics for evaluating literacies. Thus, the significance of the model resides in its capacity to provide deep and nuanced insight into the learning activities of students and to merge the boundary between multiliteracies and learning analytics. In this context, alternate and diverse assessment techniques and instruments are necessary to better align and reflect the technical and information complexity and multimodal learning that form the core of 21<sup>st</sup> century education.

## References

- Anstey, M., & Bull, G. (2006). *Teaching and learning multiliteracies: Changing times, changing literacies*. Australia: Curriculum Press.
- Arnold, K.E. (2010). Signals: Applying academic analytics. *EDUCAUSE Quarterly Magazine*, 33(1). Retrieved from <http://www.educause.edu/EDUCAUSE+Quarterly/EDUCAUSEQuarterlyMagazineVolum/SignalsApplyingAcademicAnalyti/199385>
- Baker, R.S.J.d, D'Mello, S.K., Rodrigo, M.M.T, & Graesser, A.C. (2010). Better to be frustrated than bored: The incidence, persistence, and impact of learners' cognitive–affective states during interactions with three different computer-based learning environments. *International Journal of Human-Computer Studies*, 68(4), 223-241.
- Baker, R.S.J.d, & Yacef, K. (2009). The state of educational data mining in 2009: A review and future visions. *Journal of Educational Data Mining*, 1(1), 3-17.
- Balfanz, R., Bridgeland, J.M., Moore, L.A., & Fox, J.H. (2010). Building a grad nation: Progress and challenge in ending the high school dropout epidemic. Retrieved from <http://www.americaspromise.org/Our-Work/Grad-Nation/Building-a-Grad-Nation.aspx>.
- Bienkowski, M., Feng, M., & Means, B. (2012). Enhancing teaching and learning through educational data mining and learning analytics: An issue brief. *US Department of Education, Office of Educational Technology*, 1-57.
- Biswas, G., Jeong, H., Kinnebrew, J., Sulcer, B., & Roscoe, R. (2010). Measuring self-regulated learning skills through social interactions in a teachable agent environment. *Research and Practice in Technology-Enhanced Learning (RPTEL)*, 5(2), 123-152.
- Boud, D. (2000). Sustainable assessment: Rethinking assessment for the learning society. *Studies in Continuing Education*, 22(2), 151-167.
- Bradley, D., Noonan, P., Nugent, H., & Scales, B. (2008). Review of Australian higher education: Final report. Canberra: Department of Education, Employment and Workplace Relations.
- Brown, I., Lockyer, L., & Caputi, P. (2010). Multiliteracies and assessment practice. In D. R. Cole & D. R. Pullen (Eds.), *Multiliteracies in motion: Current theory and practice* (pp. 191-206). New York: Routledge.
- Brown, J.S., & Adler, A.P. (2008). Minds on fire: Open education, the long tail, and learning 2.0. *EDUCAUSE Review*, 43(1), 16-32.



- Bruns, A. (2008). *Blogs, Wikipedia, Second life, and beyond: From production to produsage*. New York: Peter Lang Publisher.
- Buckingham Shum, S., & Ferguson, R. (2012). Social learning analytics. *Educational Technology & Society, 15*(3), 3-26.
- Burt, R. (2004). Structural holes and good ideas. *The American Journal of Sociology, 110*(2), 349-399.
- Campbell, J., De Blois, P.B., & Oblinger, D. (2007). Academic analytics: A new tool for a new era. *EDUCAUSE Review, 42*(4), 42-57.
- Coiro, J., Knobel, M., Lankshear, C., & Leu, D. J. (Eds.). (2014). *Handbook of research on new literacies*. New York: Routledge.
- Contractor, N.S., Monge, P.R., & Leonardi, P.M. (2011). Multidimensional networks and the dynamics of sociomateriality: Bringing technology inside the network. *International Journal of Communication, 5*, 682-720.
- Cope, B., & Kalantzis, M. (2000a). *Multicultural Education - an equity framework: South Australian Department of Education Curriculum Standards and Accountability Framework*. Adelaide: South Australia Department of Education.
- Cope, B., & Kalantzis, M. (Eds.). (2000b). *Multiliteracies: Learning and the design of social futures*. London: Routledge.
- Csikszentmihalyi, M. (2006). Foreword: Developing creativity. In N. Jackson, M. Oliver, M. Shaw & J. Wisdom (Eds.), *Developing creativity in higher education: An imaginative curriculum* (pp. xviii-xx). London: Routledge.
- Dator, J. (2005). Universities without "quality" and quality without "universities". *On the Horizon, 13*(4), 199-215.
- Dawson, S. (2006). Relationship between student communication interaction and sense of community in higher education. *Internet and Higher Education, 9*(3), 153-162.
- Dawson, S. (2010). 'Seeing' the learning community: An exploration of the development of a resource for monitoring online student networking. *British Journal of Educational Technology, 41*(5), 736-752.
- Dawson, S., Gašević, D., Siemens, G., & Joksimovic, S. (2014). *Current state and future trends: A citation network analysis of the learning analytics field*. Paper presented at the Fourth International Conference on Learning Analytics And Knowledge (LAK '14), Indianapolis, USA.



- Dawson, S., McWilliam, E., & Tan, J. (2011). Measuring creative potential: Using social network analysis to monitor and develop learners' creative capacity. *Australasian Journal of Educational Technology*, 27(6), 924-942.
- De Freitas, S., Rebolledo-Mendez, G., Liarokapis, F., Magoulas, G., & Poulouvassilis, A. (2010). Learning as immersive experiences: Using the four-dimensional framework for designing and evaluating immersive learning experiences in a virtual world. *British Journal of Educational Technology*, 41(1), 69-85.
- De Laat, M. (2002). *Network and content analysis in an online community discourse*. Paper presented at the Computer-Supported Collaborative Learning, Boulder, Colorado.
- De Laat, M., Lally, V., Lipponen, L., & Simons, R. J. (2006). Analysing student engagement with learning and tutoring activities in networked learning communities: A multi-method approach. *International Journal of Web Based Communities*, 2(4), 394-412.
- De Liddo, A., Buckingham Shum, S., Quinto, I., Bachler, M., & Cannavacciuolo, L. (2011). *Discourse-centric learning analytics*. Paper presented at the Proceedings of the 1st International Conference on Learning Analytics and Knowledge, Banff, Alberta, Canada.
- Duval, E. (2011). *Attention please! Learning analytics for visualization and recommendation*. Paper presented at the Proceedings of 1st International Conference on Learning Analytics and Knowledge, Banff, Canada.
- Edwards, R. (1997). *Changing places? Flexibility, lifelong learning and a learning society*. London: Routledge.
- Fournier, H., Kop, R., & Sitlia, H. (2011). *The value of learning analytics to networked learning on a personal learning environment*. Paper presented at the 1st International Conference on Learning Analytics and Knowledge Banff, Alberta, Canada.
- Fritz, J. (2011). Classroom walls that talk: Using online course activity data of successful students to raise self-awareness of underperforming peers. *The Internet and Higher Education*, 14(2), 89-97.
- Garrison, D.R. (1997). Self-directed learning: Toward a comprehensive model. *Adult Education Quarterly*, 48(1), 18-33.
- Gasevic, D., Adesope, O., Joksimovic, S., & Kovanovic, V. (submitted). Externally-facilitated regulation scaffolding and role assignment to develop cognitive presence in asynchronous online discussions. *The Internet and Higher Education*.

- Gee, J.P. (2007). *Good video games + good learning: Collected essays on video games, learning and literacy*. New York: Peter Lang.
- Gee, J.P. (2009). Reflections on reading Cope and Kalantzis' "Multiliteracies: New literacies, new learning". *Pedagogies: An International Journal*, 4, 196-204.
- Greenhow, C., & Robelia, B. (2009). Old communication, new literacies: Social network sites as social learning spaces. *Journal of Computer-Mediated Communication*, 14(4), 1130-1161.
- Haythornthwaite, C. (2002). Building social networks via computer networks: Creating and sustaining distributed learning communities. In K. A. Renninger & W. Shumar (Eds.), *Building virtual communities: Learning and change in cyberspace* (pp. 159-190). New York: Cambridge University Press.
- Haythornthwaite, C., & Andrews, R. (2011). *E-Learning theory and practice*. London, UK: Sage Publications.
- Huijser, H. (2006). Refocusing multiliteracies for the net generation. *International Journal of Pedagogies & Learning*, 2(1), 22-34.
- Jackson, N. (2006). Imagining a different world. In N. Jackson, M. Oliver, M. Shaw & J. Wisdom (Eds.), *Developing creativity in higher education: An imaginative curriculum*. London: Routledge.
- Jenkins, H., Clinton, K., Purushotma, R., Robison, A. J., & Weigel, M. (2006). *Confronting the challenges of participatory culture: Media education for the 21st century*. Chicago, IL: MacArthur Foundation.
- Judd, T., & Kennedy, G. (2011). Measurement and evidence of computer-based task switching and multitasking by 'Net Generation' students. *Computers & Education*, 56(3), 625-631. doi: 10.1016/j.compedu.2010.10.004
- Kalantzis, M., Cope, B., & Harvey, A. (2003). Assessing multiliteracies and the new basics. *Assessment in Education: Principles, Policy & Practice*, 10(1), 15-26.
- Kalman, J. (2008). Beyond definition: Central concepts for understanding literacy. *International Review of Education*, 54(5/6), 532-538.
- Kennedy, G., & Judd, T. (2004). Making sense of audit trail data. *Australian Journal of Educational Technology*, 20(1), 18-32.
- Kress, G. (2003). *Literacy in the new media age*. London: Routledge.
- Lankshear, C., & Knobel, M. (2003). *New literacies: Changing knowledge in the classroom*. Buckingham, UK: Open University Press.

- Lankshear, C., & Knobel, M. (2007). A new literacies sampler. In M. Knobel & C. Lankshear (Eds.), *Sampling "the new" in new literacies* (Vol. New literacies and digital epistemologies, pp. 1-24). New York: Peter Lang.
- Lave, J., & Wenger, E. (1991). *Situated learning: Legitimate peripheral participation*. Cambridge: Cambridge University Press.
- Leadbeater, C., & Wong, A. (2009). Learning from the extremes: Strategies for radical social innovation ([http://www.cisco.com/web/about/citizenship/socio-economic/docs/LearningfromExtremes\\_WhitePaper.pdf](http://www.cisco.com/web/about/citizenship/socio-economic/docs/LearningfromExtremes_WhitePaper.pdf)). Cisco.
- Literat, I. (2014). Measuring new media literacies: Towards the development of a comprehensive assessment tool. *Journal of Media Literacy Education*, 6(1), 15-27.
- Lockyer, L., Heathcote, E., & Dawson, S. (2013). Informing pedagogical action: Aligning learning analytics with learning design. *American Behavioral Scientist*, 57(10), 1439-1459.
- Macfadyen, L., & Dawson, S. (2010). Mining LMS data to develop an "early warning system" for educators: A proof of concept. *Computers & Education*, 54(2), 588-599.
- Macfadyen, L., & Dawson, S. (2012). Numbers are not enough. Why e-Learning analytics failed to inform an institutional strategic plan. *Educational Technology & Society*, 15(3), 149-163.
- McKinsey Global Institute. (2011). *Big data: The next frontier for innovation, competition, and productivity*. Retrieved from [http://www.mckinsey.com/Insights/MGI/Research/Technology\\_and\\_Innovation/Big\\_data\\_The\\_next\\_frontier\\_for\\_innovation](http://www.mckinsey.com/Insights/MGI/Research/Technology_and_Innovation/Big_data_The_next_frontier_for_innovation).
- McWilliam, E., & Dawson, S. (2008). Pedagogical practice after the Information Age. In S. Inayatullah, I. Milojevic & S. Bussey (Eds.), *Alternative educational futures: Pedagogies for emergent worlds* (Vol. 130-144). The Netherlands: Sense Publishers.
- Ministry of Education. (1998). *Learning to think, thinking to learn: Towards thinking schools, learning nation*. Singapore: Ministry of Education.
- Moreno-Ger, Pablo, Burgos, Daniel, Martínez-Ortiz, Iván, Sierra, José Luis, & Fernández-Manjón, Baltasar. (2008). Educational game design for online education. *Computers in Human Behavior*, 24(6), 2530-2540.
- Muspratt, A., Luke, A., & Freebody, P. (Eds.). (1998). *Constructing critical literacies: Teaching and learning textual practice*. Cresskill, NJ: Hampton.

- New London Group. (1996). A pedagogy of multiliteracies: Designing social futures. *Harvard Educational Review*, 66, 60-92.
- Norris, D., Baer, L., Leonard, J., Pugliese, L., & Lefrere, P. (2008). Action analytics: Measuring and improving performance that matters in higher education. *EDUCAUSE Review*, 43(1), 42-67.
- Pardo, A., & Kloos, C.D. (2011). *Stepping out of the box: Towards analytics outside the learning management system*. Paper presented at the Proceedings of the 1st International Conference on Learning Analytics and Knowledge, Banff, Alberta, Canada.
- Pozzi, F., Manca, S., Persico, D., & Sarti, L. (2007). A general framework for tracking and analysing learning processes in computer-supported collaborative learning environments. *Innovations in Education and Teaching International*, 44(2), 169-179.
- Rose, C., Wang, Y., Cui, Y., Arguella, J., Stegmann, K., Weinberger, A., & Fischer, F. (2007). Analyzing collaborative learning processes automatically: Exploiting the advances of computational linguistics in computer-supported collaborative learning. *International Journal of Computer-Supported Collaborative Learning*, 3(3), 237-272.
- Shaffer, D. W., Hatfield, D., Svarovsky, G. N., Nash, P., Nutly, A., Bagley, E., . . . Mislevy, R. (2009). Epistemic network analysis: A prototype of 21st-century assessment of learning. *International Journal of Learning and Media*, 1(2), 33-53.
- Siemens, G. (2005). A learning theory for the digital age. *Instructional Technology and Distance Education*, 2(1), 3-10.
- Siemens, G. (2013). Learning analytics the emergence of a discipline. *American Behavioral Scientist*, 57(10), 1380-1400.
- Siemens, G., & Long, P. (2011). Penetrating the fog: Analytics in learning and education. *EDUCAUSE Review*, 46(5), 30-40.
- U.S. Department of Education Office of Educational Technology. (2010). *Transforming American education: Learning powered by technology*. Washington, D.C.
- UNESCO Education Sector. (2004). *The plurality of literacy and its implications for policies and programs: Position paper*. Paris: UNESCO. Retrieved from <http://unesdoc.unesco.org/images/0013/001362/136246e.pdf>.
- Unsworth, L. (2001). *Teaching multiliteracies across the curriculum: Changing contexts of text and image in classroom practice*. Buckingham: Open University Press.

- Warschauer, M. (2007). The paradoxical future of digital learning. *Learning Inquiry*, 1(1), 41-49. doi: 10.1007/s11519-007-0001-5
- Watson, J., & Gemin, B. (2008). *Using online learning for at-risk students and credit recovery*. Washington, DC: International Council for K-12 Online Learning.
- Winne, P. H., & Hadwin, A. F. (2013). nStudy: Tracing and supporting self-regulated learning in the Internet. In R. Azevedo & V. Alevén (Eds.), *International handbook of metacognition and learning technologies* (pp. 293-308). Amsterdam: Springer.

Athabasca University 



## Educational Triage in Open Distance Learning: Walking a Moral Tightrope



Paul Prinsloo<sup>1</sup> and Sharon Slade<sup>2</sup>

<sup>1</sup>University of South Africa, <sup>2</sup>Open University, UK

### Abstract

Higher education, and more specifically, distance education, is in the midst of a rapidly changing environment. Higher education institutions increasingly rely on the harvesting and analyses of student data to inform key strategic decisions across a wide range of issues, including marketing, enrolment, curriculum development, the appointment of staff, and student assessment. In the light of persistent concerns regarding student success and retention in distance education contexts, the harvesting and analysis of student data in particular in the emerging field of learning analytics holds much promise. As such the notion of educational triage needs to be interrogated. Educational triage is defined as balancing between the futility or impact of the intervention juxtaposed with the number of students requiring care, the scope of care required, and the resources available for care/interventions.

The central question posed by this article is “how do we make moral decisions when resources are (increasingly) limited?” An attempt is made to address this by discussing the use of data to support decisions regarding student support and examining the concept of educational triage. Despite the increase in examples of institutions implementing a triage based approach to student support, there is a serious lack of supporting conceptual and theoretical development, and, more importantly, to consideration of the moral cost of triage in educational settings.

This article provides a conceptual framework to realise the potential of educational triage to responsibly and ethically respond to legitimate concerns about the “revolving door” in distance and online learning and the sustainability of higher education, without compromising ‘openness.’ The conceptual framework does not attempt to provide a detailed map, but rather a compass consisting of principles to consider in using learning analytics to classify students according to their perceived risk of failing and the potential of additional support to alleviate this risk.

**Keywords:** Distance education; educational triage; learning analytics; open distance learning

## Introduction

Are students walking around with invisible triage tags attached, that only lecturers can see? Is this fair? Or is it just pragmatic? Like battlefield medical attention, lecturers' attention is finite. And as class sizes and workloads increase, it is becoming scarcer. (Manning, 2012)

While *The New York Times* announced that 2012 was “the year of the MOOC” (Pappano, 2012), by the start of 2014 there were signs that some of the initial hype had died down (Wetterstrom, 2014). Despite a (possibly) more sober assessment regarding the promise of massive open online education, *The Economist* (2014, June 28<sup>th</sup>-July 4<sup>th</sup>) dedicated their weekly issue to the “creative destruction” facing higher education and the ‘reinvention’ of the university. It is therefore difficult to estimate the scope and real impact of the changes facing international and national higher education. Over the last three years, terms such as “disaggregation” (Wiley & Hilton III, 2009), relating to the competitive nature of higher education, “unbundling and unmooring” (Watters, 2012), referring to the disruption caused by the introduction of new technologies in combination with ever changing external factors, “academic revolution” (Altbach, Reisberg, & Rumbley, 2009), and “crisis” (Carr, 2012), referring to the potential damage caused by the introduction of MOOCs, are increasingly common in discourses on current and future states of higher education. The higher education landscape may be irrevocably changing (Staley & Trinkle, 2011; *The Economist*, 2014), with some authors even mooting the notion that these ongoing changes herald the “end of higher education’s golden age” (Shirky, 2014). Others, however, question the eschatological terminology used to describe the impact of technological changes in society (Morozov, 2013a, 2013b) and in the current higher education landscape (Watters, 2012) and petition a consideration of the ideological and political agendas informing the current “techno-romanticism” in education (Selwyn, 2014).

Against this backdrop, higher education institutions increasingly need to make strategic decisions to assess and exploit various opportunities, alleviate risk, and ensure the longterm financial viability of institutions of higher learning. Risk within higher education not only mirrors broader societal dimensions of risk, but also includes the danger of obsolescence, the impact of technology on content, assessment, and the role of faculty, the increasing diversification of forms of higher education and student populations, and concerns about student success and retention (Altbach, Reisberg, & Rumbley, 2009; Siemens & Long, 2011; Newman, Couturier, Scurry, 2010; and Slaughter & Rhoads, 2010). In particular, concerns about student success and retention



continue to increase in intensity amidst changes in funding frameworks, higher education ranking tables, consumer activism amongst students, and employer needs.

As early as 1995, Hartley pointed to the impact of external scrutiny, inspection, and the increasing emphasis on efficiency, calculability, predictability, control, and fake fraternisation in higher education. Expanding on the principles provided by Bentham's work on education in 1816, Hartley (1995) explores the notion of the "McDonaldisation" of higher education with its emphasis on the optimisation of increasingly scarce resources with its maxim of "doing more with less" (p. 412). Shifts in funding frameworks facing higher education were visible as early as 1995 – resulting in funding following rather than preceding performance (Hartley, 1995). In the same year, with respect to the debates surrounding higher education, Lagowski (1995) stated that commentators "claim that we [higher education] cost too much, spend carelessly, teach poorly, plan myopically, and when questioned, act defensively" (p. 861) and, as a result, that "higher education will never again be as it was before" (p. 861). The proposed solution then (e.g., Lagowski, 1995) and, increasingly, now is to adopt a triage approach.

Within this context, distance education, and in particular open distance and elearning (ODEL), relies ever more on data to inform its key strategic decisions across a wide range of issues, including marketing, enrolment, curriculum development, the appointment of staff, and student assessment. In an ODeL context, students are typically not required to satisfy pre-entry requirements for admission, nor are they readily available for consultation or direct support in the same sense as on a campus-based institution. Crucially then, data is increasingly harvested and analysed to inform initiatives which might increase student retention and success (Siemens & Long, 2011; Oblinger, 2012). While commercial entities have long since optimised the harvesting and analysis of data to inform their marketing and customer service strategies, and to increase their profitability, learning analytics is a recent phenomenon in the field of higher education, and, more specifically, in ODeL contexts (New Media Consortium, 2014). Learning analytics as a phenomenon "spans the full scope and range of activity in higher education, affecting administration, research, teaching and learning, and support resources" (Siemens & Long, 2011, p. 36). In the above context, it is easy to understand why learning analytics is described as the "new black" (Booth, 2012), or student data as the "new oil" (Watters, 2013). It falls outside the scope of this article to explore the implications of the different terminologies and practices used in the field of student data such as academic and learning analytics (for a clarification of the two terms see Ferguson, 2012; Siemens, 2011; Siemens & Long, 2011). In the context of this article, we focus specifically on the potential of learning analytics to inform educational triage.

The harvesting and analysis of student data in academic and learning analytics therefore offers opportunities for higher education institutions to respond, timeously and appropriately, to identifying students who are at risk of failing or dropping out (Campbell, DeBlois, & Oblinger, 2007; Siemens & Long, 2011). The opportunities offered by learning analytics have, however, also brought to the fore concerns regarding a number of issues such as governmentality, data privacy, consent, and other ethical



issues and challenges (Slade & Prinsloo, 2013; Booth, 2012; Clow, 2012, 2013; Long & Siemens, 2011; May, 2011; Oblinger, 2012; Siemens, 2011; and Wagner & Ice, 2012). While it is indisputable that learning analytics offers huge potential for use in the management of teaching and learning in ODeL contexts, it is crucial that we do not negate and/or ignore the potential perils and associated ethical dilemmas (Slade & Prinsloo, 2013). Learning analytics therefore finds itself within the centre of the “tension between the framing of education as an economic activity and conceptions of education and learning that are concerned with the development of meaning and the transformation of understanding” (Clow, 2013a, p. 683). Despite various claims regarding the success of learning analytics to improve student success and retention (e.g., Arnold, 2010; Clow, 2013a, 2013b), Watters (2013) also warns that “the claims about big data and education are incredibly bold, and as of yet, mostly unproven” (par. 17). (For a discussion regarding various claims in the application of learning analytics, see Clow 2013a, 2013b, and 2013c.)

The central question posed by this paper is “how do we make moral decisions when resources are (increasingly) limited?” An attempt is made to address this by discussing the use of data to support decisions regarding student support and examining the concept of educational triage. Despite the increase in examples of institutions implementing a triage based approach to student support, there is a serious lack of supporting conceptual and theoretical development, and, more importantly, to consideration of the moral cost of triage in educational settings. During the literature review the researchers could not find any published articles exploring the theoretical and conceptual bases for educational triage, though some of the literature describe the practical implication of educational triage on primary and secondary school levels (Booher-Jennings, 2005; Cobbold, 2010; Sparks, 2012; Wilson, 2012; Gillborn & Youdell, 2000; and Marks, 2012).

Due to its distinct origins in medical practice, we should consider also whether the notion of triage provides a useful heuristic in educational settings. Biesta (2007, 2010), for example, raises legitimate concerns regarding the transferability of concepts between the medical and educational domains of practice. The fact that something ‘works’ in one context does not necessarily mean that it is appropriate in another context, regardless of whether it appears to work or not.

In this paper we

- briefly introduce learning analytics as a tool in the practice of educational triage;
- provide a short overview of the notion and practice of medical triage, and introduce the idea of educational triage;

- assess the potential of educational triage to responsibly and ethically respond to legitimate concerns about the “revolving door” in distance and online learning and the sustainability of higher education, without compromising ‘openness.’

## Towards a Definition of Learning Analytics

Due to the variety of interpretations and uses of data in higher education, as well as different purposes, skills required, contexts, and tools used in the harvesting and analysis of data, it is crucial to clarify the terms and definitions surrounding learning analytics (Van Barneveld, Arnold, & Campbell, 2012). Siemens and Long (2011) state that the “ubiquity of the term analytics partly contributes to the breadth of meanings attached to it” (p. 34) and clarify the notion of learning analytics by firstly providing a clear definition and secondly juxtaposing learning analytics with academic analytics.

During the first International Conference on Learning Analytics and Knowledge (2011), learning analytics was defined as “the measurement, collection, analysis and reporting of data about learners and their contexts, for purposes of understanding and optimising learning and the environments in which it occurs” (Siemens & Long, 2011, p. 34). Academic analytics, in contrast, is “the application of business intelligence in education and emphasises analytics at institutional, regional, and international levels” (Siemens & Long, 2011, p. 34). Siemens and Long (2011) state that learning analytics is “more specific than academic analytics” in that it focuses “exclusively on the learning process” (p. 34). (For a detailed explanation of the differences between learning and academic analytics, please see Siemens and Long, 2011; and Diaz and Brown, 2012.)

Learning analytics is an “emerging discipline” (Siemens, 2013) and its given role is “to support sensemaking and not to supplant it” so that “learning analytics does not make decisions, it enables them” (Siemens in Diaz & Brown, 2012, p. 3). Byron (in Diaz & Brown, 2012) lists eight practical examples of using learning analytics to support course design and student success at Sinclair Community College in the US. Here, a number of tools are used to

- improve at-risk student retention and success;
- increase the graduation rate of at-risk students;
- implement a systematic, comprehensive counselling and intervention process;
- implement an integrated early-alert process;
- develop and maintain a comprehensive resource of community and college referral sources;
- develop a web-based counselling record(case) management system;

- remove the silos between offices that support students;
- create self-help tools.

Several recent articles summarise the growing awareness of the potential of learning analytics to shape the management of teaching and learning in higher education. For example, Wagner and Ice (2012) explore its potential in an article entitled “Data Changes Everything”. The authors state that the “digital breadcrumbs” and data trails left by students provide higher education with the data necessary to analyse and create “meaningful learning experiences that can engage, inspire, and prepare current and future students for success” (p. 34). Further, Booth (2012) lauds the potential of learning analytics to “harness the power of advances in data mining, interpretation, and modelling to improve understandings of teaching and learning, and to tailor education to individual students more effectively” (p. 52, quoting the New Media Consortium’s 2011 report). *The NMC 2014 Horizon Report* (New Media Consortium, 2014) describes the “rise of data-driven learning and assessment” as a “mid-range trend” (p. 12), impacting on higher education within the next three to five years.

Because much of the data can be gathered in real time, there is a real possibility of continuous improvement via multiple feedback loops that operate at different time scales – immediate to the student for the next problem, daily to the teacher for the next day’s teaching, monthly to the principal for judging progress, and annually to the district and state administrators for overall school improvement. (Bienkowski, Feng, & Means, 2012, pp. vii-viii)

Diaz and Brown (2012), in the broader context of learning analytics, discuss two types of data that students generate during a course namely the “digital footprints, or digital breadcrumbs” left by students as well as “learner-generated data [that] are supplemented or augmented by data about the learner, such as previous coursework, demographics, and other data that might exist in the student information system” (p. 2). These data trails allow higher education institutions to “detect patterns and make predictions” (p. 2). Patterns of sensemaking are informed by comparing individual learners’ activities to the rest of the class, comparing their activities to the levels of activities of students who have taken the course before, or comparing an individual learner’s activity in a particular course with their activities in previous courses, whether at the same institution or at a different institution (Diaz & Brown, 2012). Predictive modelling may then apply various statistical techniques to analyse those data sets in order to make predictions about future behaviours or likely student success.

Learning analytics therefore show promise in informing the design of more effective, appropriate and, importantly, more cost-effective student support. As such, the notion and practice of educational triage needs to be critically interrogated.

## A Short Overview of the History of the Notion of Triage

The concept of triage is more typically associated with medical treatment where it refers to a classification or sorting of injured patients and the subsequent allocation of treatment according to the severity of their wounds. The close association of the concept of triage with military medicine developed in the First World War and continues to this day (Winslow, 1982). The original purpose of triage was to conserve human resources in times of crises and to bear the interests of the sick and wounded in mind.

Triage is described by the World Medical Association (WMA) as prioritising treatment and management “based on rapid diagnosis and prognosis for each patient” (1994, par. 7). The diagnosis and treatment is carried out systematically “taking into account the medical needs, medical intervention capabilities and available resources” (WMA, 1994, par. 7). The basis of triage is therefore the balancing of the scope of treatment in the context of limited resources and health status of patients. The WMA (1994) also acknowledges that triage raises a number of ethical problems.

Triage categorisation (WMA, 1994) involves the following criteria:

1. those who can be saved but requiring immediate treatment (priority 1, immediate);
2. those not in immediate danger but needing urgent medical care (priority 2, delayed);
3. those requiring only minor treatment (priority 3, minimal);
4. those who might need reassurance or sedation (no specific triage tag);
5. those whose condition exceeds the available therapeutic resources, and cannot be saved in the specific circumstances of time and place, or complex cases that require a choice between them and other patients (no priority, expectant).

This final category includes those who are dead or beyond emergency care and, as such, can cause significant unease, but is a vital part of disaster triage systems. As the WMA points out, it is ethical for a physician not to persist, at all costs, in treating individuals “beyond emergency care”, thereby wasting scarce resources needed elsewhere” (1994, par. 10) and “He/she should attempt to set an order of priorities for treatment that will save the greatest number of lives (1994, par. 11).

So, a common thread in medical triage relates to balancing or prioritising between the futility of intervention juxtaposed with the number of patients requiring care, the scope of care required, and the resources available for care/interventions. Beauchamp and Childress (2001) therefore suggest four basic moral principles providing a common framework used in the analysis of medical ethics, namely

1. Respect patient autonomy: the patient has the right to refuse or choose their treatment.
2. The notion of beneficence requiring a practitioner to always act in the best interest of the patient.
3. The need for non-maleficence – "first, do no harm".
4. The scope of justice that includes the distribution of scarce health resources, and deciding who gets what type of treatment and the priority/sequence of treatment. The principle of justice ensures that privilege or other forms of capital should not determine treatment.

Inherent in the discussion and evaluation regarding the futility of medical care for some patients are issues around the nature of relevant information (would a second person come to the same conclusion?), the patient's own evaluation of their condition, other stakeholders' (such as family, peers) evaluations, and balancing the 'cost' of continued or more advanced treatment against the prospects of survival (with futility often defined as a less than 1% chance of survival).

In an interesting development on the work by Beauchamp and Childress (2001), Joynt and Gomersall (2005) suggest two additional pathways to be considered before the above four moral principles apply. These pathways include where the patient him or herself "makes an autonomous, informed decision to decline ICU admission" (p. 34) or where the patient, once selected for care, decides to forego care based on an informed decision that "no meaningful medical benefit can be achieved" (p. 35). Joynt and Gomersall (2005) also point to the fact that prioritisation within the process of triage depends on different fundamental methods such as 'first come, first serve' (a naturally random process), to admitting patients to ICU on the basis of those who would receive the most benefit from being admitted. "Put simply, the society should get more survivors for the same outlay of ICU resources" (pp. 37-38). In this utilitarian approach to triage, "other factors unrelated to benefit such as ethnic origin, race, religion, sex, social status and ability to pay, and age should not be considered as acceptable criteria on which to base a triage decision" (p. 38).

Joynt and Gomersall (2005) point to the fact that there "are enormous difficulties when justifying decisions in relation to prioritisation" (p. 38). As a way to overcome these difficulties, they suggest that a focus on "an acceptable process" instead of focusing only on the moral principles will alleviate some of the practical issues around the justification of triage. The proposed process contains four key procedural elements, namely

- the need for transparency where all relevant parties, "including the public have complete access to the decisions and the reasons for the decisions";
- the "use of any rationales that all parties can accept are relevant to the fair use of the health resources in question";

- to ensure that “a formal and accessible mechanism should exist for appeals or challenges”;
- an “oversight mechanism, preferably external” that exists to “monitor the first three conditions” (p. 38).

In considering the triage decision-making process it is crucial to understand that, due to the “complexity of disease and heterogeneous nature of general ICU patients and our lack of quantitative knowledge of ICU outcomes”, it is almost impossible to “define enough specific conditions under which individual triage decisions should be made” (p. 38). Joynt and Gomersall (2005) therefore propose the following essential components of triage decisions:

- an assessment of the diagnosis, prognosis and outcome;
- a statement of the degree of benefit expected for the patient admitted, and supporting evidence of this assessment;
- a statement clearly making the decision and identifying it as a triage decision;
- the identity and qualifications of the physician/s responsible for the decision;
- a statement confirming that clear communication of relevant factors with the patient/family/other caregivers has taken place – including, among others, inquiry into the patient’s current and expected quality of life;
- a statement that the decision and reason for that decision has been communicated to the family and relevant caregivers should conclude the documentation (pp. 39-40).

From this brief discussion it is clear that “making moral decisions when resources are limited” (Joynt & Gomersall, 2005, p. 34) is complex and difficult. In attempting to take consideration of this approach within an educational context, we need to consider not only the four principles suggested by Beauchamp and Childress (2001), but also the procedural elements proposed by Joynt and Gomersall (2005). The next section brings to the fore the growing importance of student retention within higher education and the use of data to identify students at risk of (passive) withdrawal or failure. The concept of educational triage is then introduced to describe ways in which educational institutions are beginning to make conscious decisions regarding which students are selected to receive targeted support based on their own data trails (and by association, which students are not).

## Triage in (Higher) Education

The picture of (often) dismal student retention and course success rates in higher education in general, and distance education in particular, can paint pictures of students as the “walking wounded” (Graber, 1996), with higher education seen as a “revolving door” (Barefoot, 2004; and Yorke, 2004). Indeed, higher education has been described as a “battlefield” (Kogan, 1987, p. 68), referring to the tussle between administrative and academic staff (Waugh, 1998) or the increasing competition in internationalised higher education (Rust & Kim, 2012). The concept of the ‘wounded’ student is embedded in many current practices in higher education (Manning, 2012).

In the context of this article, the ‘wounded’ in higher education may therefore refer to those students who are at risk of not surviving the ordeal, by either dropping out of their studies or (continuous) failing. Not only do students’ failure and dropout constitute a risk for students, but they pose an increasing risk for the sustainability of higher education. Educational triage is therefore defined as balancing between the futility or impact of the intervention juxtaposed with the number of students requiring care, the scope of care required, and the resources available for care/interventions.

There is, however, an inherent moral dilemma in allocating the risk and the scope of risk *just* to students – as if higher education institutions are always effective and fair, and, secondly, as if macro-societal influences such as an economic downturn or retrenchment do not impact on students’ ability to survive higher education (Prinsloo, 2009; and Subotzky & Prinsloo, 2011). Student success and retention (as well as its opposite of failure and dropout) are the result of a complex, multidimensional ecology with many different and often mutually constitutive variables dynamically interacting (Prinsloo, 2009). This seems to point to the need to reconsider the definition and scope of educational triage as a means of directing support toward students most likely to ‘survive’ as one solely based on student deficiency, especially when considering factors impacting on student success and retention of students from disadvantaged or minority backgrounds (Grimes, 1997; McInerney & King, 2013; and Rovai, 2002). The role of learning analytics as a means of applying triage in this sense is the ease with which higher education institutions can now track and predict potential failure by applying models with data submitted and generated by students.

The notion of triage is reasonably well established in the contexts of primary and secondary school education (Booher-Jennings, 2005; Cobbold, 2010; Sparks, 2012; Wilson, 2012; Gillborn & Youdell, 2000; and Marks, 2012). There is, however, a lack of direct referencing to the notion of triage in higher education research, though issues of optimisation, analytics, and addressing the needs of under-prepared students are well-documented.

In secondary education within the United Kingdom, educational triage is common practice as schools are subject to public comparison via published league tables which focus on the percentage of students receiving grades in the higher bands (5 A\*-C grades



including English and Mathematics). In order to maintain or improve league positions (which are felt to directly link to future income), additional resource may be directed toward those students in danger of not achieving the minimum C grade, often at the expense of those who will confidently achieve an acceptable grade (but who might have done even better with additional help) and those who are too far from the grade to be worth saving. In fact, a study in 2005 of all pupil level data for secondary state schools in England found that low ability students do worse in schools where there are more students on the C/D border as a result of the redirection of resource (Burgess, Propper, Slater, & Wilson, 2005). Indeed, Crehan (2012) argues that the continued focus on percentage based measures and league tables drives the practice of triage by encouraging a concentration of effort at the point where it will have the most impact on the target measures.

Cobbold (2010) agrees that the practice of triage in schools may be considered strategically sensible, but expresses concerns about the broader impact on those students who may be impacted by what is perhaps predominately a public relations exercise. He cites the allocation of the most experienced teachers to identified students, the abandonment of those students too weak in one of the core subjects, and the sheer cynicism of the approach which seemed to be for the benefit of headline figures rather than to enable pupils to achieve their individual potential. Cobbold suggests that such practice exists in other countries too, citing the Australian Primary Principals Association's concerns that many schools allocate more resources to those students most likely to improve school results (the NAPLAN tests) and that students with greater needs received less until after completion of tests.

## Triage and Open Distance and E-Learning: Mapping the Risks and Potential

There is very little if any published research on the philosophical and theoretical underpinnings of educational triage, and its practice in the context of higher education. Though there is ample evidence of different forms of educational triage in higher education, for example, the Signals project at Purdue University (Arnold, 2010; Caulfield, 2013; Essa, 2013; Clow, 2013a, 2013b; and Straumsheim, 2013), and two projects at the University system of Maryland namely at the University of Maryland Eastern Shore (UMES) and Bowie State University (BSU) (Forsythe, Chacon, Spicer, & Valbuena, 2012), there is very little information available on the conceptual and moral considerations and implications of these projects.

In this article we attempted to map not only the historical development (Winslow, 1982) and moral principles (Beauchamp & Childress, 1994) and guiding processes (Joynt & Gomersall, 2005) inherent in triage within the context of medicine, but we have also raised a number of concerns regarding the function of algocracies (Danaher, 2014a; Marwick, 2014; and Morozov, 2013a, 2013b) in the discourses of accountability and



governmentality in higher education (Beer, Jones, & Clark, 2012; Clow, 2013a; and Morozov, 2013b).

In this section we would like to provide a draft heuristic for positioning educational triage as moral practice. The growing prominence of a learning analytics approach to shaping student support within our higher education institutions now requires an examination of the principles which underlie how that support is allocated. Continuation along a path whereby support is determined by data and algorithms alone may quickly result in an approach to support at direct odds with the underlying principles of an institution.

Firstly it is important to take cognizance of the historical (Hartley, 1995) and current emphasis on the optimisation of resources in higher education (Long & Siemens, 2011) as a reality. This does not mean, however, that we support the “McDonaldisation” (Hartley, 1995) or continuing hegemony of neoliberal ideologies in higher education (Slaughter & Rhoades, 2010). Our approach to triage as moral educational practice is, on the one hand, acknowledging the reality of funding constraints and, on the other hand, contesting a technocratic approach to the allocation of resources to improve the effectiveness of teaching and learning (Morozov, 2013a, 2013b; and Slaughter & Rhoades, 2010). We believe that learning analytics as moral practice (Slade & Prinsloo, 2013) not only provides opportunities for more effective teaching and learning and allocation of resources (Long & Siemens, 2011), but also addresses the question “how do we make moral decisions when resources are (increasingly) limited?” (e.g., Joynt & Gomersall, 2005).

Slade and Prinsloo (2013) proposed a number of principles underlying learning analytics as moral practice which include recognising that learning analytics (and implicitly educational triage) can be immoral. Their proposed principles include recognising the agency of students and the identity and performance of students as dynamic constructs. Student success is furthermore a “complex and multidimensional phenomenon” (p. 1520) and higher education cannot afford not to use data to support student learning. (For a full discussion on a framework for learning analytics as moral practice, see Slade and Prinsloo, 2013.)

Based on the potential of learning analytics as moral practice, it follows that educational triage, in the context of limited resources, will involve making difficult decisions. Even in the context of medical triage the “complexity of disease and heterogeneous nature of general ICU patients, and our lack of quantitative knowledge of ICU outcomes” makes it almost impossible to “define enough specific conditions under which individual triage decisions should be made” (Joynt & Gomersall, 2005). How much more should we then be cognisant of the constraints of determining and applying the outcomes of bounded and subjective algorithms?

The moral principles, autonomy, beneficence, non-maleficence, and distributive justice (Beauchamp & Childress, 2001), provide useful pointers for considering the practice of

educational triage. It would, however, seem as if these principles do not transfer directly or easily to an educational context. Education is not a “causal technology” or a “process of ‘push and pull’”, but an “open and recursive system” (Biesta, 2007, p. 8) where the factors impacting on student retention and success are complex, and often interdependent and mutually constitutive (Subotzky & Prinsloo, 2011).

We would therefore propose an adaptation of the principles suggested by Beauchamp and Childress (2001) as follows.

1. Student and institutional autonomy as situated. Student success and retention are not the sole responsibility of either students or the institution, but a dynamic and often non-linear result of interdependent and mutually constitutive factors (Subotzky & Prinsloo, 2011). Both students’ and institutional autonomy should be acknowledged. The autonomy of both role-players is, however, bounded or situated in national and institutional policy frameworks and structures. Educational triage therefore finds itself in the nexus between respecting student autonomy but also, at the same time, ensuring the long-term sustainability of the institution. This raises the interesting dilemma whether students could refuse to attend compulsory support initiatives or alternative curricular pathways based on an assessment of their potential or past performances, and any other relevant data. Such a refusal concurs with the suggestions made by Joynt and Gomersall (2005) where patients are allowed to make autonomous and informed decisions declining to be admitted to ICU.

It is, however, important that the consequences of such a refusal be made clear to students, funders, and other stakeholders.

When additional resources are withheld from students based on analyses of their past performance, demographics, and findings from learning analytics, or when institutions exclude students from further registration opportunities, it is crucial to follow the procedural steps provided by Joynt and Gomersall (2005). The exclusion of students from further registration opportunities points to the possible limitations of directly transferring principles between triage in medical contexts to educational contexts. However, if institutions are transparent regarding the rationales, their diagnosis, prognosis, and outcomes, as well as providing evidence to support any decisions, the provision of or exclusion to services may be justified. We should, however, always be aware of the complexities of student success, the incompleteness of our algorithms and data as well as the short and long term implications of excluding students. This principle should be read concurrently with the next one dealing with beneficence.

2. The notion of beneficence requiring institutions to always act in the best interest of the student flows from the social contract between higher education and students (Slade & Prinsloo, 2014). Educational triage as moral practice is

primarily based on higher education's commitment to be student-centred and therefore consistent with not allowing students to continue on selected trajectories, if analyses clearly show that the continuation of the trajectory is neither in the interest of the student nor the institution. Providing access to higher education should never be providing access to failure (Meisenhelder, 2014). Educational triage as moral practice therefore should always be in the best interest of the student. This commitment presents an opportunity to practice the next principle, to do no harm.

3. The third principle indicates the need for non-maleficence. Based on the procedural proposal by Joynt and Gomersall (2005) that transparency should characterise not only the analysis but also the diagnosis, prognosis, and outcome, it is clear that the principles of non-maleficence and beneficence are two sides of the same coin. Analysing student data and deciding to exclude students from further educational opportunities or extra student support should always serve the principle of non-maleficence, however difficult and dramatic the short and long term implications.
4. The fourth principle of distributive justice poses a more difficult and interesting challenge for educational triage. Joynt and Gomersall (2005) state clearly that factors "such as ethnic origin, race, religion, sex, social status and ability to pay, and age should not be considered as acceptable criteria on which to base a triage decision" (p. 38). We agree that in a medical crisis situation, purely demographic factors should not play a role. On the other hand, we also acknowledge that access to resources, whether to affordable health care, social services, infrastructure, or security, is often (and increasingly so) based on a combination of historical privilege, initiatives to address past injustices, and socio-economic and ideological decision making. We simply cannot negate the impact of "causal power of social structures" (Elder-Vass, 2010).

Considering that education flows from and often maintains and perpetuates social and power structures, educational triage as moral practice cannot ignore the principle of distributive justice (Apple, 2004; Bauman, 2012; Bernstein, 1996; and Chomsky, 2013). We propose that there are issues of morality around not taking into account the historical impact of some of these factors in considering the classification of students in educational triage. It is immoral to simply take only educational performance into account where there is ample evidence of historical imbalances and injustices. Race, gender, culture, and various combinations of identity constructs should not be ignored in considering the scope and delimitation of groups of students who will be excluded, or receive no additional support. Morozov (2013b) warns that we don't know "what biases and discriminatory practices" are built in the algorithms we use (also see Boyd & Crawford, 2013). We acknowledge that the explicit mention of these criteria does make possibly for uncomfortable reading, but there is ample evidence that these constructs are currently used in the allocation of resources and, secondly, that they should be used. A case in point is current educational policy in the context of South Africa where

previous educational dispensations favored a racial criteria for admission into higher education (Baloyi, 2004; Chisholm, 2005; Dube, 1985; Jansen, 1990a, 1990b) and will impact for generations to come on student success and retention (Subotzky & Prinsloo, 2011). Within the UK, there are similar initiatives which target attention and resource toward particular groups. For example, the Higher Education Funding Council for England (HEFCE) provides specific funding to universities to support the costs of both recruiting and retaining students with particular demographic characteristics. These criteria have furthermore influenced educational policy throughout the history of higher education (Apple, 2004; Bernstein, 1977, 1996; Giroux, 1992, 2003) and we need to engage with these criteria and the contexts of their application on a theoretical level, however uncomfortable.

Having said that, the use of these identity constructs in the allocation of resources needs to be read in context with the other principles and not treated as a stand-alone issue. It is already difficult in educational contexts to ‘simply’ categorise students into students who don’t need assistance; students who, with additional support, may pass; and students who are destined to fail no matter any additional support. Marwick (2014) warns that data discrimination can lead to customers with the most potential being targeted and provided access to services while others will be classified as being of lower value and “waste” (par. 20). This is where educational triage (dramatically) differs from triage in medical contexts. There are a number of authors who express concern regarding some of the basic assumptions, epistemologies, and ontologies underlying the current hype in the discourses surrounding data-based decision making in education, especially with regard to teaching and learning (Clegg, 2005; Elliott, 2001; Knight et al., 2014; Oliver & Conole, 2003; Reeves, 2011; and Swain, 2013). Our conceptual and theoretical understandings of factors that impact on the effectiveness of teaching and learning are still incomplete and we should therefore tread carefully when we make decisions when resources are limited.

Against the backdrop of claims that “student data is the new oil” (Watters, 2013) that enables universities to be data-driven (Wishon & Rome, 2012), there are also concerns that learning analytics only values the measurable (Richardson, 2012), and that the “technocratic predictive logic” (Henman, 2004) inherent in the emphasis on students’ digital data forgets that students’ digital footprints do not represent the whole picture (see also Mayer-Schönberger, 2009). Biesta (2007, 2010) also expresses the concern that evidence of “what works” does not necessarily “work.”

## (In)conclusions

In this article we considered the complexities of “making moral decisions when resources are limited” (e.g., Joynt & Gomersall, 2005). The effective allocation of increasingly limited resources, although not new (e.g., Hartley, 1995), challenges higher education institutions to take concerns regarding student failure and dropout seriously.

Institutions increasingly rely on the analysis of data through algorithms to determine students' chances of success or risk of dropout and allocate resources according to a system of triage. Students are classified in different categories based on an assessment of their educational risk and the cost of increasing or ensuring their chances of success.

Though educational triage is germane to higher education within the discourses and practices of accountability, governmentality, and the optimisation of resources, there is a serious need to explore the epistemological and ontological assumptions underlying and informing these discourses and practices.

We have mapped educational triage against its historical development from the world of emergency medical care, exploring the principles and processes guiding triage. Though these principles and processes provide some insight into the complexities of triage, we found that the principles do not transfer seamlessly to educational contexts. Even within the discourses of medical triage there are concerns that diseases and emergency medical care are complex and we mostly lack sufficient knowledge to always be certain that we make the right decisions (Joynt & Gomersall, 2005). Biesta (2007, 2010) furthermore questions the epistemologies, ontologies, and practices underlying the direct transfer of practices in medical fields to education.

Despite these concerns, the principles and processes in medical triage allow us to explore the risks and potential of educational triage. We are able to understand the need to respect student autonomy in conjunction with the long-term sustainability of the institution. We can see the transferability of the concepts of beneficence and non-maleficence to an educational context. Further, we appreciate the complexity of the use of data and algorithms alone to drive student support. Learning analytics indeed offers the potential to provide targeted support based on what is known and it would be relatively simple to use learning analytics to justify an educational triage approach to determining student support. However, as we have shown, such an approach is simplistic and potentially immoral. It is hard to see a time when students may be fully defined by their personal data, nor be fully separated from their own social and historical contexts.

The principles and broad heuristic framework discussed in this article do not attempt to provide a detailed map or check list of bulleted points to guide us through the messiness of decisions that impact on students' chances of success, nor on the long-term sustainability of higher education institutions. We believe the article opens up the discourse and provokes further discussion regarding the question "how do we make moral decisions regarding students-at-risk and the allocation and effectiveness of resources, when resources are (increasingly) constrained?"

## Acknowledgements

An earlier version of this article was presented at the EDEN annual conference in Zagreb, 10-13 June, 2014.

We would like to acknowledge the care and input of the reviewers, as well as the financial support to one of the researchers by the South African National Research Foundation.

## References

- Altbach, P. G., Reisberg, L., & Rumbley, L. E. (2009). *Trends in global higher education: Tracking an academic revolution* (A report prepared for the UNESCO World Conference on Higher Education). Paris: UNESCO. Retrieved from [http://www.cep.edu.rs/public/Altbach\\_Reisberg\\_Rumbley\\_Tracking\\_an\\_Academic\\_Revolution\\_UNESCO\\_2009.pdf](http://www.cep.edu.rs/public/Altbach_Reisberg_Rumbley_Tracking_an_Academic_Revolution_UNESCO_2009.pdf)
- Apple, M. W. (2004). *Ideology and curriculum* (3rd edition). New York: Routledge Falmer.
- Arnold, K. (2010, March 3). Signals: Applying academic analytics. *EDUCAUSEreview*. Retrieved from <http://www.educause.edu/ero/article/signals-applying-academic-analytics>
- Baloyi, R. (2004). *The role of the state in the establishment of a culture of learning and teaching in South Africa (1910-2004)* (PhD thesis). University of South Africa, Pretoria.
- Barefoot, B. O. (2004). Higher education's revolving door: Confronting the problem of student dropout in US colleges and universities. *Open Learning*, 19–18. DOI: 10.1080/0268051042000177818
- Bauman, Z. (2012). *On education*. Cambridge, UK: Polity Press.
- Beauchamp T. L., & Childress J. F. (2001). *Principles of biomedical ethics* (5th ed). Oxford: Oxford University Press.
- Beer, C., Jones, D., & Clark, D. (2012). Analytics and complexity: Learning and leading for the future. Retrieved from [http://www.ascilite2012.org/images/custom/beer.colin\\_-\\_analytics\\_and.pdf](http://www.ascilite2012.org/images/custom/beer.colin_-_analytics_and.pdf)
- Bernstein, B. (1977). *Class, codes and control. Towards a theory of educational transmission* (Vol. 3, 2<sup>nd</sup> edition). London: Routledge & Kegan Paul.
- Bernstein, B. (1996). *Pedagogy, symbolic control and identity: Theory, research, critique*. London: Taylor & Francis.
- Bienkowski, M., Feng, M., & Means, B. (2012). *Enhancing teaching and learning through educational data mining and learning analytics. An issue brief*. Washington, D.C. : U.S. Department of Education, Centre for Technology in Learning. Retrieved from <https://www.ed.gov/edblogs/technology/files/2012/03/edm-la-brief.pdf>

- Biesta, G. (2007). Why “what works” won’t work: Evidence-based practice and the democratic deficit in educational research. *Educational Theory*, 57(1), 1–22. DOI: 10.1111/j.1741-5446.2006.00241.x.
- Biesta, G. (2010). Why ‘what works’ still won’t work: From evidence-based education to value-based education. *Studies in Philosophy of Education*, 29, 491–503. DOI 10.1007/s11217-010-9191-x.
- Booher-Jennings, J. (2005). Below the bubble: “Educational triage” and the Texas Accountability System. *American Educational Research Journal*, 43(2), 231–268.
- Booth, M. (2012, July 18). Learning analytics: The new black. *EDUCAUSEreview*. Retrieved from <http://www.educause.edu/ero/article/learning-analytics-new-black>
- boyd, d., & Crawford, K. (2013). Six provocations for big data. Retrieved from [http://papers.ssrn.com/sol3/papers.cfm?abstract\\_id=1926431](http://papers.ssrn.com/sol3/papers.cfm?abstract_id=1926431)
- Burgess, S., Propper, C., Slater, H. & Wilson, D. (2005). Who wins and who loses from school accountability? CMPO discussion paper 05/128.
- Campbell, J. P., DeBlois, P. B., Oblinger, D. G. (2007). Academic analytics: A new tool for a new era. *EDUCAUSEreview*. Retrieved from <http://www.educause.edu/ero/article/academic-analytics-new-tool-new-era>
- Carr, N. (2012). The crisis in higher education. *Technology Review*. Retrieved from <http://www.technologyreview.com/featuredstory/429376/the-crisis-in-higher-education/>
- Caulfield, M. (2013, September 26). *Why the Course Signals math does not add up* [Web log post]. Retrieved from <http://hapgood.us/2013/09/26/why-the-course-signals-math-does-not-add-up/>
- Chisholm, L. (2005). The politics of curriculum review and revision in South Africa in regional context. *Compare: A Journal of Comparative Education*, 35(1), 79–100.
- Chomsky, N. (2013). *Power systems*. London, UK: Penguin.
- Clegg, S. (2005). Evidence-based practice in educational research: a critical realist critique of systematic review. *British Journal of Sociology in Education*, 26, 415–428.
- Clow, D. (2012). *The learning analytics cycle: Closing the loop effectively*. Paper presented at the 2nd International Conference on Learning Analytics and



- Knowledge (LAK12). Retrieved from <http://dl.acm.org/citation.cfm?id=2330636>
- Clow, D. (2013a). An overview of learning analytics. *Teaching in Higher Education*, 18(6), 683–695. DOI: 10.1080/13562517.2013.827653
- Clow, D. (2013b, November 13). *Looking harder at Course Signals* [Web log post]. Retrieved from <http://douglow.org/2013/11/13/looking-harder-at-course-signals/>
- Clow, D. (2013c, December 10). *InFocus: Learning analytics and big data* [Web log post]. Retrieved from <http://douglow.org/2013/12/10/infocus-learner-analytics-and-big-data/>
- Cobbold, T. (2010, September 24). *Get used to “Bubble Kids” and “Educational Triage”* [Personal web log post]. Retrieved from <http://www.saveourschools.com.au/league-tables/get-used-to-bubble-kids-and-educational-triage>
- Crehan, L. (2012, August 30). *Educational triage* [web log post]. Retrieved from <http://www.edapt.org.uk/news/2012/08/blog-educational-triage>
- Danaher, J. (2014a, February 9). *What’s the case for sousveillance?* (Part one) [Web log post]. Retrieved from <http://philosophicaldisquisitions.blogspot.com/2014/02/whats-case-for-sousveillance-part-one.html>
- Diaz, V., & Brown, M. (2012). Learning analytics. A report on the ELI focus session. Retrieved from <http://net.educause.edu/ir/library/PDF/ELI3027.pdf>
- Dube, E. F. (1985). The relationship between racism and education in South Africa. *Harvard Educational Review*, 55(1), 86–100.
- Elder-Vass, D. (2010). *The causal power of social structures*. New York, NY: Cambridge University Press.
- Elliot, J. (2001). Making evidence-based practice educational. *British Educational Research Journal*, 27(5), 555–574.
- Essa, A. (2013). *Can we improve retention rates by giving students chocolates?* [Web log post]. Retrieved from <http://alfredessa.com/2013/10/can-we-improve-retention-rates-by-giving-students-chocolates/>
- Ferguson, R. (2012). The state of learning analytics in 2012: A review and future challenges. *Knowledge Media Institute*, Technical Report KMI-2012, 1. Retrieved from <http://kmi.open.ac.uk/publications/pdf/kmi-12-01.pdf>

- Forsythe, R. G., Chacon, F. J., Spicer, Z., & Valbuena, A. (2012). Two case studies of learner analytics in the university system of Maryland. *EDUCAUSEreview*. Retrieved from <http://www.educause.edu/ero/article/two-case-studies-learner-analytics-university-system-maryland>
- Gillborn, D., & Youdell, D. (2000). *Rationing education: Policy, practice, reform and equality*. Buckingham: Open University Press.
- Giroux, H. A. (1992). *Border crossings: Cultural workers and the politics of education*. New York: Routledge.
- Giroux, H. A. (2003). Racial injustice and disposable youth in the age of zero tolerance. *Qualitative Studies in Educatio*, 16(4), 553–565.
- Graber, K. C. (1996). Influencing student beliefs: The design of a “high impact” teacher education program. *Teaching and Teacher Education*, 12(5), 451–466.
- Grimes, S. K. (1997). Underprepared community college students: characteristics, persistence, and academic success. *Community College Journal of Research and Practice*, 21(1), 47–56. DOI: 10.1080/1066892970210105
- Hartley, D. (1995). The ‘McDonaldisation’ of higher education: Food for thought? *Oxford Review of Education*, 21(4), 409–423.
- Henman, P. (2004). Targeted! Population segmentation, electronic surveillance and governing the unemployed in Australia. *International Sociology*, 19, 173–191.
- Jansen, J. D. (1990a). Curriculum policy as compensatory legitimation? A view from the periphery. *Oxford Review of Education*, 16(1), 29–38.
- Jansen J.D. (1990b). Curriculum as political phenomenon: historical reflections on Black South African education. *The Journal of Negro Education*, 59(2), 195–206.
- Joynt, G. M., & Gomersall, C. D. (2005). Making moral decisions when resources are limited – an approach to triage in ICY patients with respiratory failure. *South African Journal of Critical Care (SAJCC)*, 21(1), 34–44. Retrieved from <http://www.ajol.info/index.php/sajcc/article/view/35543>
- Knight, S., Buckingham Shum, S., & Littleton, K. (2013). Collaborative sensemaking in learning analytics. Retrieved from <http://oro.open.ac.uk/36582/>
- Kogan, M. (1987). The political view. In Burton R. Clark, (Ed), *Perspectives on higher education: Eight disciplinary and comparative views* (pp. 56–78). Berkeley, CA: University of California Press.

- Lagowski, J. J. (1995). Higher education: A time for triage? *Journal of Chemical Education*, 72(10), 861.
- Manning, C. (2012, March 14). *Educational triage* [Web log post]. Retrieved from <http://colinmcit.blogspot.co.uk/2012/03/educational-triage.html>
- Marks, R. (2012), "I get the feeling that it is really unfair": Educational triage in primary mathematics. *Proceedings of the British Society for Research into Learning Mathematics* 32(2), Smith, C. (Ed.) Retrieved from <https://www.bsrlm.org.uk/IPs/ip32-2/BSRLM-IP-32-2-10.pdf>
- Marwick, A. E. (2014, January 9). How your data are being deeply mined [Web log post]. *The New York Review of Books*. Retrieved from <http://www.nybooks.com/articles/archives/2014/jan/09/how-your-data-are-being-deeply-mined/?pagination=false>
- May, H. (2011). Is all the fuss about learning analytics just hype? Retrieved from <http://www.loomlearning.com/2011/analytics-schmanalytics>
- Mayer-Schönberger, V. (2009). *Delete. The virtue of forgetting in the digital age*. Princeton, NJ: Princeton University Press.
- McInerney, D. M., King, R. B. (2013), Harnessing the power of motivational factors for optimizing the educational success of remote indigenous students: A cross-cultural study. In Rhonda G. Craven & Janet Mooney (Eds.), *Seeding success in indigenous Australian higher education* (Diversity in Higher Education, Volume 14) (pp.81–111). Emerald Group Publishing Limited. DOI: 10.1108/S1479-3644(2013)0000014004.
- Meisenhelder, S. (2014, March 6). *Rush to online higher ed only provides 'access' to failure* [Web log post]. Retrieved from [http://www.huffingtonpost.com/susan-meisenhelder/rush-to-online-higher-education\\_b\\_4914762.html](http://www.huffingtonpost.com/susan-meisenhelder/rush-to-online-higher-education_b_4914762.html)
- Morozov, E. (2013a, October 23). The real privacy problem. *MIT Technology Review*. Retrieved from <http://www.technologyreview.com/featuredstory/520426/the-real-privacy-problem/>
- Morozov, E. (2013b). *To save everything, click here*. London, UK: Penguin Books.
- Newman, F., Couturier, L., & Scurry, J. (2010). *The future of higher education: Rhetoric, reality, and the risks of the market*. San Francisco, CA: Jossey Bass.
- New Media Consortium. (2014). *NMC Horizon Report*. Retrieved from <http://www.nmc.org/pdf/2014-nmc-horizon-report-he-EN.pdf>

- Oblinger, D. G. (2012). Let's talk analytics. *EDUCAUSEreview* [online]. July/August, 10–13. Retrieved from <http://www.educause.edu/ero/article/lets-talk-analytics>
- Oliver, M., & Conole, G. (2003). Evidence-based practice and e-learning in higher education: Can we and should we? *Research Papers in Education*, 18(4), 385–397. DOI: 10.1080/0267152032000176873
- Pappano, L. (2012, November 12). The year of the MOOC [Web log post]. *New York Times*. Retrieved from <http://query.nytimes.com/gst/fullpage.html?res=9906E0D91F3EF937A35752C1A9649D8B63>
- Prinsloo, P. (2009). Modelling throughput at Unisa: The key to the successful implementation of ODL. Retrieved from <http://uir.unisa.ac.za/handle/10500/6035>
- Reeves, T. (2011). Can educational research be both rigorous and relevant? *Educational Designer. Journal of the International Society for Design and Development in Education*. Retrieved from <http://www.educationdesigner.org/ed/volume1/issue4/article13/index.htm>
- Richardson, W. (2012, July 14). *Valuing the immeasurable* [Web log post]. Retrieved from <http://willrichardson.com/post/27223512371/valuing-the-immeasurable>
- Rovai, A. P. (2002). In search of higher persistence rates in distance education online programs. *Internet and Higher Education*, 6, 1–16. DOI: 10.1016/S1096-7516(02)00158-6.
- Rust, V. D., & Kim, S. (2012). The global competition in higher education. *World Studies in Education*, 13(1), 2–50. Retrieved from [http://www.academia.edu/2490323/The\\_Global\\_Competition\\_in\\_Higher\\_Education](http://www.academia.edu/2490323/The_Global_Competition_in_Higher_Education)
- Selwyn, N. (2014). *Distrusting educational technology. Critical questions for changing times*. New York, NY: Routledge.
- Shirky, C. (2014, January 29). *The end of higher education's golden age* [Web log post]. Retrieved from <http://www.shirky.com/weblog/2014/01/there-isnt-enough-money-to-keep-educating-adults-the-way-were-doing-it/>
- Siemens, G. (2011). Learning analytics: A foundation for informed change in higher education. Retrieved from <http://www.educause.edu/library/resources/learning-analytics-foundation-informed-change-higher-education>

- Siemens, G., & Long, P. (2011). Penetrating the fog: Analytics in learning and education. *EDUCAUSE Review*, September/October, 31-40. Retrieved from <https://net.educause.edu/ir/library/pdf/ERM1151.pdf>
- Siemens, G. (2013). Learning analytics: The emergence of a discipline. *American Behavioural Scientist*, 57(10), 1380–1400.
- Slade, S., & Prinsloo, P. (2013). Learning analytics: Ethical issues and dilemmas. *American Behavioral Scientist*, 57(1) pp. 1509–1528.
- Slaughter, S., & Rhoades, G. (2010). *Academic capitalism and the new economy: Markets, state, and higher education*. Baltimore, Maryland: Johns Hopkins University Press.
- Sparks, S. D. (2012, March 9). *Study finds 'Bubble Student' triage a gut reaction to rising standards* [Personal web log post]. Retrieved from [http://blogs.edweek.org/edweek/inside-school-research/2012/03/study\\_finds\\_bubble\\_student\\_tri.html](http://blogs.edweek.org/edweek/inside-school-research/2012/03/study_finds_bubble_student_tri.html)
- Staley, D. J., & Trinkle, D. A. (2011). The changing landscape of higher education. *EDUCAUSEreview*. [Online]. Retrieved from <http://www.educause.edu/ero/article/changing-landscape-higher-education>
- Straumsheim, C. (2013, November 6). *Mixed signals* [Web log post]. Retrieved from <http://www.insidehighered.com/news/2013/11/06/researchers-cast-doubt-about-early-warning-systems-effect-retention>
- Subotzky, G., & Prinsloo, P.. (2011). Turning the tide: A socio-critical model and framework for improving student success in open distance learning at the University of South Africa. *Distance Education*, 32(2), 177–193.
- Swain, H. (2013, August 5). Are universities collecting too much information on staff and students? [Web log post]. *The Guardian*. Retrieved from <http://www.theguardian.com/education/2013/aug/05/electronic-data-trail-huddersfield-loughborough-university>
- The Economist. (2014, June 28<sup>th</sup>-July 4<sup>th</sup>). Creative destruction. Reinventing the university. *The Economist*, 411(8893).
- Van Barneveld, A., Arnold, K. E., & Campbell, J. P. (2012). Analytics in higher education: Establishing a common language. *EDUCAUSE Learning Initiative*, 1, 1–11. Retrieved from <http://sites.ewu.edu/elearningservices/files/2012/06/Analytics-in-Higher-Education-Establishing-a-Common-Language-ELI3026.pdf>

- Wagner, E., & Ice, P. (2012, July 18). Data changes everything: delivering on the promise of learning analytics in higher education. *EDUCAUSEreview*. Retrieved from <http://www.educause.edu/ero/article/data-changes-everything-delivering-promise-learning-analytics-higher-education>
- Watters, A. (2012). Unbundling and unmooring: technology and the higher ed tsunami. *EDUCAUSEreview*. Retrieved from <http://www.educause.edu/ero/article/unbundling-and-unmooring-technology-and-higher-ed-tsunami>
- Watters, A. (2013, October 13). *Student data is the new oil: MOOCs, metaphor, and money* [Web log post]. Retrieved from <http://www.hackeducation.com/2013/10/17/student-data-is-the-new-oil/>
- Waugh, W. L. Jnr. (1998). Conflicting values and cultures. The managerial threat to university governance. Retrieved from <http://www.jcu.edu/academic/planassess/planning/files/Planning%20articles/man managerial%20threat%20to%20univ%20govern.pdf>
- Wetterstrom, L. (2014, 28 January). The year after the MOOC. [Web log post]. *The Gate. Political analysis and opinion from the University of Chicago*. Retrieved from <http://uchicagogate.com/2014/01/28/years-after-mooc/>
- Wiley, D., & Hilton III, J. (2009). Openness, dynamic specialization, and the disaggregated future of higher education. *International Review of Research in Open and Distance Learning*, 10(5), 1–16. Retrieved from <http://www.irrodl.org/index.php/irrodl/article/view/768/1414>
- Wilson, T. (2012, March 30). *Educational triage – who gets lost?* [Personal web log post]. Retrieved from <http://nisce.org/educational-triage/>
- Winslow, G. R. (1982). *Triage and justice*. Berkeley, CA: University of California Press.
- Wishon, G. D., & Rome, J. (2012, 13 August). Enabling a data-driven university. *EDUCAUSEreview*. Retrieved from <http://www.educause.edu/ero/article/enabling-data-driven-university>
- World Medical Association. Statement on Medical Ethics in the Event of Disasters. (1994). Adopted by the 46th WMA General Assembly, Stockholm, Sweden, September and revised by the 57th WMA General Assembly, Pilanesberg, South Africa, October 2006. Retrieved from <http://www.wma.net/en/30publications/10policies/d7/>
- Yorke, M. (2004). Retention, persistence and success in on-campus higher education, and their enhancement in open and distance learning. *Open Learning: The*

*Journal of Open, Distance and e-Learning*, 19(1), 19–32. DOI:  
10.1080/0268051042000177827

Athabasca University 

